

TECHNICAL GUIDE FOR HOISTS

Dimensions (SI/50Hz)

SI

SUPDOCTGQDIM3-0.ORD 6.9.2013

- - - -

080674 10.10.2010

SWF Krantechnik GmbH

Postbox 310410
68264 Mannheim
Germany

Boehringer Straße 4
68307 Mannheim
Germany

tel +49(0)621 789-900
fax +49(0)621 789 90-100
Info@swfkrantechnik.com
www.swfkrantechnik.com

Table of contents

1	CHANGE HISTORY	6
	LOW HEADROOM TROLLEY	8
2	LOW HEADROOM HOIST NB, REEVING: 02.....	9
3	LOW HEADROOM HOIST NB, REEVING: 04.....	11
4	LOW HEADROOM HOIST NC, REEVING: 02	13
5	LOW HEADROOM HOIST NC, REEVING: 04	15
6	LOW HEADROOM HOIST NC, REEVING: 04, EXTENDED LOAD.....	17
7	LOW HEADROOM HOIST NC, REEVING: A2	19
8	LOW HEADROOM HOIST NC, REEVING: A4	21
9	LOW HEADROOM HOIST ND, REEVING: 02	23
10	LOW HEADROOM HOIST ND, REEVING: 04.....	25
11	LOW HEADROOM HOIST ND, REEVING: 04, EXTENDED LOAD	27
	DOUBLE GIRDER TROLLEY, MEDIUM	29
12	DOUBLE GIRDER HOIST NB, REEVING: 02.....	31
13	DOUBLE GIRDER HOIST NB, REEVING: 04.....	33
14	DOUBLE GIRDER HOIST NC, REEVING: 02.....	35
15	DOUBLE GIRDER HOIST NC, REEVING: 04.....	37
16	DOUBLE GIRDER HOIST ND, REEVING: 02.....	39
17	DOUBLE GIRDER HOIST ND, REEVING: 04.....	41
18	DOUBLE GIRDER HOIST ND, REEVING: 06.....	43
19	DOUBLE GIRDER HOIST ND, REEVING: 08.....	45
20	DOUBLE GIRDER HOIST ND, REEVING: 22.....	47
21	DOUBLE GIRDER HOIST ND, REEVING: 24.....	49
22	DOUBLE GIRDER HOIST ND, REEVING: 26.....	51
23	DOUBLE GIRDER HOIST ND, REEVING: 28.....	53
24	DOUBLE GIRDER HOIST NE, REEVING: 02.....	55
25	DOUBLE GIRDER HOIST NE, REEVING: 04.....	57
26	DOUBLE GIRDER HOIST NE, REEVING: 06.....	59
27	DOUBLE GIRDER HOIST NE, REEVING: 08.....	61
28	DOUBLE GIRDER HOIST NE, REEVING: 22.....	63
29	DOUBLE GIRDER HOIST NE, REEVING: 24.....	65
30	DOUBLE GIRDER HOIST NE, REEVING: 26.....	67
31	DOUBLE GIRDER HOIST NE, REEVING: 28.....	69
32	DOUBLE GIRDER HOIST NF, REEVING: 22	71
33	DOUBLE GIRDER HOIST NF, REEVING: 24	73
34	DOUBLE GIRDER HOIST NF, REEVING: 26	75
35	DOUBLE GIRDER HOIST NF, REEVING: 28.....	77
	DOUBLE GIRDER TROLLEY, HIGH.....	79
36	HIGH DOUBLE GIRDER HOIST NB, REEVING: 02.....	81
37	HIGH DOUBLE GIRDER HOIST NB, REEVING: 04.....	83

38	HIGH DOUBLE GIRDER HOIST NC, REEVING: 02	85
39	HIGH DOUBLE GIRDER HOIST NC, REEVING: 04	87
40	HIGH DOUBLE GIRDER HOIST ND, REEVING: 02	89
41	HIGH DOUBLE GIRDER HOIST ND, REEVING: 04	91
42	HIGH DOUBLE GIRDER HOIST ND, REEVING: 06	93
43	HIGH DOUBLE GIRDER HOIST ND, REEVING: 08	95
44	HIGH DOUBLE GIRDER HOIST ND, REEVING: 22	97
45	HIGH DOUBLE GIRDER HOIST ND, REEVING: 24	99
46	HIGH DOUBLE GIRDER HOIST ND, REEVING: 26	101
47	HIGH DOUBLE GIRDER HOIST ND, REEVING: 28	103
	DOUBLE GIRDER TROLLEY, LOW	105
48	LOW DOUBLE GIRDER HOIST ND, REEVING: 02	107
49	LOW DOUBLE GIRDER HOIST ND, REEVING: 04	109
	NORMAL HEADROOM TROLLEY	111
50	NORMAL HEADROOM HOIST NB, REEVING: 02	113
51	NORMAL HEADROOM HOIST NB, REEVING: 04	115
52	NORMAL HEADROOM HOIST NC, REEVING: 02	117
53	NORMAL HEADROOM HOIST NC, REEVING: 02, CURVED TRACK	119
54	NORMAL HEADROOM HOIST NC, REEVING: 04	121
55	NORMAL HEADROOM HOIST NC, REEVING: 04, CURVED TRACK	123
56	NORMAL HEADROOM HOIST ND, REEVING: 02	125
57	NORMAL HEADROOM HOIST ND, REEVING: 02, CURVED TRACK	127
58	NORMAL HEADROOM HOIST ND, REEVING: 04	129
59	NORMAL HEADROOM HOIST ND, REEVING: 04, CURVED TRACK	131
60	NORMAL HEADROOM HOIST ND, REEVING: 06	133
61	NORMAL HEADROOM HOIST ND, REEVING: 06, CURVED TRACK	135
62	NORMAL HEADROOM HOIST ND, REEVING: 08	137
63	NORMAL HEADROOM HOIST ND, REEVING: 08, CURVED TRACK	139
64	NORMAL HEADROOM HOIST ND, REEVING: 22	141
65	NORMAL HEADROOM HOIST ND, REEVING: 22, CURVED TRACK	143
66	NORMAL HEADROOM HOIST ND, REEVING: 24	145
67	NORMAL HEADROOM HOIST ND, REEVING: 24, CURVED TRACK	147
68	NORMAL HEADROOM HOIST ND, REEVING: 26	149
69	NORMAL HEADROOM HOIST ND, REEVING: 26, CURVED TRACK	151
70	NORMAL HEADROOM HOIST ND, REEVING: 28	153
71	NORMAL HEADROOM HOIST ND, REEVING: 28, CURVED TRACK	155
72	NORMAL HEADROOM HOIST NE, REEVING: 02	157
73	NORMAL HEADROOM HOIST NE, REEVING: 04	159
74	NORMAL HEADROOM HOIST NE, REEVING: 06	161
75	NORMAL HEADROOM HOIST NE, REEVING: 22	163
76	NORMAL HEADROOM HOIST NE, REEVING: 24	165
77	NORMAL HEADROOM HOIST NE, REEVING: 26	167
78	NORMAL HEADROOM HOIST NE, REEVING: 28	169
	FIXED HOIST	171
79	FIXED HOIST NB, REEVING: 02	173

80	FIXED HOIST NB, REEVING: 04.....	175
81	FIXED HOIST NC, REEVING: 02.....	177
82	FIXED HOIST NC, REEVING: 04.....	179
83	FIXED HOIST ND, REEVING: 02.....	181
84	FIXED HOIST ND, REEVING: 04.....	183
85	FIXED HOIST ND, REEVING: 06.....	185
86	FIXED HOIST ND, REEVING: 08.....	187
87	FIXED HOIST ND, REEVING: 22.....	189
88	FIXED HOIST ND, REEVING: 24.....	191
89	FIXED HOIST ND, REEVING: 26.....	193
90	FIXED HOIST ND, REEVING: 28.....	195
91	FIXED HOIST NE, REEVING: 02.....	197
92	FIXED HOIST NE, REEVING: 04.....	199
93	FIXED HOIST NE, REEVING: 06.....	201
94	FIXED HOIST NE, REEVING: 08.....	203
95	FIXED HOIST NE, REEVING: 22.....	205
96	FIXED HOIST NE, REEVING: 24.....	207
97	FIXED HOIST NE, REEVING: 26.....	209
98	FIXED HOIST NE, REEVING: 28.....	211
99	FIXED HOIST NF, REEVING: 22.....	213
100	FIXED HOIST NF, REEVING: 24.....	215
101	FIXED HOIST NF, REEVING: 26.....	217
102	FIXED HOIST NF, REEVING: 28.....	219
	MACHINERY HOIST.....	221
103	MACHINERY HOIST NBM1V, REEVING: M1.....	223
104	MACHINERY HOIST NBM2V, REEVING: M2, ROPES TO SAME DIRECTION.....	225
105	MACHINERY HOIST NBM2V, REEVING: M2, ROPES TO OPPOSITE DIRECTIONS.....	227
106	MACHINERY HOIST NCM1V, REEVING: M1.....	229
107	MACHINERY HOIST NCM2V, REEVING: M2, ROPES TO SAME DIRECTION.....	231
108	MACHINERY HOIST NCM2V, REEVING: M2, ROPES TO OPPOSITE DIRECTIONS.....	233
109	MACHINERY HOIST NDM1V, REEVING: M1.....	235
110	MACHINERY HOIST NDM2V, REEVING: M2, ROPES TO SAME DIRECTION.....	237
111	MACHINERY HOIST NDM2V, REEVING: M2, ROPES TO OPPOSITE DIRECTIONS.....	239
112	MACHINERY HOIST NEM1V, REEVING: M1.....	241
113	MACHINERY HOIST NEM2V, REEVING: M2.....	243
114	SOLO ELECTRICS IN EXTERNAL CUBICLE, NB/NC/ND LOW HEADROOM AND NORMAL HEADROOM HOISTS.....	245
115	HOOK OPERATED ULTIMATE HOISTING LIMIT.....	247
116	DOUBLE GIRDER TROLLEY OPTIONAL FEATURES.....	249
117	SERVICE PLATFORM: DOUBLE GIRDER TROLLEY, MEDIUM.....	251
118	HOOK.....	253
118.1	Standard Hook Block Dimensions.....	253
118.2	Optional Lockable Hook Block Dimensions.....	254
118.3	Optional Isolated Hook Block Dimensions.....	255
118.4	Single Hook Forging Dimensions.....	256
118.5	Ramshorn Hook Forging Dimensions.....	257
119	DRUM AND ROPE SHEAVE DIAMETERS.....	258

1 CHANGE HISTORY

Change	Drawing code	Table code	Modified by	Date
Hook orientation corrected.	D007219-A		ETTPSU	1.2.2013
H3 and H3* corrected.		062190	ETTPSU	19.2.2013
Dimensions PL1, PL2 and weights updated (NE/NF)		135661	ETTPSU	20.2.2013
Buffer extension lengths update; travelling motor side (NE/NF)		135661	ETTPSU	12.3.2013
Two Hoist Trolley removed from manual.	D004568-A	063932	ETTPSU	12.3.2013
Two Hoist Trolley removed from manual.	D004558-A	063934	ETTPSU	12.3.2013
Two Hoist Trolley removed from manual.	D004578-A	063871	ETTPSU	12.3.2013
Two Hoist Trolley removed from manual.	D004577-A	063870	ETTPSU	12.3.2013
Two Hoist Trolley removed from manual.	D004576-A	063869	ETTPSU	12.3.2013
Two Hoist Trolley removed from manual.	D004575-A	063868	ETTPSU	12.3.2013
Two Hoist Trolley removed from manual.	D004580-A	063873	ETTPSU	12.3.2013
Two Hoist Trolley removed from manual.	D004579-A	063872	ETTPSU	12.3.2013
Two Hoist Trolley removed from manual.	D004571-A	063877	ETTPSU	12.3.2013
Two Hoist Trolley removed from manual.	D004572-A	063878	ETTPSU	12.3.2013
Two Hoist Trolley removed from manual.	D004570-A	063876	ETTPSU	12.3.2013
Two Hoist Trolley removed from manual.	D004556-A	063874	ETTPSU	12.3.2013
Two Hoist Trolley removed from manual.	D004574-A	063879	ETTPSU	12.3.2013
Two Hoist Trolley removed from manual.	D004573-A	064086	ETTPSU	12.3.2013
Two Hoist Trolley removed from manual.	D004564-A	063875	ETTPSU	12.3.2013
Dimensions E1 and BF updated (length codes K-N)		101302	ETTPSU	21.5.2013
Dimensions E1 and BF updated (length codes K-N)		101303	ETTPSU	21.5.2013
Dimensions E1 and BF updated (length codes K-N)		101304	ETTPSU	21.5.2013
Dimensions E1 and BF updated (length codes K-N)		101305	ETTPSU	21.5.2013
Dimension R updated (length codes K-N)		102577	ETTPSU	21.5.2013
Dimension R updated (length codes K-N)		102578	ETTPSU	21.5.2013
Dimension R updated (length codes K-N)		102579	ETTPSU	21.5.2013
Dimension R updated (length codes K-N)		102580	ETTPSU	21.5.2013
Dimension W max. updated.		090659	ETTPSU	22.5.2013
Dimension W max. updated.		090660	ETTPSU	22.5.2013
Notes about PU wheels removed; PU wheels not available		135661	ETTPSU	22.5.2013
Added data about hoists with solo electric provisions.	D007500-A	157545	ETTPSU	22.5.2013
Added data about hook operated ultimate hoisting limit.		157665	ETTPSU	23.5.2013
Added data about double girder trolley options.	D007501-A	157729	ETTPSU	24.5.2013
Added data about ramshorn hook forgings.		102134	ETTPSU	28.5.2013
Added data about optional hooks.		102134	ETTPSU	30.5.2013
RSN20/25 replaced by RFN20/25.		102134	ETTPSU	30.5.2013
C-dimensions changed.		059568	ETTPSU	2.8.2013
C-dimensions changed.		004991	ETTPSU	2.8.2013
C-dimensions changed.		005000	ETTPSU	2.8.2013
C-dimensions changed.		062531	ETTPSU	2.8.2013
C-dimensions changed.		062529	ETTPSU	2.8.2013
C-dimension increases changed.		157665	ETTPSU	2.8.2013

--	--	--	--	--

LOW HEADROOM TROLLEY

2 LOW HEADROOM HOIST NB, REEVING: 02

Hoist dimensions

HOL m	Length code	M1 mm	H2 mm	H3 mm	H3* mm	BUF mm	Weight kg
12	A	326	90	495	510	368	175
19	C	456	144	495	510	498	195

Motor dimensions

Motor	P1	P2	P3	A3	S3
MOT (mm)	386	446	476	446	526
Weight (kg)	21	31	35	32	28

Trolley dimensions

B min.	B max.	ØWD	ØBU	BU	BUH	E1	E2	GEA	H1	H4	TD
80	410	80	40	42	28	100	532	110	132	524	153
TF	TH	TW									
32	248	29									

D002075_A
061739

C-dimensions

B	C
80 - 270	400
271 - 320	430
321 - 370	460
371 - 410	485

Note: All dimensions in mm.

Note: Weight calculated with P1 motor.

* Please, disregard the dimension H3*.

Low Headroom Hoist NB, REEVING: 02

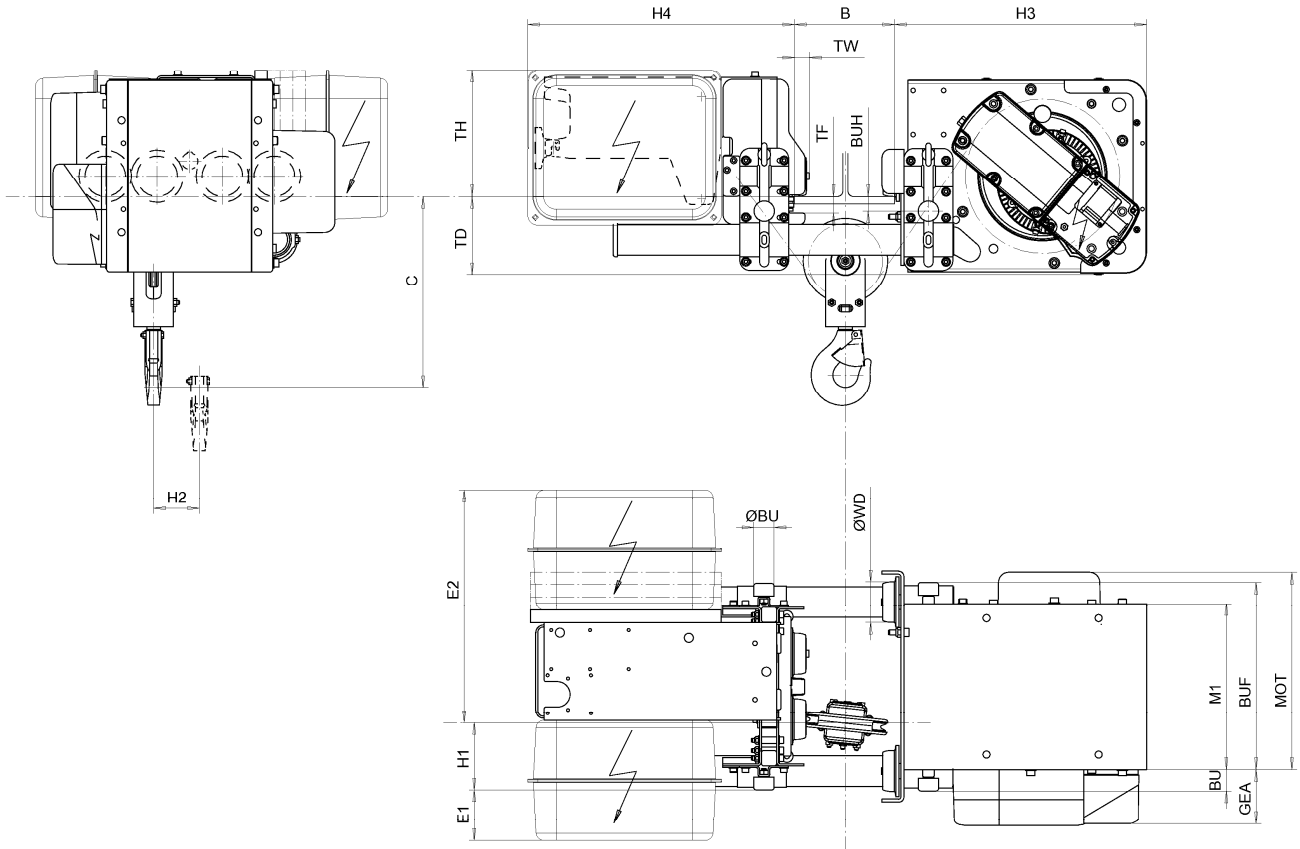

D002075-A

3 LOW HEADROOM HOIST NB, REEVING: 04

Hoist dimensions

HOL m	Length code	M1 mm	H2 mm	H3 mm	H3* mm	BUF mm	Weight kg
6	A	326	45	495	510	368	180
9.5	C	456	72	495	510	498	200

Motor dimensions

Motor	P1	P2	P3	A3	S3
MOT (mm)	386	446	476	446	526
Weight (kg)	21	31	35	32	28

Trolley dimensions

B min.	B max.	ØWD	ØBU	BU	BUH	E1	E2	GEA	H1	H4	TD
80	410	80	40	42	28	100	461	110	203	524	153
TF	TH	TW									
32	248	29									

D002080_A
062124

C-dimensions

B	C
80 - 270	350
271 - 320	380
321 - 370	410
371 - 410	435

Note: All dimensions in mm.

Note: Weight calculated with P1 motor.

* Please, disregard the dimension H3*.

Low Headroom Hoist NB, REEVING: 04

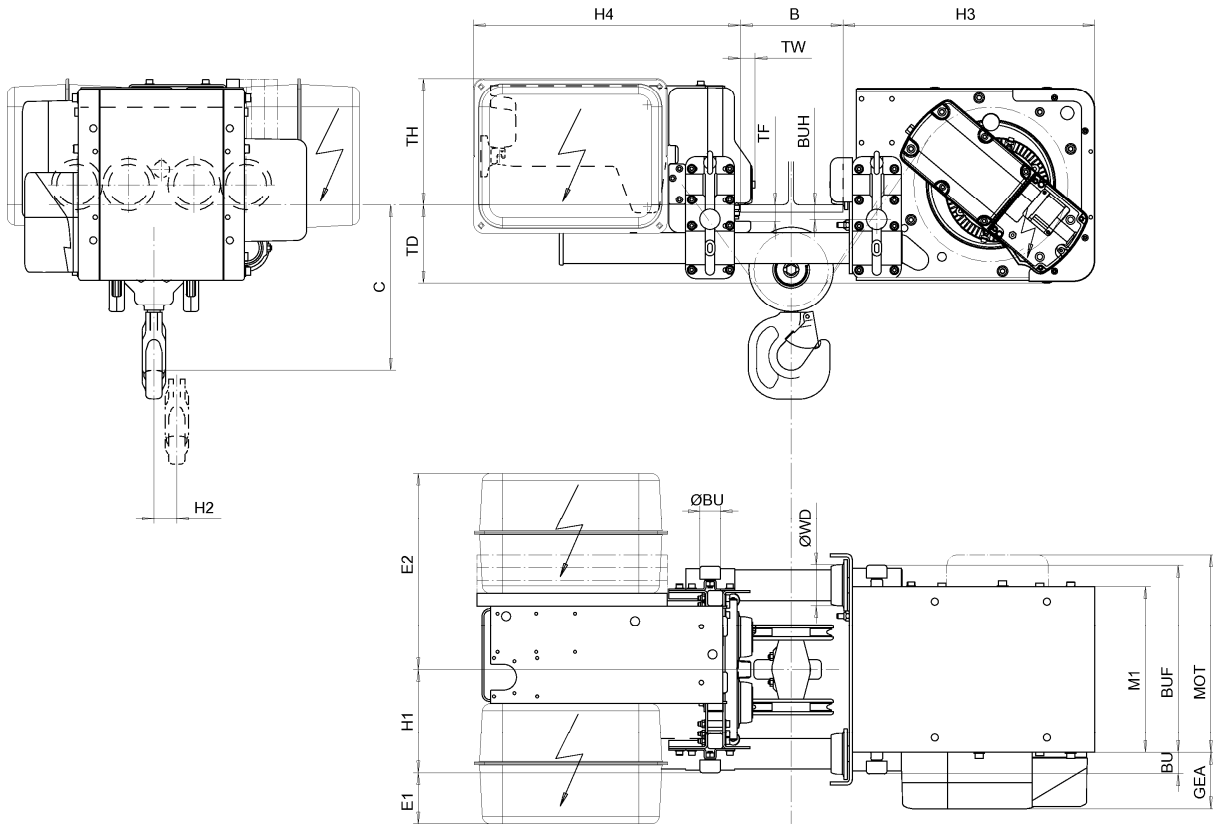

D002080-A

4 LOW HEADROOM HOIST NC, REEVING: 02

Hoist dimensions

HOL m	Length code	M1 mm	H2 mm	H3 mm	H3* mm	BUF mm	Weight kg
12	B	356	95	568	584	524	325
18	C	456	144	568	584	624	345
24	D	556	193	568	584	724	365

Motor dimensions

Motor	P3	P4	A3	S3	S5
MOT (mm)	473	574	443	523	602
Weight (kg)	35	53	32	28	53

Trolley dimensions

B min.	B max.	ØWD	ØBU	BU	BUH	E1	E2	GEA	H1	H4	TD
100	490	100	63	168	42	8	628	116	258	536	203
TF	TH	TW									
45	241	38									

D002087_A
001576

C-dimensions

B	C
100 - 250	440
251 - 300	470
301 - 350	505
351 - 400	535
401 - 450	570
451 - 490	595

Note: All dimensions in mm.

Note: Weight calculated with P3 motor.

Note: Motor S5 is unavailable for load class 3200 kg.

* Please, disregard the dimension H3*.

Low Headroom Hoist NC, REEVING: 02

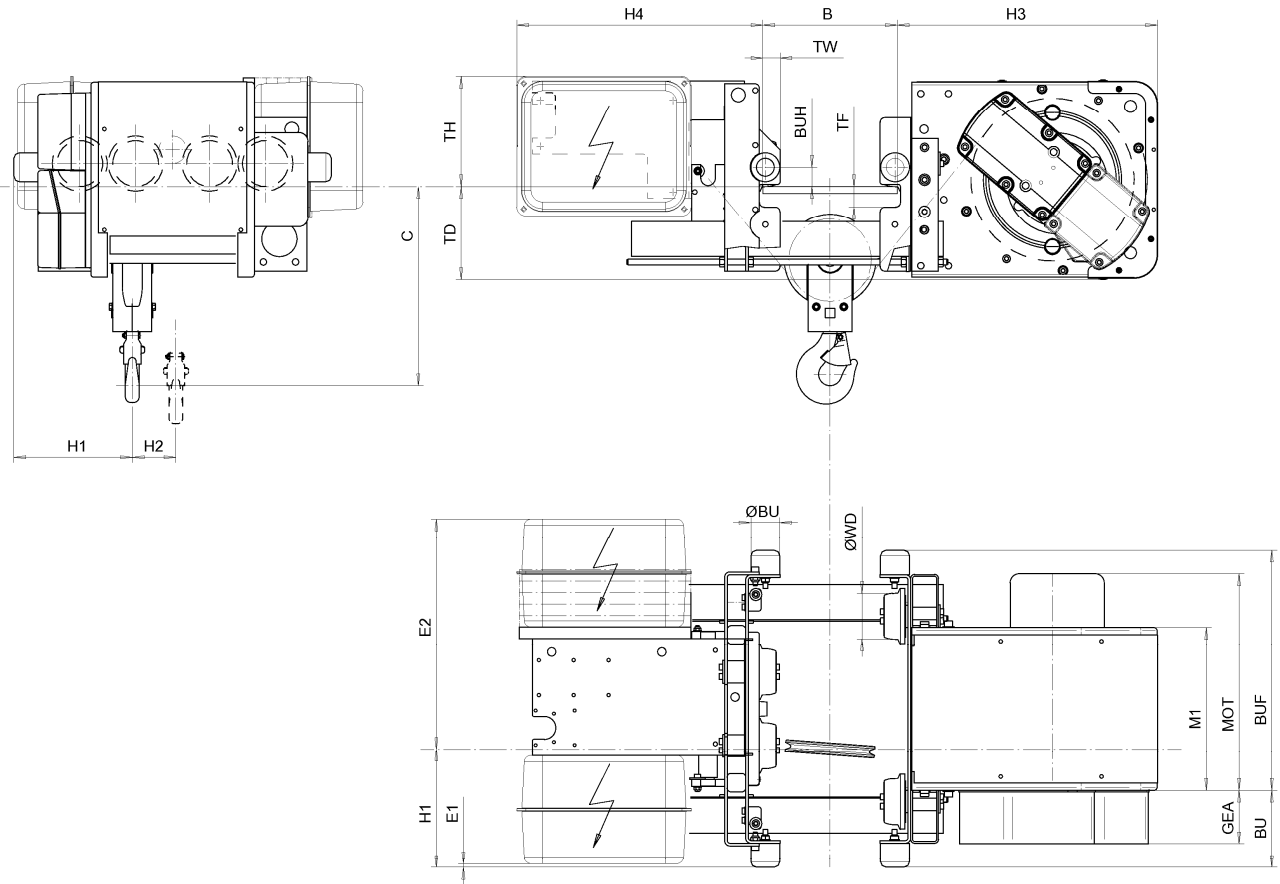

D002087-A

5 LOW HEADROOM HOIST NC, REEVING: 04

Hoist dimensions

HOL m	Length code	M1 mm	H2 mm	H3 mm	H3* mm	BUF mm	Weight kg
6	B	356	49	568	584	524	330
9	C	456	74	568	584	624	350
12	D	556	99	568	584	724	370

Motor dimensions

Motor	P3	P4	A3	S3	S5
MOT (mm)	473	574	443	523	602
Weight (kg)	35	53	32	28	53

Trolley dimensions

B min.	B max.	ØWD	ØBU	BU	BUH	E1	E2	GEA	H1	H4	TD
100	490	100	63	168	42	8	548	116	338	536	203
TF	TH	TW									
45	241	38									

D002092_A
062166

C-dimensions

B	C
100 - 199	490
200 - 249	460
250 - 300	425
301 - 350	455
351 - 400	490
401 - 450	520
451 - 490	550

Note: All dimensions in mm.

Note: Weight calculated with P3 motor.

* Please, disregard the dimension H3*.

Low Headroom Hoist NC, REEVING: 04

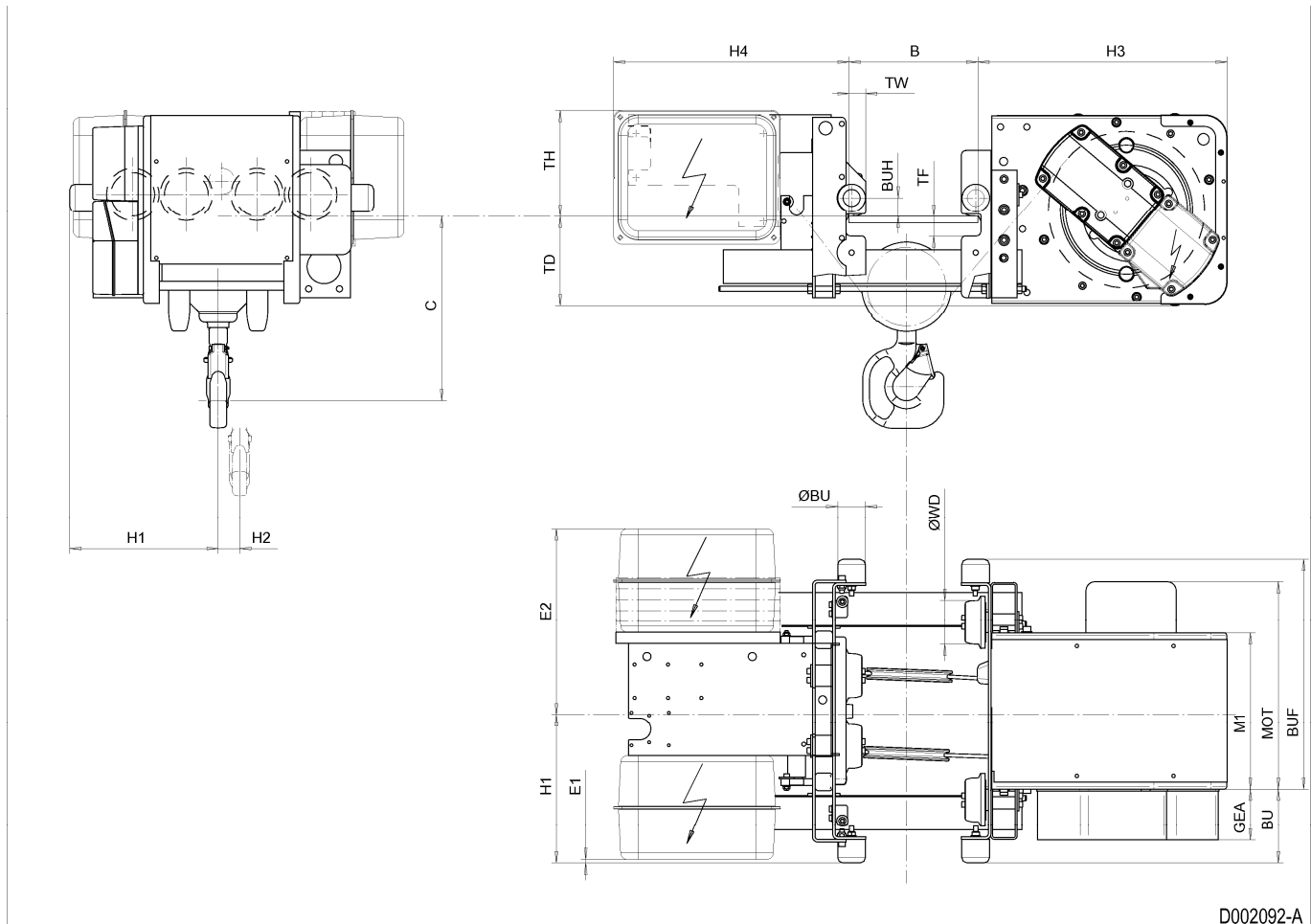

D002092-A

6 LOW HEADROOM HOIST NC, REEVING: 04, EXTENDED LOAD

Hoist dimensions

HOL m	Length code	M1 mm	H2 mm	H3 mm	H3* mm	BUF mm	Weight kg
6	B	356	49	574	590	524	330
9	C	456	74	574	590	624	350
12	D	556	99	574	590	724	370

Motor dimensions

Motor	P3	A3	S3
MOT (mm)	473	443	523
Weight (kg)	35	32	28

Trolley dimensions

B min.	B max.	ØWD	ØBU	BU	BUH	E1	E2	GEA	H1	H4	TD
100	490	125	63	195	41	56	568	116	366	538	190
TF	TH	TW									
42	253	42									

D002093_A
062511

C-dimensions

B	C
100 - 199	505
200 - 249	470
250 - 300	440
301 - 350	475
351 - 400	505
401 - 450	540
451 - 490	570

Note: All dimensions in mm.

Note: Weight calculated with P3 motor.

* Please, disregard the dimension H3*.

Low Headroom Hoist NC, REEVING: 04, Extended Load

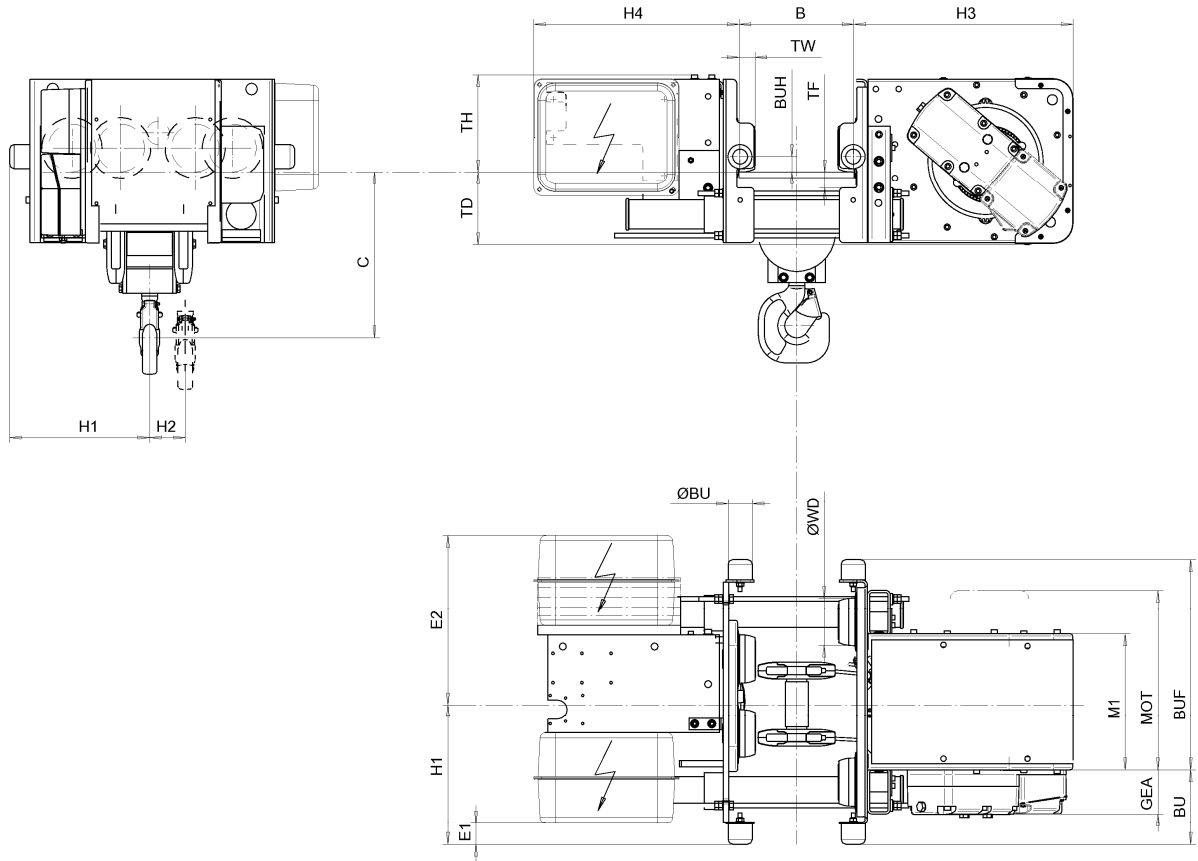

D002093-A

7 LOW HEADROOM HOIST NC, REEVING: A2

Hoist dimensions

HOL m	Length code	M1 mm	H2 mm	H3 mm	H3* mm	BUF mm	Weight kg
22.5	C	456	144	568	584	624	320
30	D	556	193	568	584	724	340

Motor dimensions

Motor	P2	P4	A3	S3	S5
MOT (mm)	446	574	443	523	602
Weight (kg)	35	53	32	28	53

Trolley dimensions

B min.	B max	ØWD	ØBU	BU	BUH	E1	E2	GEA	H1	H4	TD
100	490	100	63	168	42	8	628	116	258	536	203
TF	TH	TW									
45	241	38									

D002106_A
062531

C-dimensions

B	C
100 - 300	450
301 - 350	475
351 - 400	505
401 - 450	540
451 - 490	570

Note: All dimensions in mm.

Note: Weight calculated with P2 motor.

* Please, disregard the dimension H3*.

Low Headroom Hoist NC, REEVING: A2

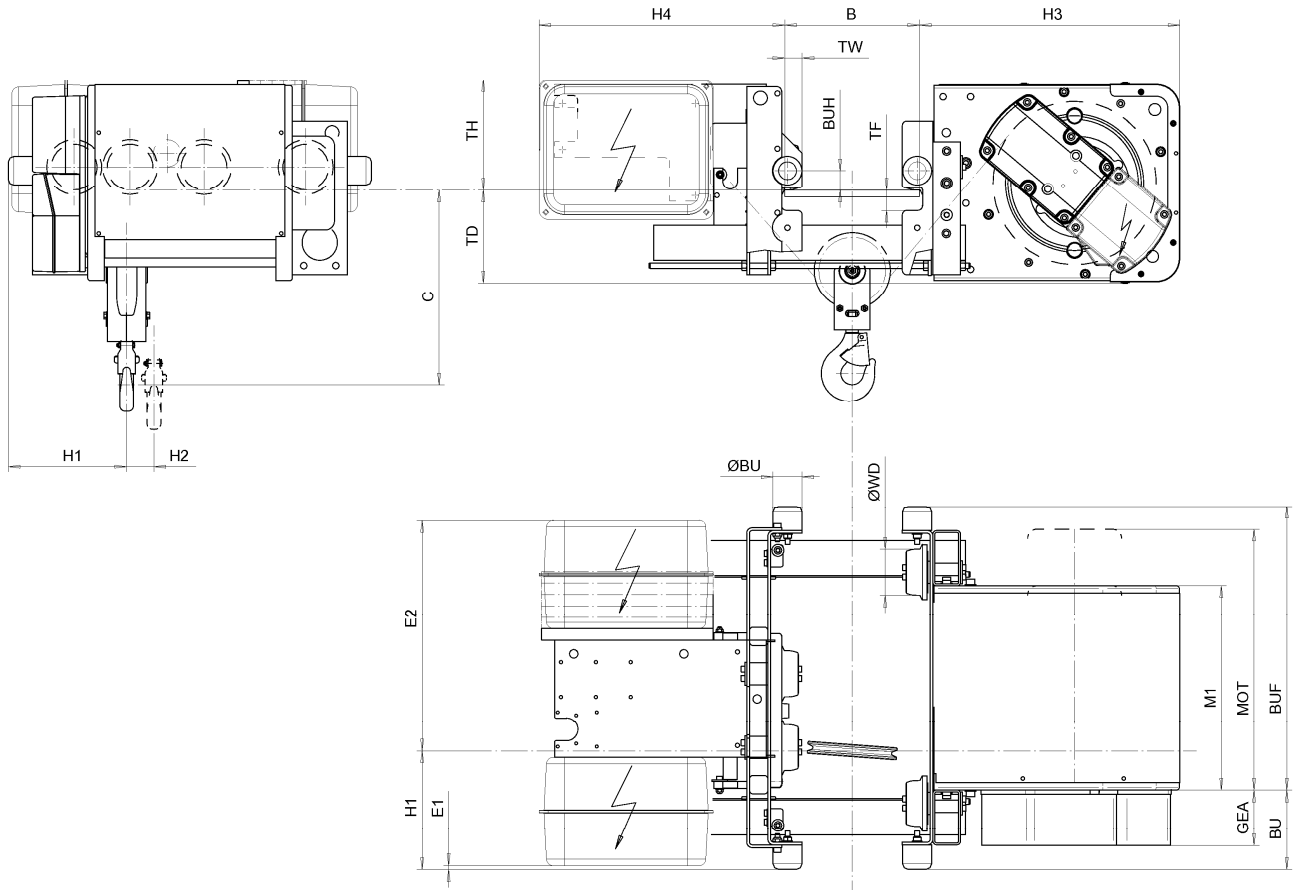

D002106-A

8 LOW HEADROOM HOIST NC, REEVING: A4

Hoist dimensions

HOL m	Length code	M1 mm	H2 mm	H3 mm	H3* mm	BUF mm	Weight kg
11	C	456	73	568	584	624	335
15	D	556	99	568	584	724	355

Motor dimensions

Motor	P2	P4	A3	S3	S5
MOT (mm)	446	574	443	523	602
Weight (kg)	35	53	32	28	53

Trolley dimensions

B min.	B max.	ØWD	ØBU	BU	BUH	E1	E2	GEA	H1	H4	TD
100	490	100	63	168	42	8	568	116	318	536	203
TF	TH	TW									
45	241	38									

D002107_A
062529

C-dimensions

B	C
100 - 300	380
301 - 350	415
351 - 400	445
401 - 450	480
451 - 490	510

Note: All dimensions in mm.

Note: Weight calculated with P2 motor.

* Please, disregard the dimension H3*.

Low Headroom Hoist NC, REEVING: A4

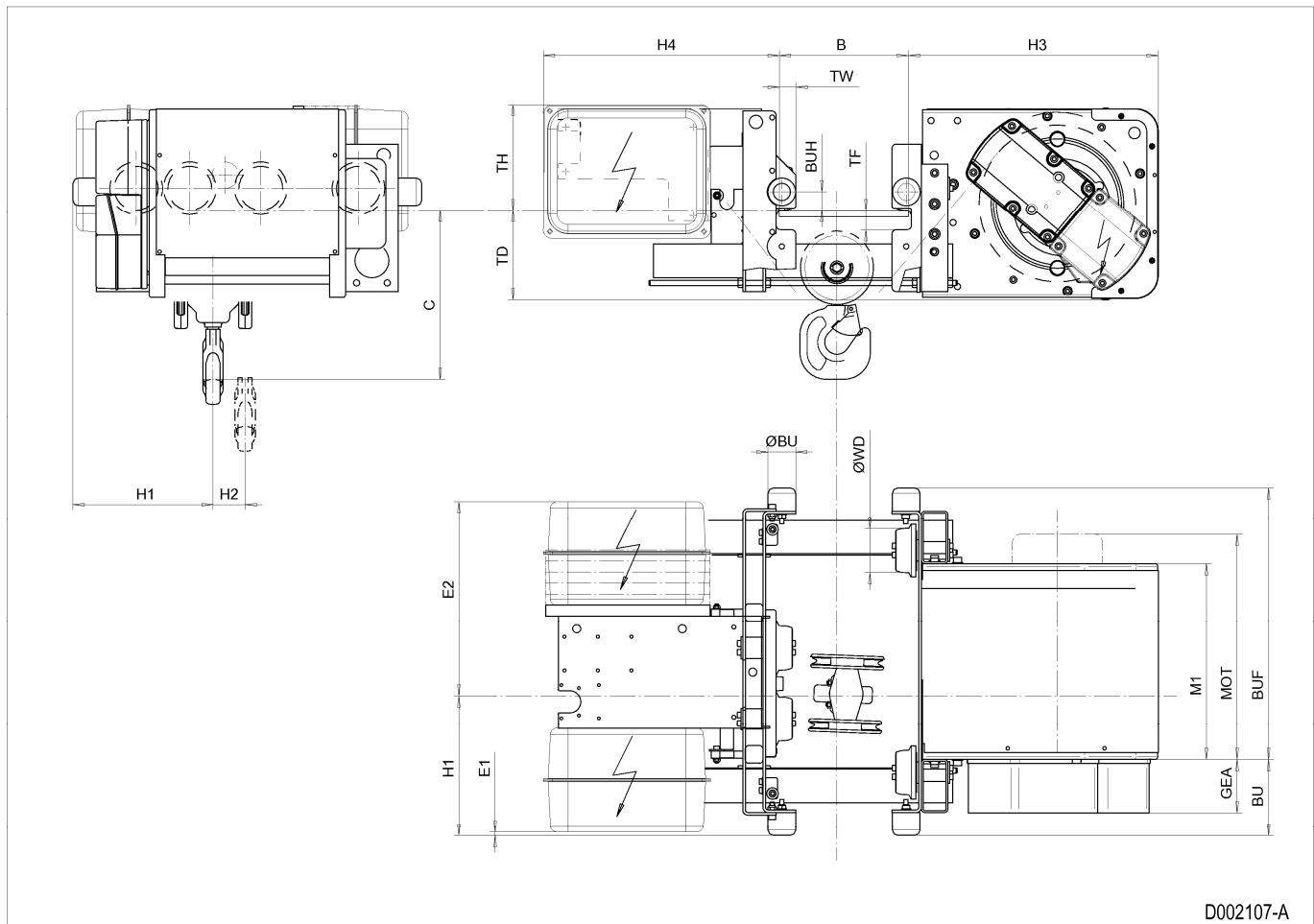

D002107-A

9 LOW HEADROOM HOIST ND, REEVING: 02

Hoist dimensions

HOL m	Length code	M1 mm	H2 mm	H3 mm	H3* mm	BUF mm	Weight kg
18	D	558	176	667	687	809	595
24	E	678	235	667	687	929	640
32	F	828	309	667	687	1079	690

Motor dimensions

Motor	P5	P6	P7	A5	S5	S7
MOT (mm)	578	578	618	498	606	757
Weight (kg)	58	85	105	45	53	81

Trolley dimensions

B min.	B max.	ØWD	ØBU	BU	BUH	GEA	H1	H4	TD	TF	TH
100	610	125	63	250	35	143	411	618	256	60	266
TW											
42											

D002112_A

059568

C-dimensions

B	C
100 - 199	700
200 - 259	660
260 - 439	660
440 - 540	640
541 - 610	680

Note: All dimensions in mm.

Note: Weight calculated with P5 motor.

Note: Motor S7 is unavailable for load class 6300 kg.

* Please, disregard the dimension H3*.

Low Headroom Hoist ND, REEVING: 02

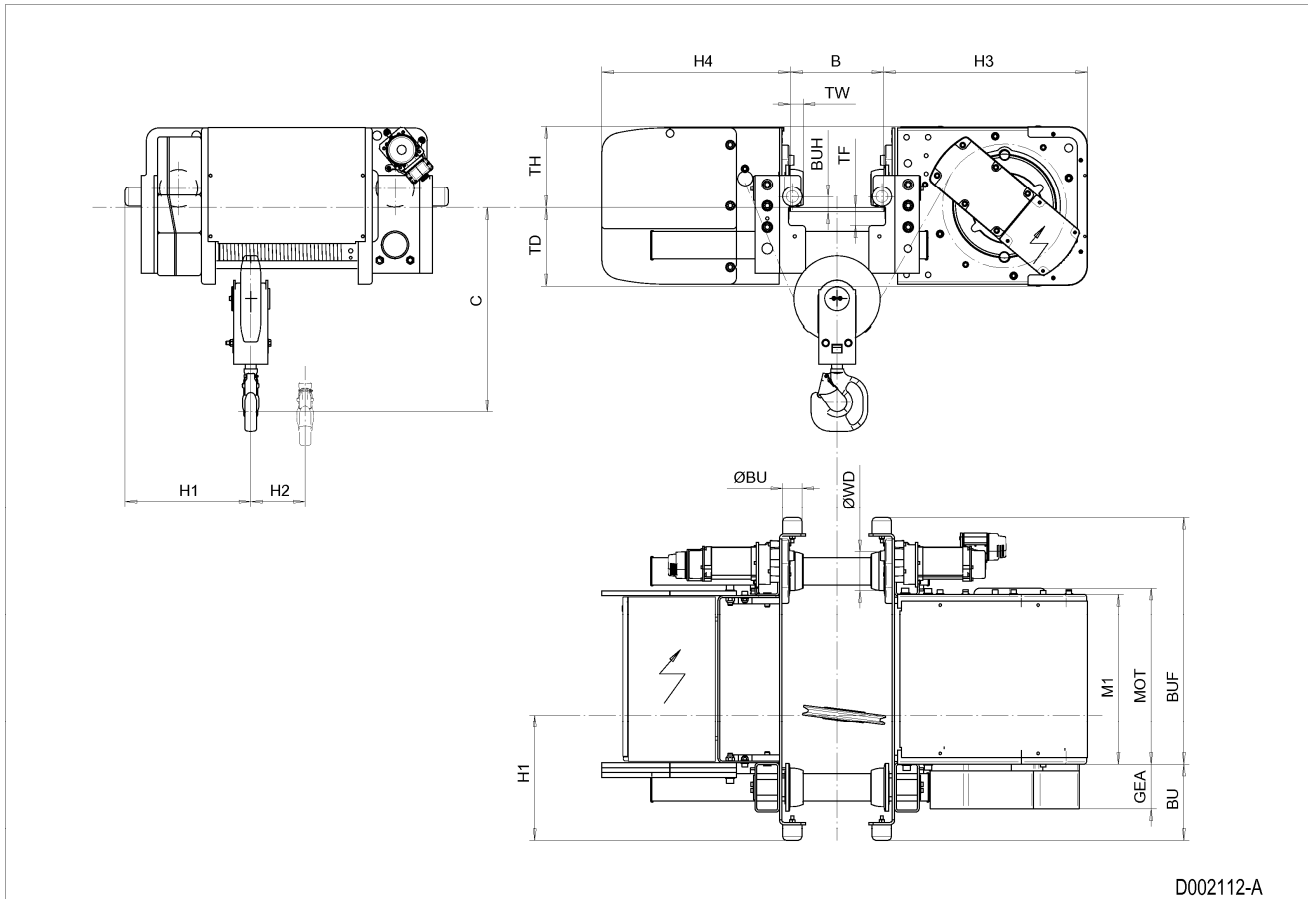

10 LOW HEADROOM HOIST ND, REEVING: 04

Hoist dimensions

HOL m	Length code	M1 mm	H2 mm	H3 mm	H3* mm	BUF mm	Weight kg
9	D	558	88	667	687	809	610
12	E	678	118	667	687	929	660
16	F	828	156	667	687	1079	710

Motor dimensions

Motor	P5	P6	P7	A5	S5	S7
MOT (mm)	578	578	618	498	606	757
Weight (kg)	58	85	105	45	53	81

Trolley dimensions

B min.	B max.	ØWD	ØBU	BU	BUH	GEA	H1	H4	TD	TF	TH
100	610	125	63	250	35	143	489	618	256	60	266
TW											
42											

D002117_A

004991

C-dimensions

B	C
100 - 199	660
200 - 289	630
290 - 530	600
531 - 610	650

Note: All dimensions in mm.

Note: Weight calculated with P5 motor.

* Please, disregard the dimension H3*.

Low Headroom Hoist ND, REEVING: 04

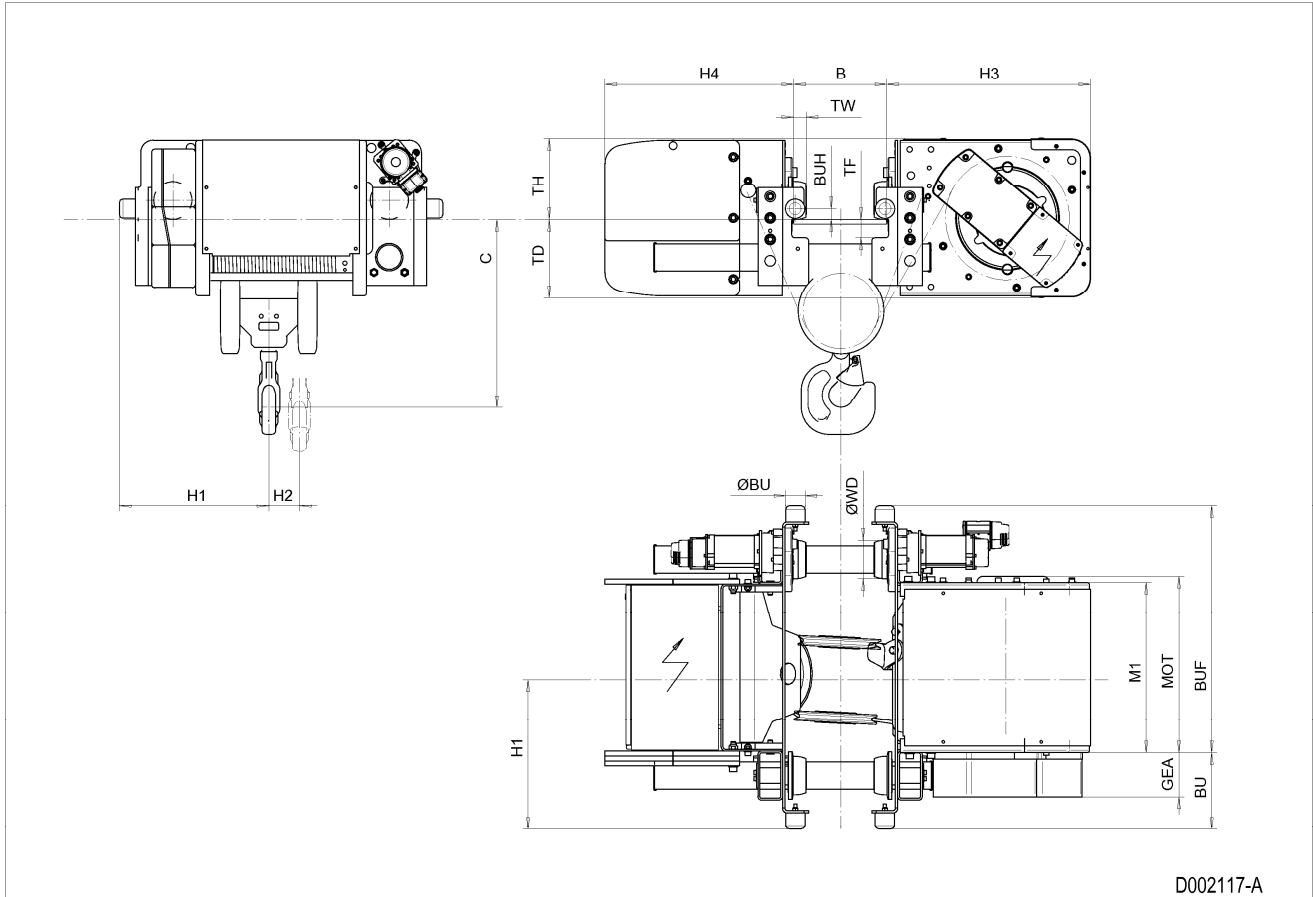

11 LOW HEADROOM HOIST ND, REEVING: 04, EXTENDED LOAD

Hoist dimensions

HOL m	Length code	M1 mm	H2 mm	H3 mm	H3* mm	BUF mm	Weight kg
9	D	558	88	667	687	809	610
12	E	678	118	667	687	929	660
16	F	828	156	667	687	1079	710

Motor dimensions

Motor	P5	P6	P7	A5	S5
MOT (mm)	578	578	618	498	606
Weight (kg)	58	85	105	45	53

Trolley dimensions

B min.	B max.	ØWD	ØBU	BU	BUH	GEA	H1	H4	TD	TF	TH
100	610	150	63	250	48	143	488	618	245	47	277
TW											
44											

D002118_A
005000

C-dimensions

B	C
100 - 199	715
200 - 289	685
290 - 530	655
531 - 610	705

Note: All dimensions in mm.

Note: Weight calculated with P5 motor.

* Please, disregard the dimension H3*.

Low Headroom Hoist ND, REEVING: 04, Extended Load

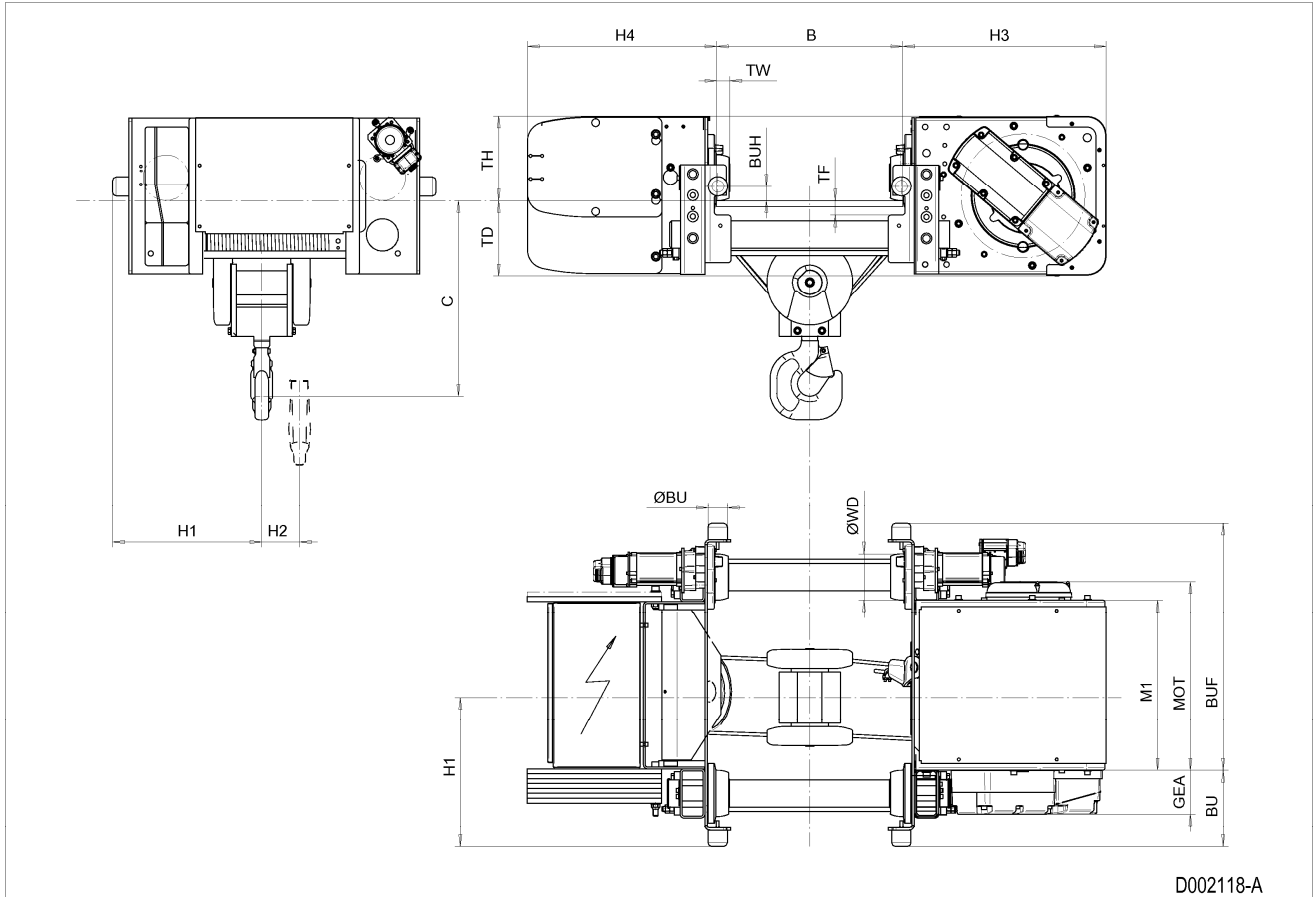

DOUBLE GIRDER TROLLEY, MEDIUM

12 DOUBLE GIRDER HOIST NB, REEVING: 02

Hoist dimensions

HOL m	Length code	M1 mm	M2 mm	H1 mm	H2 mm	Min R mm	Weight kg
12	A	326	424	519	90	1200	220
19	C	456	424	519	144	1200	230

Motor dimensions

Motor	P1	P2	P3	A3	S3
MOT (mm)	386	446	476	446	526
Weight (kg)	21	31	35	32	28

Trolley dimensions

C	ØBU	BU	BUH	E1	E2	E3	GEA	H3	WB	ØWD	W min
320	63	138	90	327	714	15	110	398	820	90	50
W max	RO	TD	TH								
70	83	113	268								

D002076_A
062126

Note: All dimensions in mm.

Note: H1, M2 and weight calculated with P1 motor and Min R.

Note: Min R with second brake.

Note: Standard rail gauges: 1200, 1400, 1700 and 2000.

Note: Flangeless wheels available.

Double Girder Hoist NB, REEVING: 02

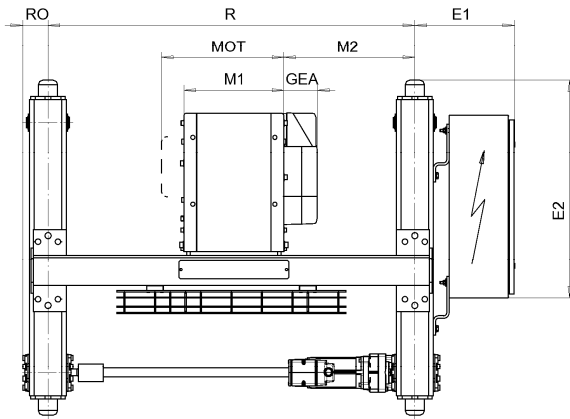
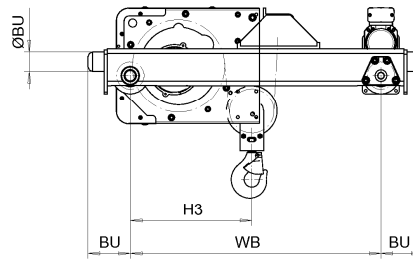
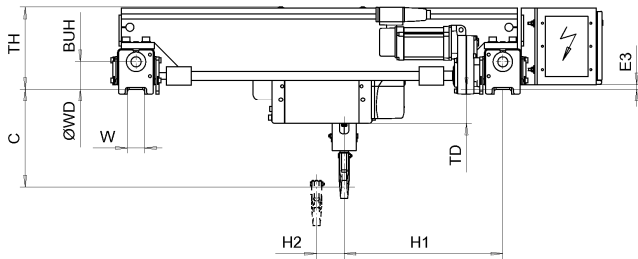

D002076-A

13 DOUBLE GIRDER HOIST NB, REEVING: 04

Hoist dimensions

HOL m	Length code	M1 mm	M2 mm	H1 mm	H2 mm	Min R mm	Weight kg
6	A	326	424	574	45	1200	225
9.5	C	456	424	574	72	1200	235

Motor dimensions

Motor	P1	P2	P3	A3	S3
MOT (mm)	386	446	476	446	526
Weight (kg)	21	31	35	32	28

Trolley dimensions

C	ØBU	BU	BUH	E1	E2	E3	GEA	H3	WB	ØWD	W min
270	63	138	90	327	714	15	110	411	820	90	50
W max	RO	TD	TH								
70	83	113	268								

D002081_A
062127

Note: All dimensions in mm.

Note: H1, M2 and weight calculated with P1 motor and Min R.

Note: Min R with second brake

Note: Standard rail gauges: 1200, 1400, 1700 and 2000.

Note: Flangeless wheels available.

Double Girder Hoist NB, REEVING: 04

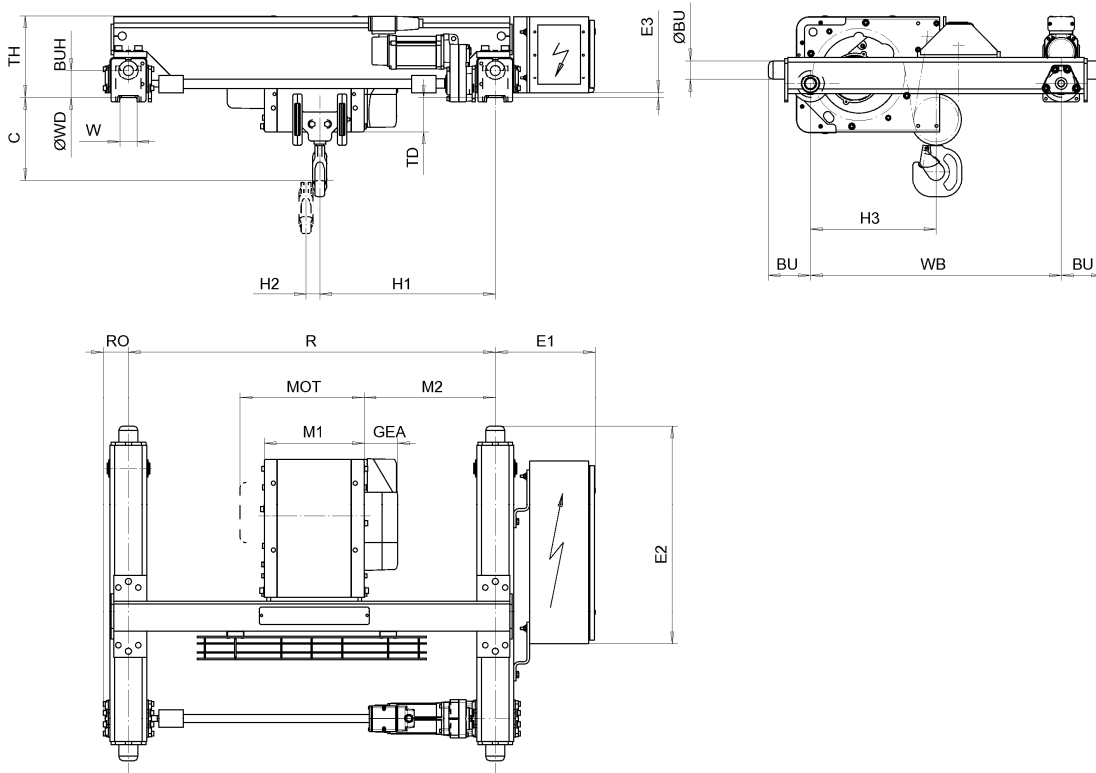

D002081-A

14 DOUBLE GIRDER HOIST NC, REEVING: 02

Hoist dimensions

HOL m	Length code	M1 mm	M2 mm	H1 mm	H2 mm	Min R mm	Weight kg
12	B	356	368	459	95	1200	310
18	C	456	368	459	144	1200	320
24	D	556	468	559	193	1400	335
30	E	676	468	559	252	1400	350

Motor dimensions

Motor	P3	P4	A3	S3	S5
MOT (mm)	473	574	443	523	602
Weight (kg)	35	53	32	28	53

Trolley dimensions

C	ØBU	BU	BUH	E1	E2	E3	GEA	H3	WB	ØWD	W min
360	63	138	90	327	758	12	116	482	1010	90	50
W max	RO	TD	TH								
70	83	126	304								

D002088_A
062138

Note: All dimensions in mm.

Note: H1, M2 and weight calculated with P3 motor and Min R.

Note: Motor S5 is unavailable for load class 3200 kg.

Note: Min R with service platform and second brake.

Note: Standard rail gauges: 1200, 1400, 1700 and 2000.

Note: Flangeless wheels available.

Double Girder Hoist NC, REEVING: 02

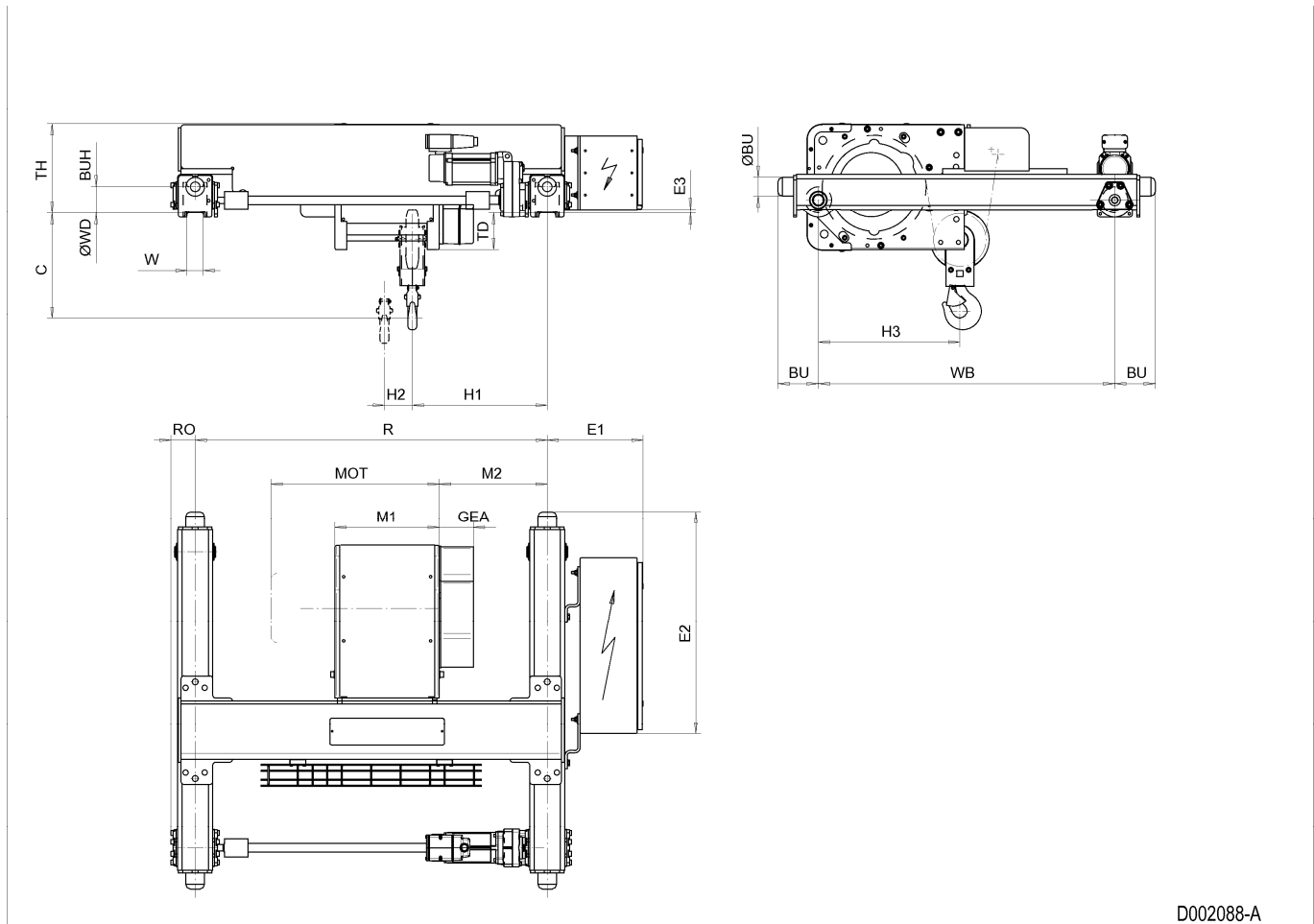

D002088-A

15 DOUBLE GIRDER HOIST NC, REEVING: 04

Hoist dimensions

HOL m	Length code	M1 mm	M2 mm	H1 mm	H2 mm	Min R mm	Weight kg
6	B	356	368	537	49	1200	315
9	C	456	368	537	74	1200	325
12	D	556	468	637	99	1400	340
15	E	676	468	637	129	1400	360

Motor dimensions

Motor	P3	P4	A3	S3	S5
MOT (mm)	473	574	443	523	602
Weight (kg)	35	53	32	28	53

Trolley dimensions

C1	C2	ØBU	BU	BUH	E1	E2	E3	GEA	H3	WB	ØWD
350	366	63	138	90	327	758	12	116	482	1010	90
W min	W max	RO	TD	TH							
50	70	83	126	304							

D002095_A
062139

Note: All dimensions in mm.

Note: H1, M2 and weight calculated with P3 motor and Min R.

Note: Motor S5 is unavailable for load class 6300 kg.

Note: Min R with service platform and second brake.

Note: Standard rail gauges: 1200, 1400, 1700 and 2000.

Note: Flangeless wheels available.

Double Girder Hoist NC, REEVING: 04

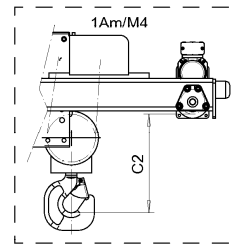
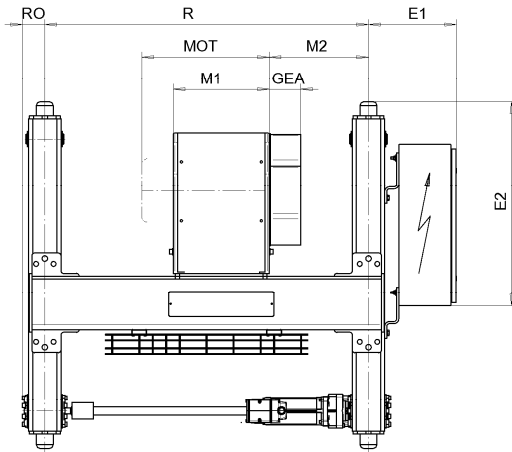
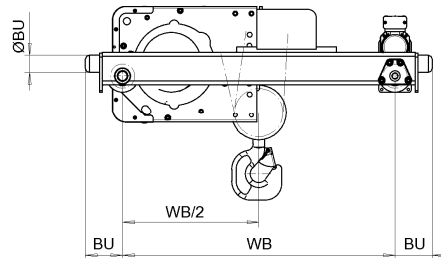
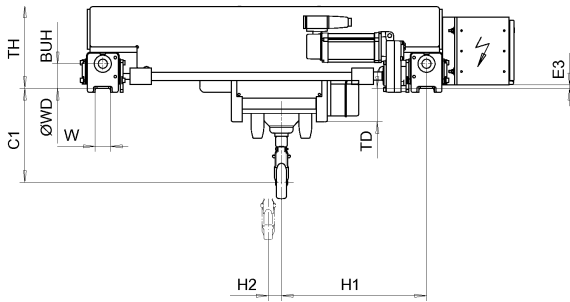

D002095-A

16 DOUBLE GIRDER HOIST ND, REEVING: 02

Hoist dimensions

HOL m	Length code	M1 mm	M2 mm	H1 mm	H2 mm	Min R mm	Weight kg
18	D	558	403	558	176	1400	650
24	E	678	403	558	235	1400	675
32	F	828	516	671	309	1700	720
40	G	1018	666	821	403	2000	760

Motor dimensions

Motor	P5	P6	P7	A5	S5	S7
MOT (mm)	578	578	618	498	606	757
Weight (kg)	58	85	105	45	53	81

Trolley dimensions

C	ØBU	BU	BUH	E1	E2	E3	GEA	H3	WB	ØWD	W min
476	63	148	100	382	1028	15	143	552	1080	110	52
W max	RO	TD	TH								
87	98	90	426								

D002113_A
005020

Note: All dimensions in mm.

Note: H1, M2 and weight calculated with P5 motor and Min R.

Note: Motor S7 is unavailable for load class 6300 kg.

Note: Min R with service platform and second brake.

Note: Standard rail gauges: 1400, 1700 and 2000.

Note: Flangeless wheels available.

Double Girder Hoist ND, REEVING: 02

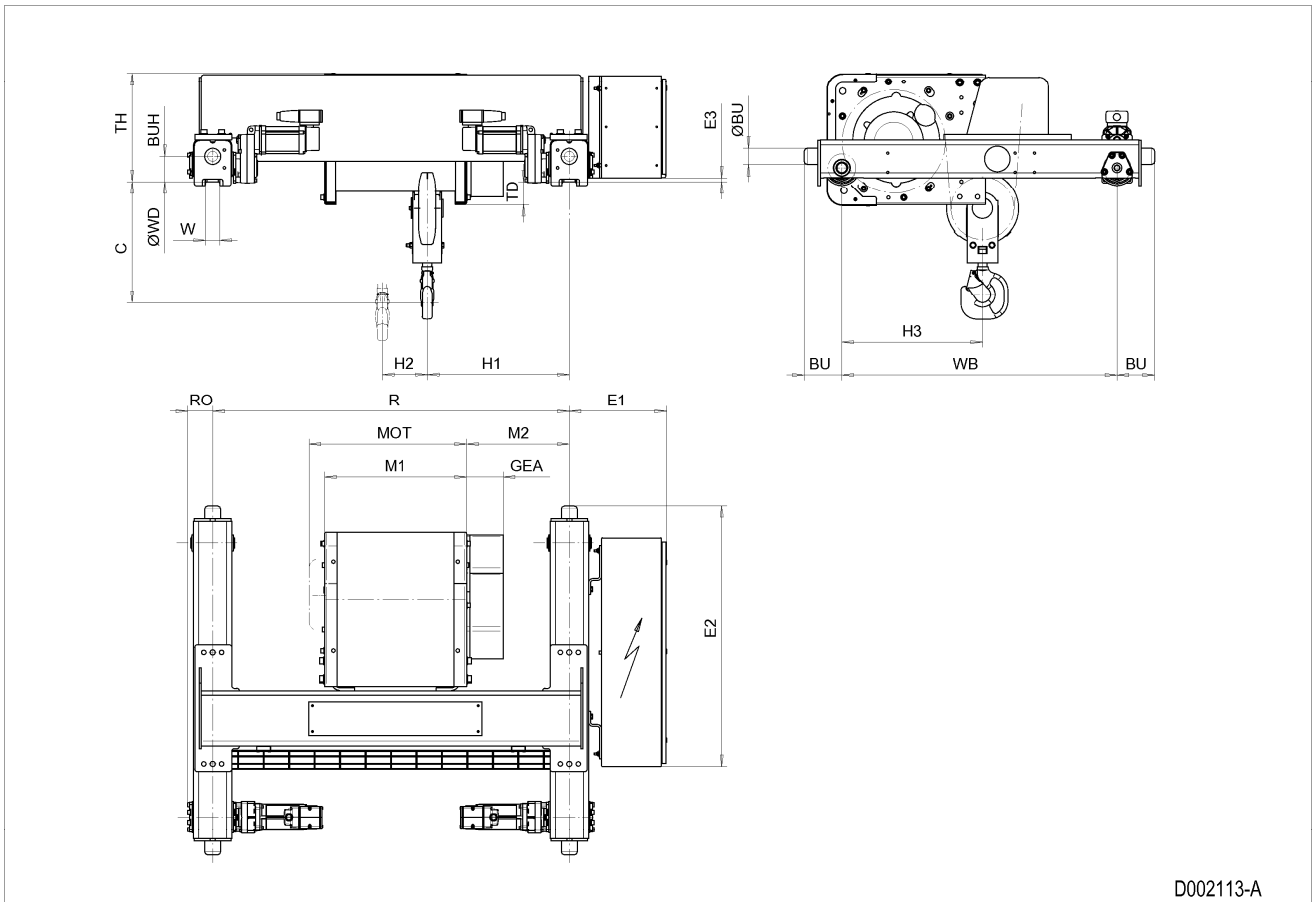

D002113-A

17 DOUBLE GIRDER HOIST ND, REEVING: 04

Hoist dimensions

HOL m	Length code	M1 mm	M2 mm	H1 mm	H2 mm	Min R mm	Weight kg
9	D	558	403	640	88	1400	670
12	E	678	403	640	118	1400	700
16	F	828	516	753	156	1700	745
20	G	1018	666	903	201	2000	785

Motor dimensions

Motor	P5	P6	P7	A5	S5	S7
MOT (mm)	578	578	618	498	606	757
Weight (kg)	58	85	105	45	53	81

Trolley dimensions

C1	C2	ØBU	BU	BUH	E1	E2	E3	GEA	H3	WB	ØWD
421	477	63	148	100	382	1028	15	143	585	1080	110
W min	W max	RO	TD	TH							
52	87	98	90	426							

D002119_A
005021

Note: All dimensions in mm.

Note: Weight calculated with P5 motor.

Note: Motor S7 is unavailable for load class 12500 kg.

Note: Min R with service platform and second brake.

Note: Standard rail gauges: 1400, 1700 and 2000.

Note: Flangeless wheels available.

Double Girder Hoist ND, REEVING: 04

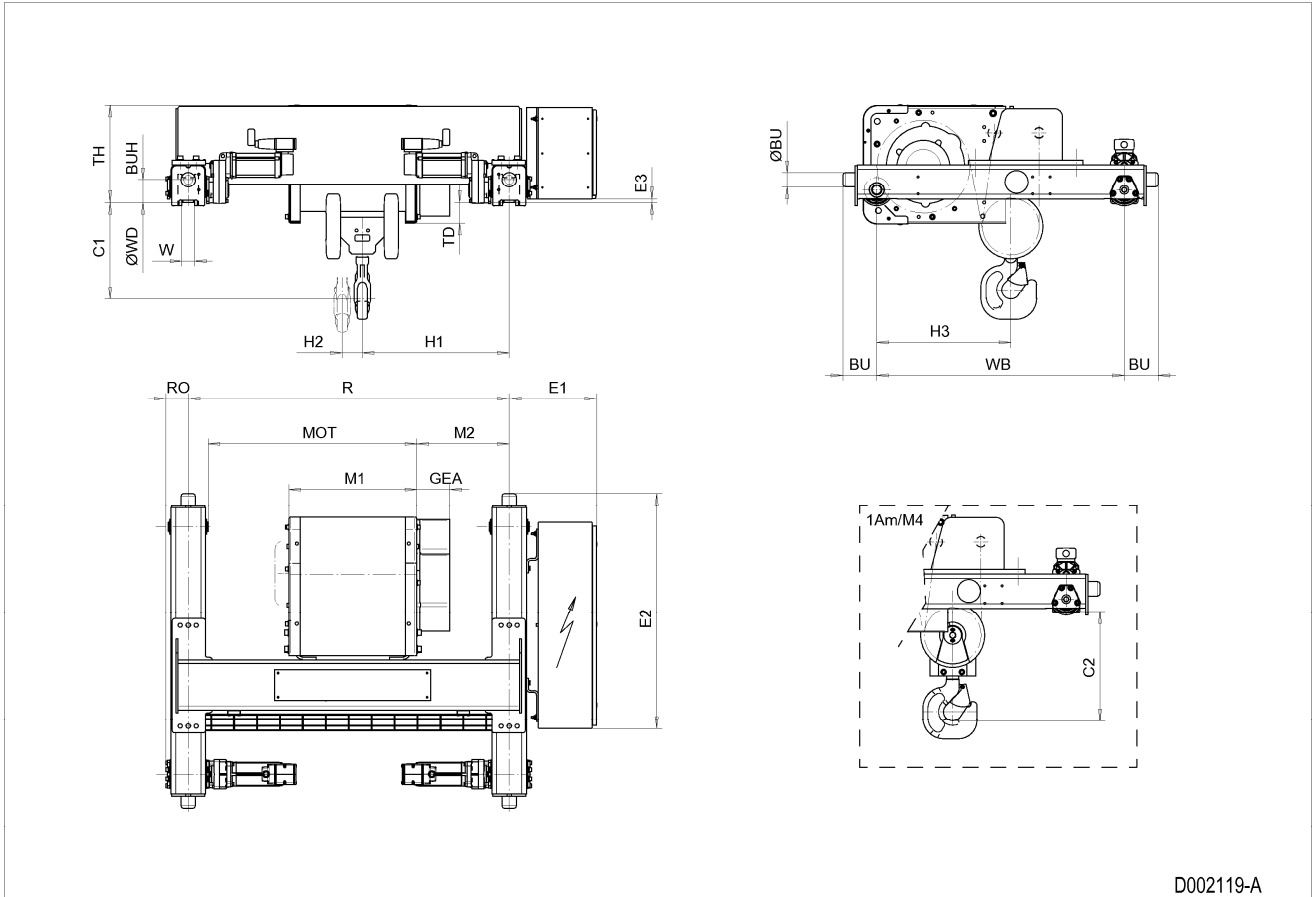

D002119-A

18 DOUBLE GIRDER HOIST ND, REEVING: 06

Hoist dimensions

HOL m	Length code	M1 mm	M2 mm	H1 mm	H2 mm	Min R mm	Weight kg
6	D	558	538	505	53	1400	760
8	E	678	758	725	78	1700	805
10	F	828	913	880	98	2000	850
13	G	1018	1123	1090	132	2400	915

Motor dimensions

Motor	P5	P6	P7	A5	S5	S7
MOT (mm)	578	578	618	498	606	757
Weight (kg)	58	85	105	45	53	81

Trolley dimensions

C	ØBU	BU	BUH	E1	E2	E3	GEA	WB	ØWD	W min	W max
790	63	163	100	382	1343	18	143	1080	140	54	84
RO	TD	TH									
98	94	430									

D007194_A
124515

Note: All dimensions in mm.

Note: Weight calculated with P5 motor.

Note: Min R with service platform and second brake.

Note: Standard rail gauges: 1400, 1700, 2000 and 2400.

Note: H1, M2 and weight calculated with Min R.

Note: Flangeless wheels available.

Double Girder Hoist ND, REEVING: 06

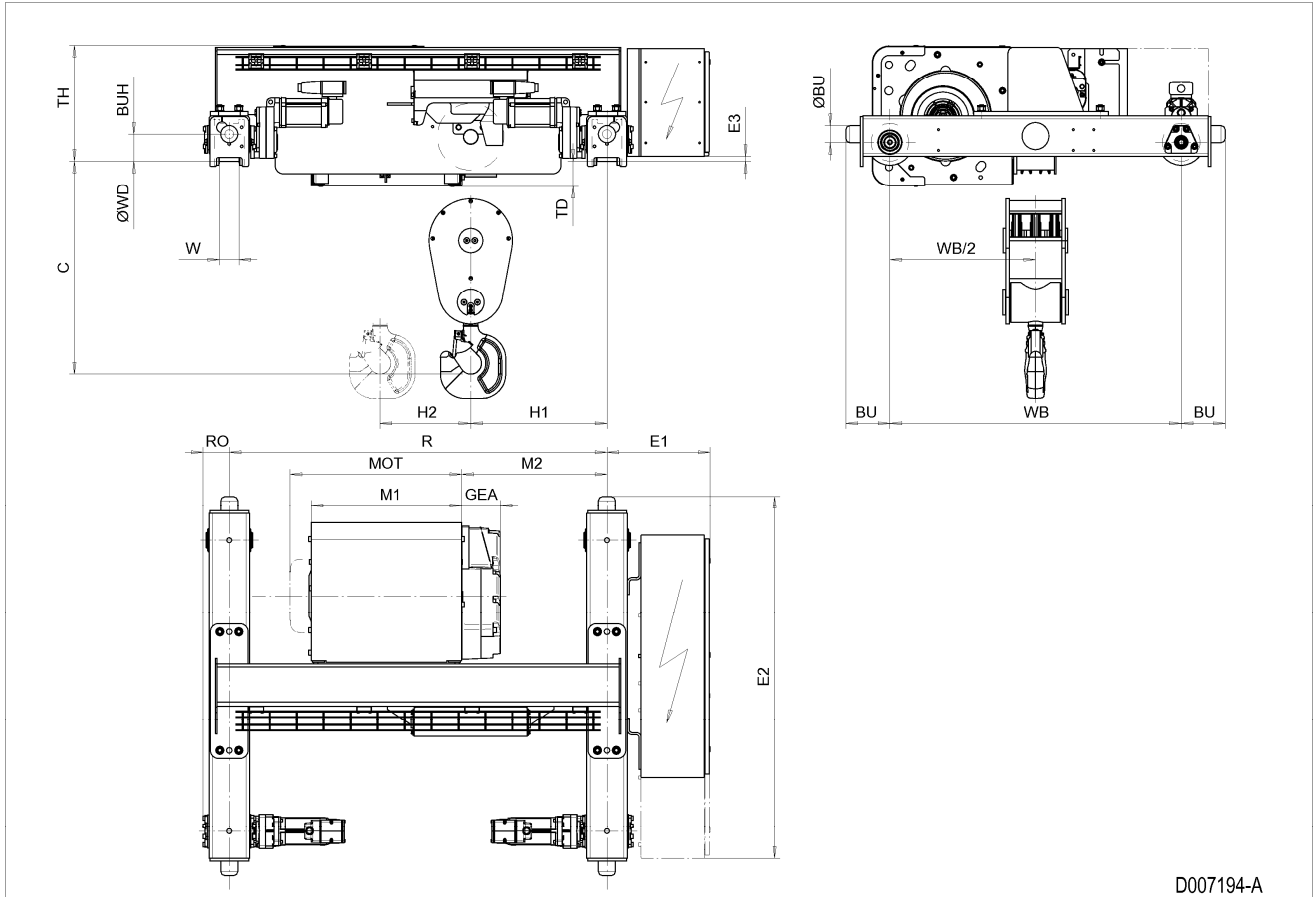

D007194-A

19 DOUBLE GIRDER HOIST ND, REEVING: 08

Hoist dimensions

HOL m	Length code	M1 mm	M2 mm	H1 mm	H2 mm	Min R mm	Weight kg
4.5	D	558	538	505	44	1400	770
6	E	678	758	725	53	1700	815
8	F	828	913	880	76	2000	865
10	G	1018	1123	1090	98	2400	925

Motor dimensions

Motor	P5	P6	P7	A5	S5	S7
MOT (mm)	578	578	618	498	606	757
Weight (kg)	58	85	105	45	53	81

Trolley dimensions

C	ØBU	BU	BUH	E1	E2	E3	GEA	WB	ØWD	W min	W max
790	63	163	100	382	1343	18	143	1080	140	54	84
RO	TD	TH									
98	94	430									

D007195_A
124516

Note: All dimensions in mm.

Note: Weight calculated with P5 motor.

Note: Min R with service platform and second brake.

Note: Standard rail gauges: 1400, 1700, 2000 and 2400.

Note: H1, M2 and weight calculated with Min R.

Note: Flangeless wheels available.

Double Girder Hoist ND, REEVING: 08

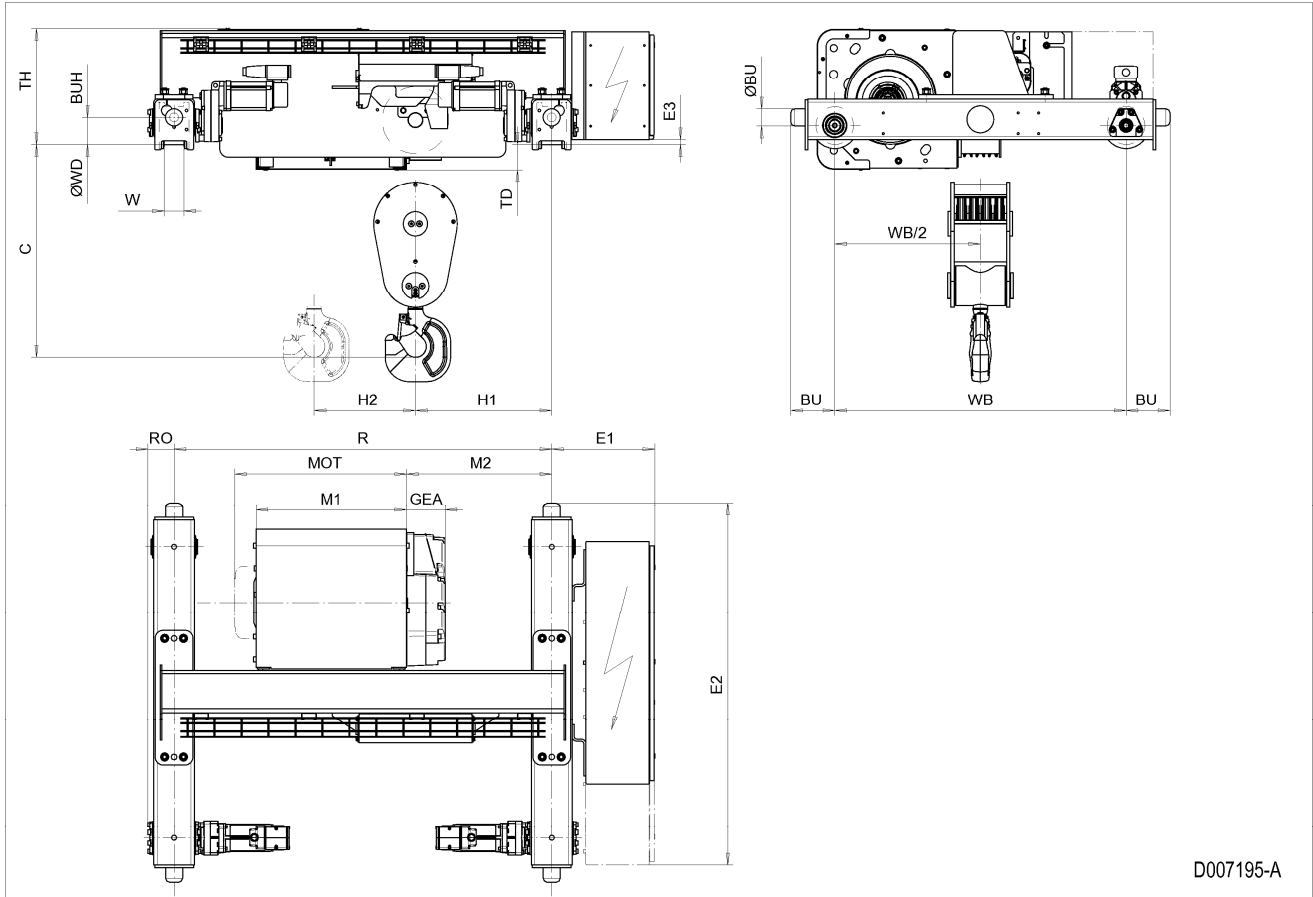

D007195-A

20 DOUBLE GIRDER HOIST ND, REEVING: 22

Hoist dimensions

HOL m	Length code	H1 mm	M1 mm	M2 mm	BRA mm	Min R mm	Weight kg
8.5	D	733	558	454	-	1400	660
13	E	733	678	394	-	1400	680
18	F	883	828	469	-	1700	730
25	G	883	1018	374	-	1700	760
33.5	H	1033	1268	399	128	2000	840
46	J	1233	1618	424	128	2400	925

Motor dimensions

Motor	P5	P6	P7	A5	S5	S7
MOT (mm)	578	578	618	498	606	757
Weight (kg)	58	85	105	45	53	81

Trolley dimensions

C	ØBU	BU	BUH	E1	E2	E3	GEA	H3	WB	ØWD	W min
620	63	148	100	382	1328	15	143	585	1080	110	52
W max	RO	TD	TH								
87	98	97	427								

D007171_A
124132

Note: All dimensions in mm.

Note: Weight calculated with P5 motor.

Note: Min R with service platform and second brake.

Note: Standard rail gauges: 1400, 1700, 2000 and 2400.

Note: Gear brake as standard brake for drum lengths H and J.

Note: H1, M2 and weight calculated with Min R.

Note: Flangeless wheels available.

Double Girder Hoist ND, REEVING: 22

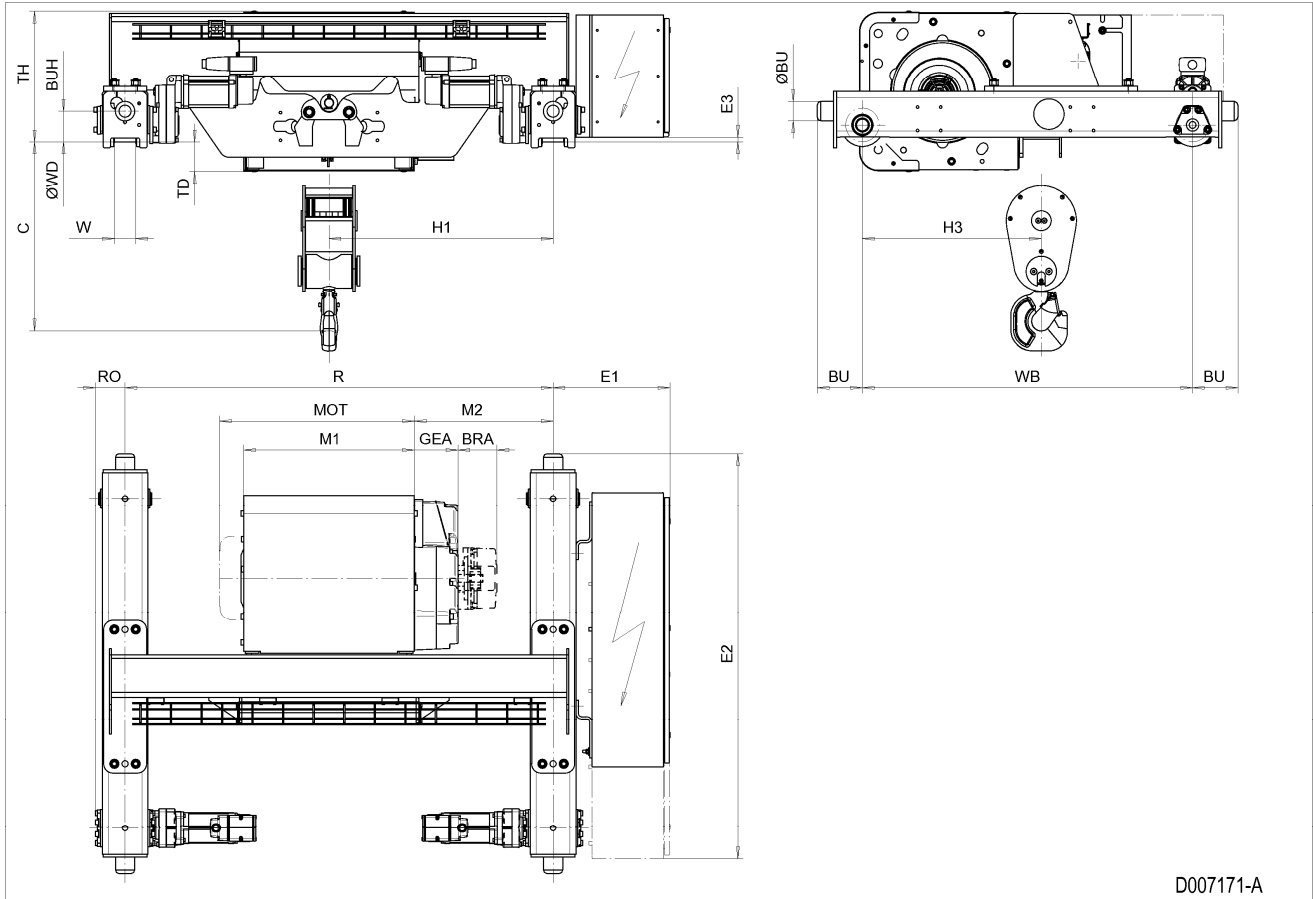

D007171-A

21 DOUBLE GIRDER HOIST ND, REEVING: 24

Hoist dimensions

HOL m	Length code	H1 mm	M1 mm	M2 mm	BRA mm	Min R mm	Weight kg
4	D	733	558	454	-	1400	725
6.5	E	733	678	394	-	1400	745
9	F	883	828	469	-	1700	795
12.5	G	883	1018	374	-	1700	825
16.5	H	1033	1268	399	128	2000	900
23	J	1233	1618	424	128	2400	990

Motor dimensions

Motor	P5	P6	P7	A5	S5	S7
MOT (mm)	578	578	618	498	606	757
Weight (kg)	58	85	105	45	53	81

Trolley dimensions

C	ØBU	BU	BUH	E1	E2	E3	GEA	H3	WB	ØWD	W min
785	63	148	100	382	1328	15	143	585	1080	110	52
W max	RO	TD	TH								
87	98	97	427								

D007172_A
124133

Note: All dimensions in mm.

Note: Weight calculated with P5 motor.

Note: Min R with service platform and second brake.

Note: Standard rail gauges: 1400, 1700, 2000 and 2400.

Note: Gear brake as standard brake for drum lengths H and J.

Note: H1, M2 and weight calculated with Min R.

Note: Flangeless wheels available.

Double Girder Hoist ND, REEVING: 24

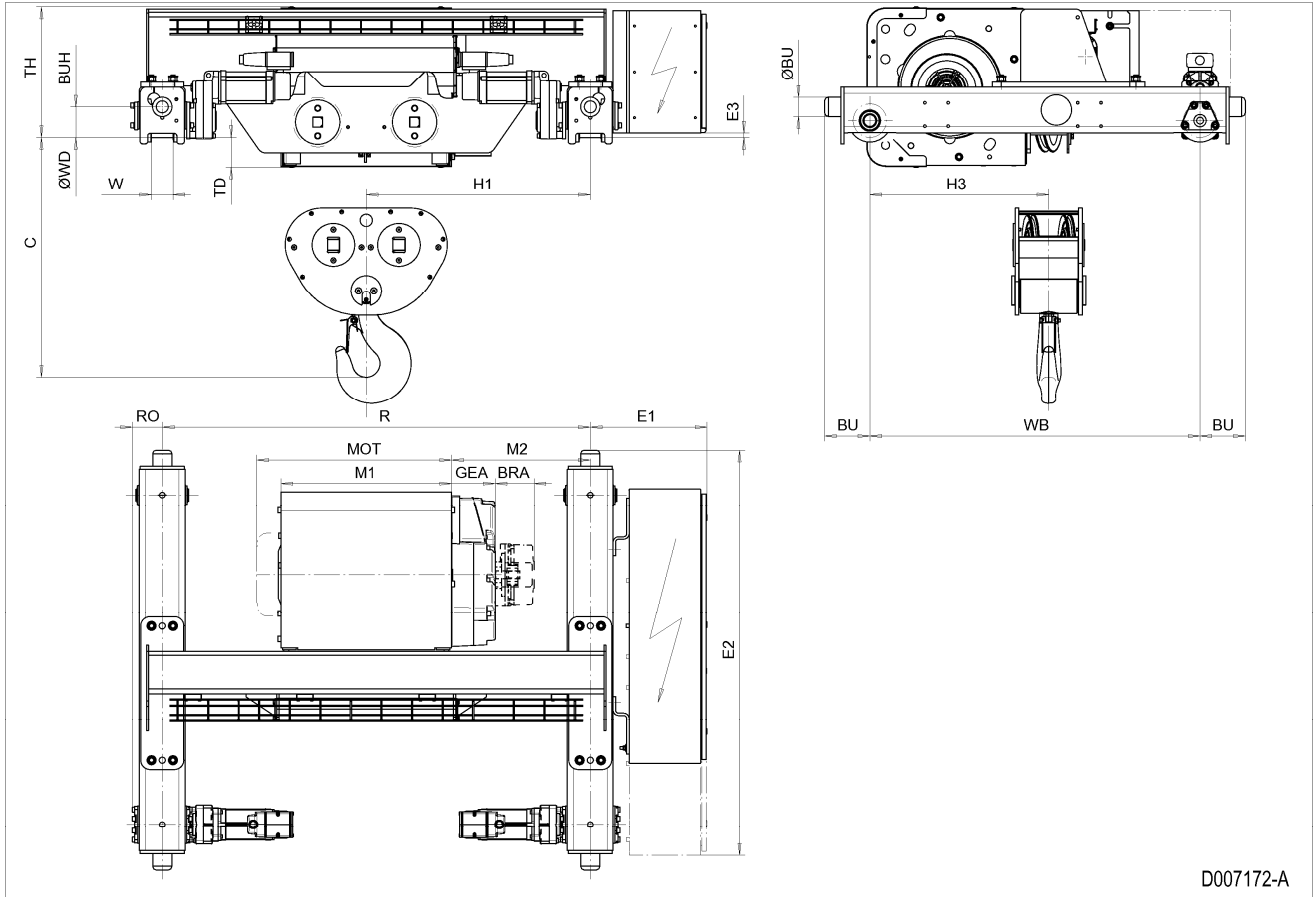

D007172-A

22 DOUBLE GIRDER HOIST ND, REEVING: 26

Hoist dimensions

HOL m	Length code	H1 mm	M1 mm	M2 mm	BRA mm	Min R mm	Weight kg
4	E	733	678	394	-	1400	780
6	F	883	828	469	-	1700	825
8	G	883	1018	374	-	1700	855
11	H	1033	1268	399	128	2000	935
15	J	1233	1618	424	128	2400	1020

Motor dimensions

Motor	P5	P6	P7	A5	S5	S7
MOT (mm)	578	578	618	498	606	757
Weight (kg)	58	85	105	45	53	81

Trolley dimensions

C	ØBU	BU	BUH	E1	E2	E3	GEA	WB	ØWD	W min	W max
785	63	163	100	382	1343	18	143	1080	140	54	84
RO	TD	TH									
98	94	430									

D007173_A
124134

Note: All dimensions in mm.

Note: Weight calculated with P5 motor.

Note: Min R with service platform and second brake.

Note: Standard rail gauges: 1400, 1700, 2000 and 2400.

Note: Gear brake as standard brake for drum lengths H and J.

Note: H1, M2 and weight calculated with Min R.

Note: Flangeless wheels available.

Double Girder Hoist ND, REEVING: 26

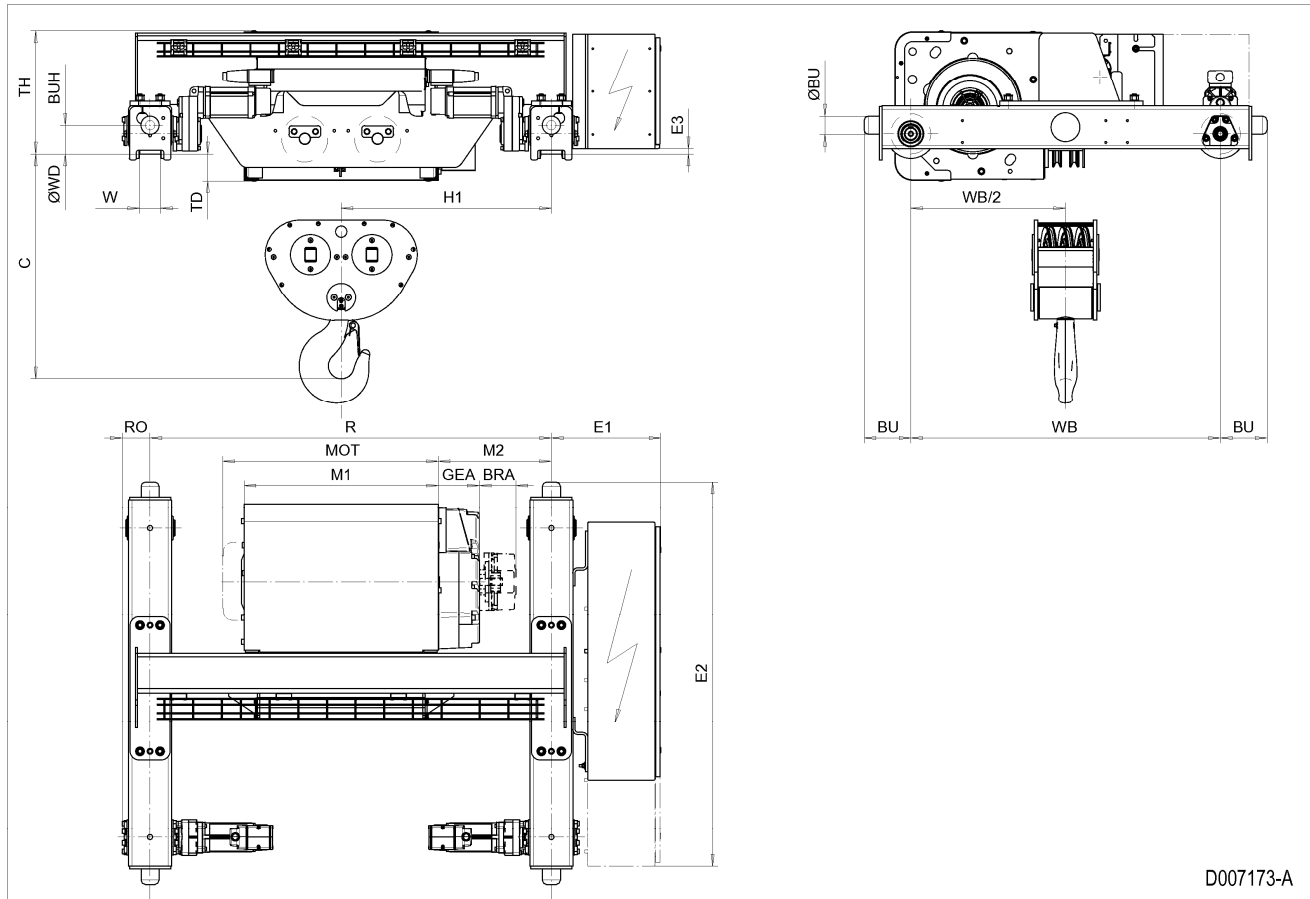

D007173-A

23 DOUBLE GIRDER HOIST ND, REEVING: 28

Hoist dimensions

HOL m	Length code	H1 mm	M1 mm	M2 mm	BRA mm	Min R mm	Weight kg
4.5	F	883	828	469	-	1700	840
6	G	883	1018	374	-	1700	870
8	H	1033	1268	399	128	2000	945
11.5	J	1233	1618	424	128	2400	1030

Motor dimensions

Motor	P5	P6	P7	A5	S5	S7
MOT (mm)	578	578	618	498	606	757
Weight (kg)	58	85	105	45	53	81

Trolley dimensions

C	ØBU	BU	BUH	E1	E2	E3	GEA	WB	ØWD	W min	W max
785	63	163	100	382	1343	18	143	1080	140	54	84
RO	TD	TH									
98	94	430									

D007174_A
124135

Note: All dimensions in mm.

Note: Weight calculated with P5 motor.

Note: Min R with service platform and second brake.

Note: Standard rail gauges: 1700, 2000 and 2400.

Note: Gear brake as standard brake for drum lengths H and J.

Note: H1, M2 and weight calculated with Min R.

Note: Flangeless wheels available.

Double Girder Hoist ND, REEVING: 28

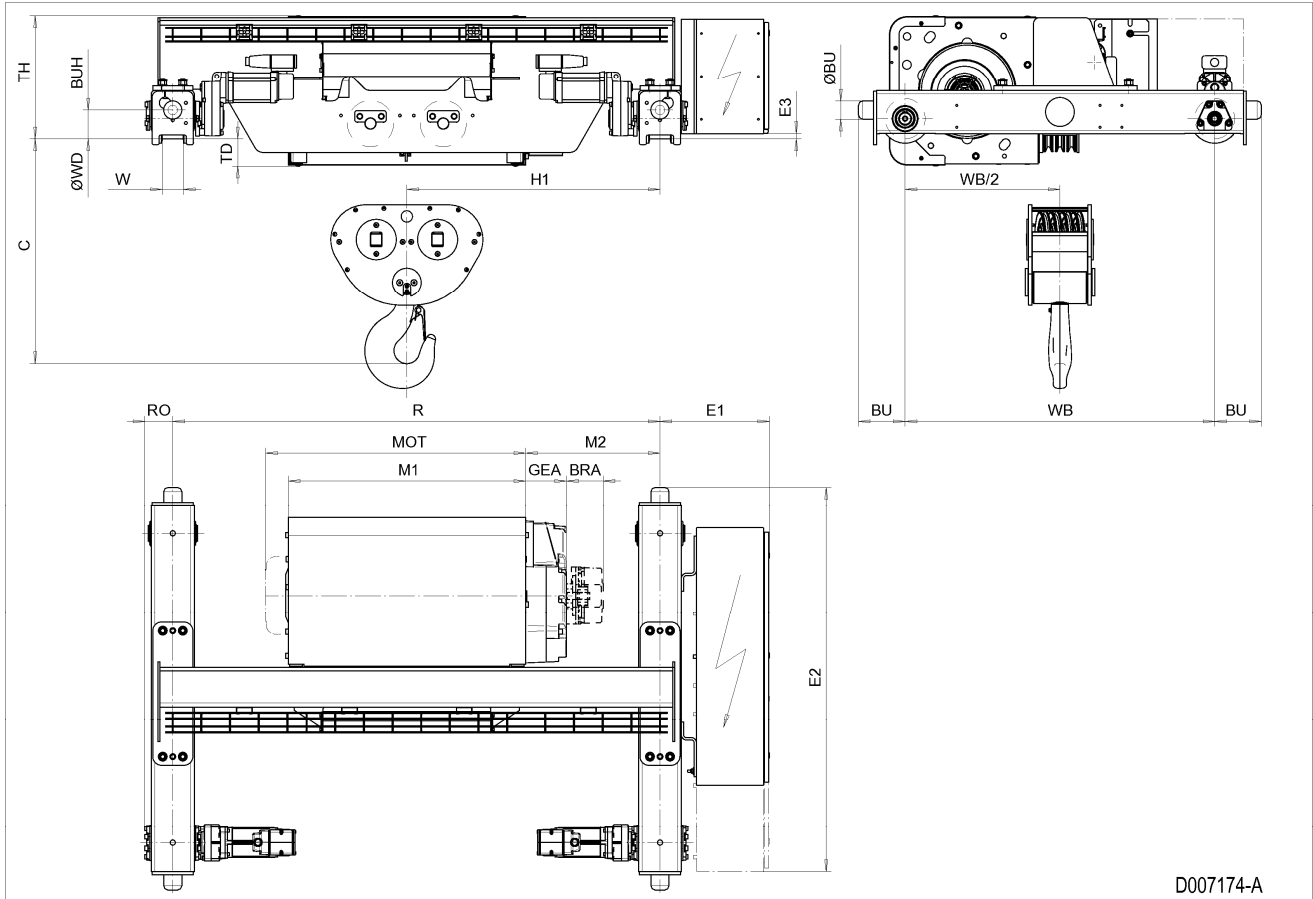

D007174-A

24 DOUBLE GIRDER HOIST NE, REEVING: 02

Hoist Dimensions

HOL m	HOL* m	Length code	M1 mm	M2 mm	H1 mm	H2 mm	Min R mm	Max R mm	Weight** kg
15.5	10	C	462	714	654	139	1400	1400	1250
21	15.5	D	562	799	739	188	1700	2700	1320
28	22.5	E	682	799	739	251	1700	3100	1370
36	30.5	F	832	949	889	322	2000	3100	1460
47	41.5	G	1022	1149	1089	421	2400	3100	1570
61	55.5	H	1272	1469	1409	546	3100	3800	1750
80.5	75	J	1622	1559	1499	721	3400	4200	1950
97	91.5	K	1922	1944	1884	868	4200	4200	2200

*HOL with drum brake.

**Presence of a drum brake will increase weight by 80 kgs.

Motor Dimensions

Motor	P6	P7	P8	A7	S7	S8	SA
MOT (mm)	536	576	711	536	715	763	803
Weight (kg)	85	105	106	71	81	97	120

Trolley Dimensions

C	ØWD	ØBU	BU	BUH	E1	E2	E3	GEA	H3	H4	M3
892	140	63	163	100	488	1842	18	218	757	743	44
RO	TD	TH	WB	W min	W max						
101	90	631	1500	54	84						

D006647_A
090649

Note: All dimensions in mm.

Note: Weight calculated with P6 motor.

Note: Standard rail gauges: 1400, 1700, 2000, 2400, 2700, 3100, 3400, 3800 and 4200.

Note: H1, M2 and weight calculated with min R.

Note: Flangeless wheels available.

Double Girder Hoist NE, REEVING: 02

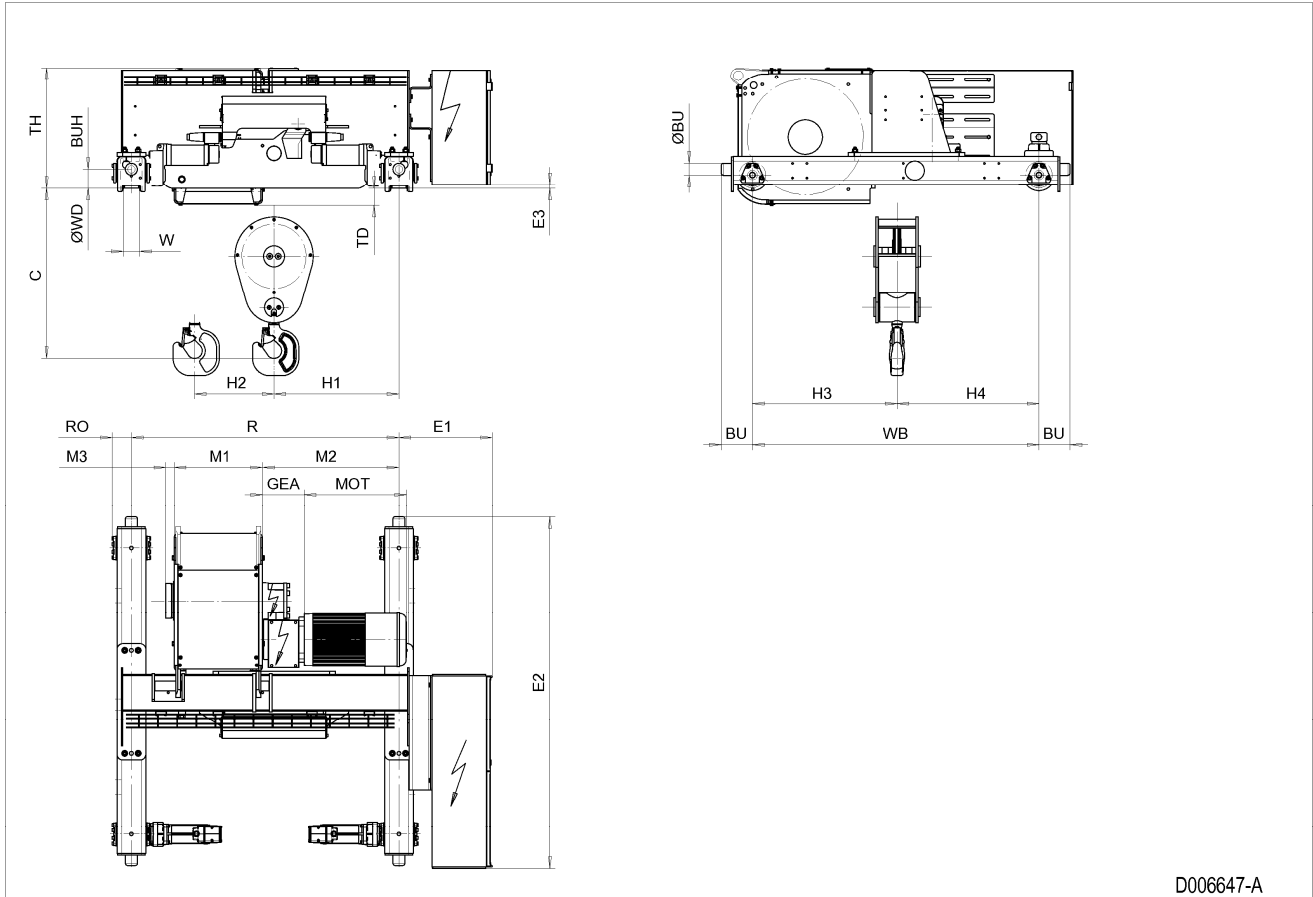

D006647-A

25 DOUBLE GIRDER HOIST NE, REEVING: 04

Hoist Dimensions

HOL m	HOL* m	Length code	M1 mm	M2 mm	H1 mm	H2 mm	Min R mm	Max R mm	Weight** kg
7.5	4.5	C	462	714	654	69	1400	1400	1290
10.5	7.5	D	562	799	739	94	1700	2700	1360
14	11	E	682	799	739	125	1700	3100	1410
18	15	F	832	949	889	161	2000	3100	1500
23.5	20.5	G	1022	1149	1089	210	2400	3100	1620
30.5	27.5	H	1272	1469	1409	273	3100	3800	1790
40	37	J	1622	1559	1499	360	3400	4200	2000
48.5	45.5	K	1922	1944	1884	434	4200	4200	2240

*HOL with drum brake

**Presence of a drum brake will increase weight by 80 kgs.

Motor Dimensions

Motor	P6	P7	P8	A7	S7	S8	SA
MOT (mm)	536	576	711	536	715	763	803
Weight (kg)	85	105	106	71	81	97	120

Trolley Dimensions

C	ØWD	ØBU	BU	BUH	E1	E2	E3	GEA	H3	H4	M3
892	140	63	163	100	488	1842	18	218	757	743	44
RO	TD	TH	WB	W min	W max						
101	90	631	1500	54	84						

D006648_A
090650

Note: All dimensions in mm.

Note: Weight calculated with P6 motor.

Note: Standard rail gauges: 1400, 1700, 2000, 2400, 2700, 3100, 3400, 3800 and 4200.

Note: H1, M2 and weight calculated with min R.

Note: Flangeless wheels available.

Double Girder Hoist NE, REEVING: 04

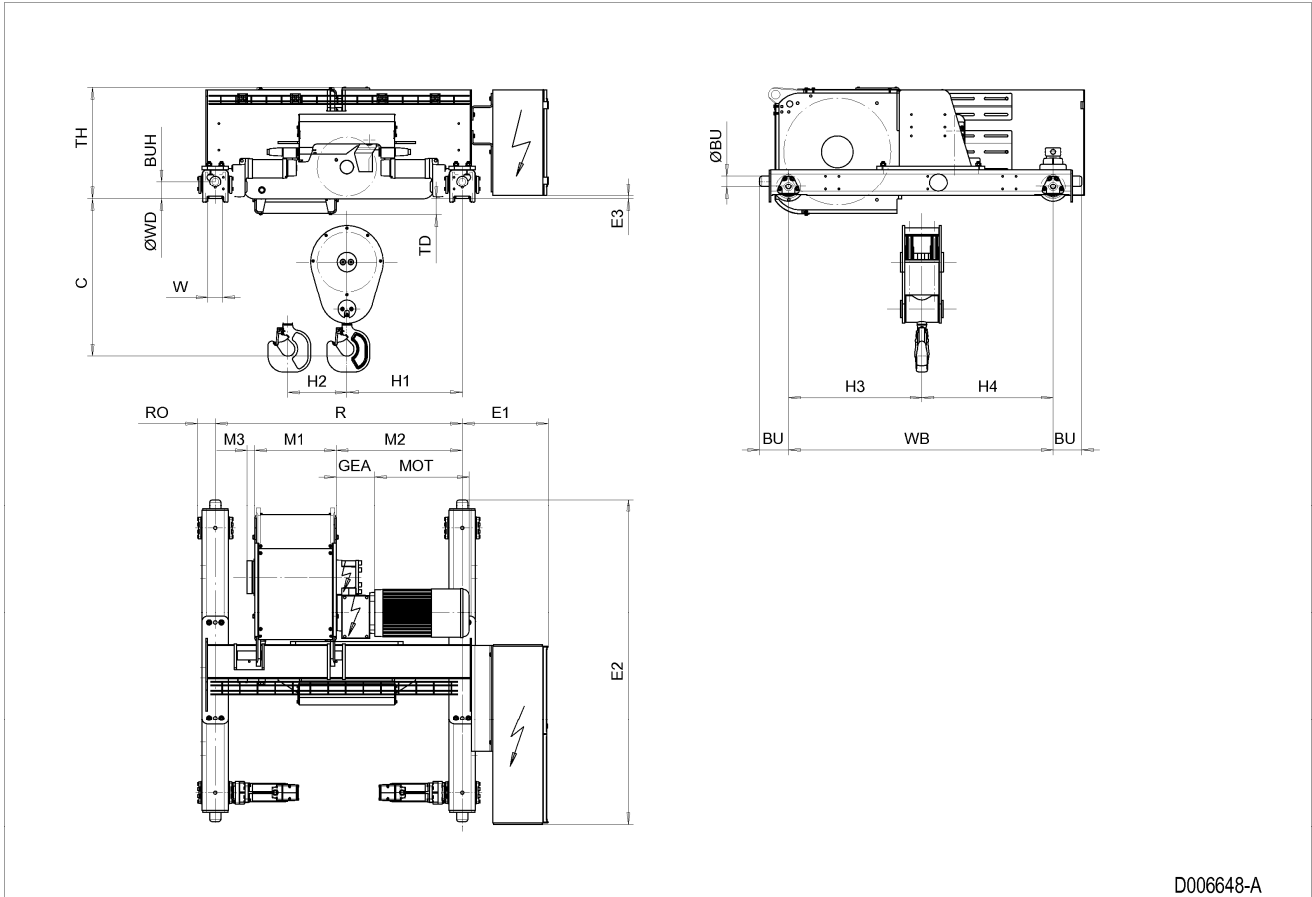

D006648-A

26 DOUBLE GIRDER HOIST NE, REEVING: 06

Hoist Dimensions

HOL m	HOL* m	Length code	M1 mm	M2 mm	H1 mm	H2 mm	Min R mm	Max R mm	Weight** kg
5	3	C	462	714	654	46	1400	1400	1570
7	5	D	562	799	739	63	1700	2700	1650
9	7	E	682	799	739	84	1700	3100	1700
12	10	F	832	949	889	107	2000	3100	1800
15.5	13.5	G	1022	1149	1089	140	2400	3100	1940
20	18	H	1272	1469	1409	182	3100	3800	2210
26.5	24.5	J	1622	1559	1499	240	3400	4200	2430
32	30	K	1922	1944	1884	289	4200	4200	2820

*HOL with drum brake

**Presence of a drum brake will increase weight by 80 kgs.

Motor Dimensions

Motor	P6	P7	P8	A7	S7	S8	SA
MOT (mm)	536	576	711	536	715	763	803
Weight (kg)	85	105	106	71	81	97	120

Trolley Dimensions

C	ØWD	ØBU	BU	BUH	E1	E2	E3	GEA	H3	H4	M3
949	200	80	226	100	488	1860	80	218	712	698	44
RO	TD	TH	WB	W min	W max						
122	28	693	1410	54	99						

D006649_A
090651

Note: All dimensions in mm.

Note: Weight calculated with P6 motor.

Note: Standard rail gauges: 1400, 1700, 2000, 2400, 2700, 3100, 3400, 3800 and 4200.

Note: H1, M2 and weight calculated with min R.

Note: Flangeless wheels available.

Double Girder Hoist NE, REEVING: 06

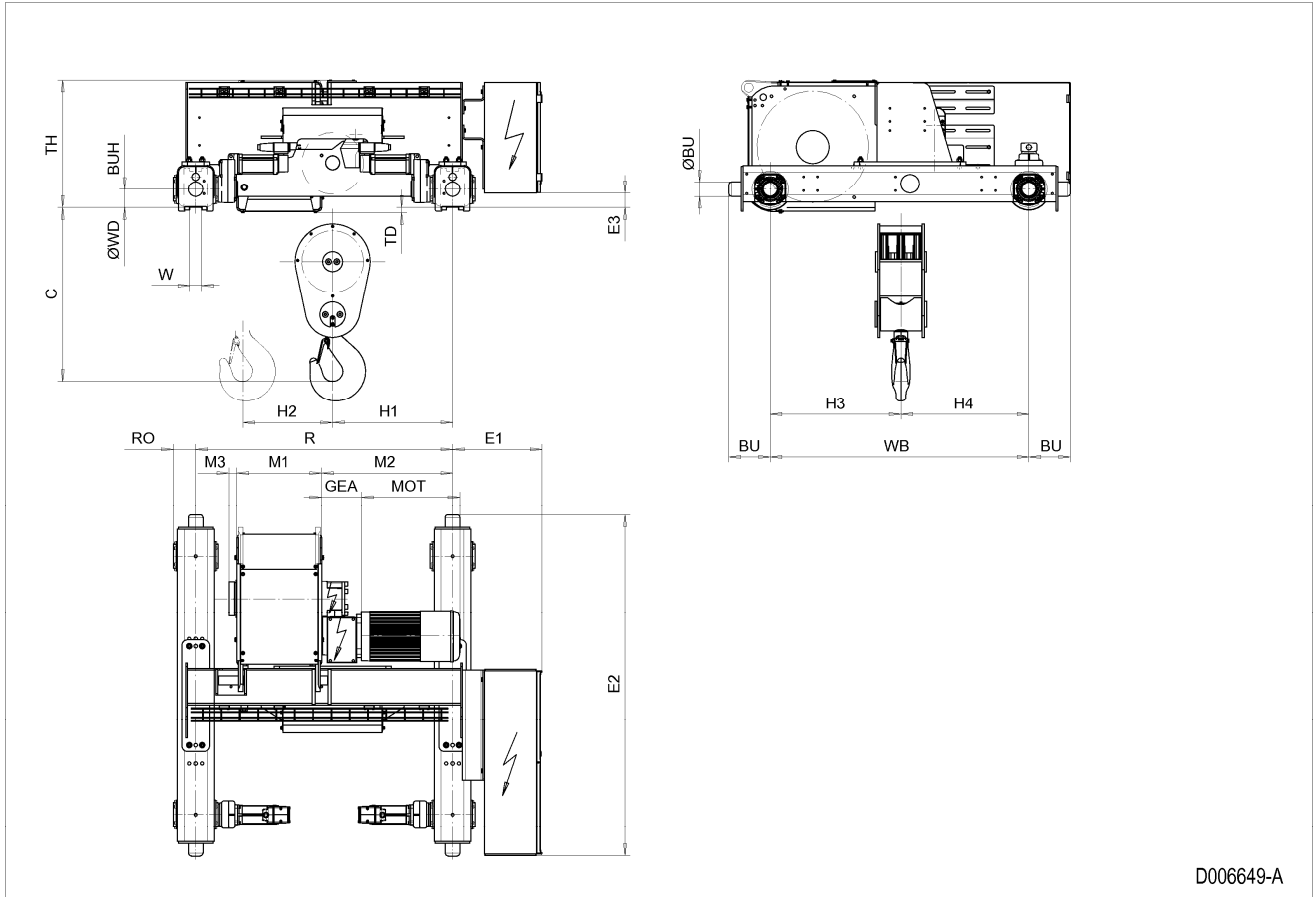

D006649-A

27 DOUBLE GIRDER HOIST NE, REEVING: 08

Hoist Dimensions

HOL m	HOL* m	Length code	M1 mm	M2 mm	H1 mm	H2 mm	Min R mm	Max R mm	Weight** kg
7	5.5	E	682	799	739	63	1700	3100	1780
9	7.5	F	832	949	889	81	2000	3100	1880
11.5	10	G	1022	1149	1089	105	2400	3100	2010
15	13.5	H	1272	1469	1409	137	3100	3800	2280
20	18.5	J	1622	1559	1499	180	3400	4200	2510
24	22.5	K	1922	1944	1884	217	4200	4200	2890

*HOL with drum brake

**Presence of a drum brake will increase weight by 80 kgs.

Motor Dimensions

Motor	P6	P7	P8	A7	S7	S8	SA
MOT (mm)	536	576	711	536	715	763	803
Weight (kg)	85	105	106	71	81	97	120

Trolley Dimensions

C	ØWD	ØBU	BU	BUH	E1	E2	E3	GEA	H3	H4	M3
1105	200	80	226	100	488	1860	80	218	712	698	44
RO	TD	TH	WB	W min	W max						
122	28	693	1410	54	99						

D006650_A
090652

Note: All dimensions in mm.

Note: Weight calculated with P6 motor.

Note: Standard rail gauges: 1700, 2000, 2400, 2700, 3100, 3400, 3800 and 4200.

Note: H1, M2 and weight calculated with min R.

Note: Flangeless wheels available.

Double Girder Hoist NE, REEVING: 08

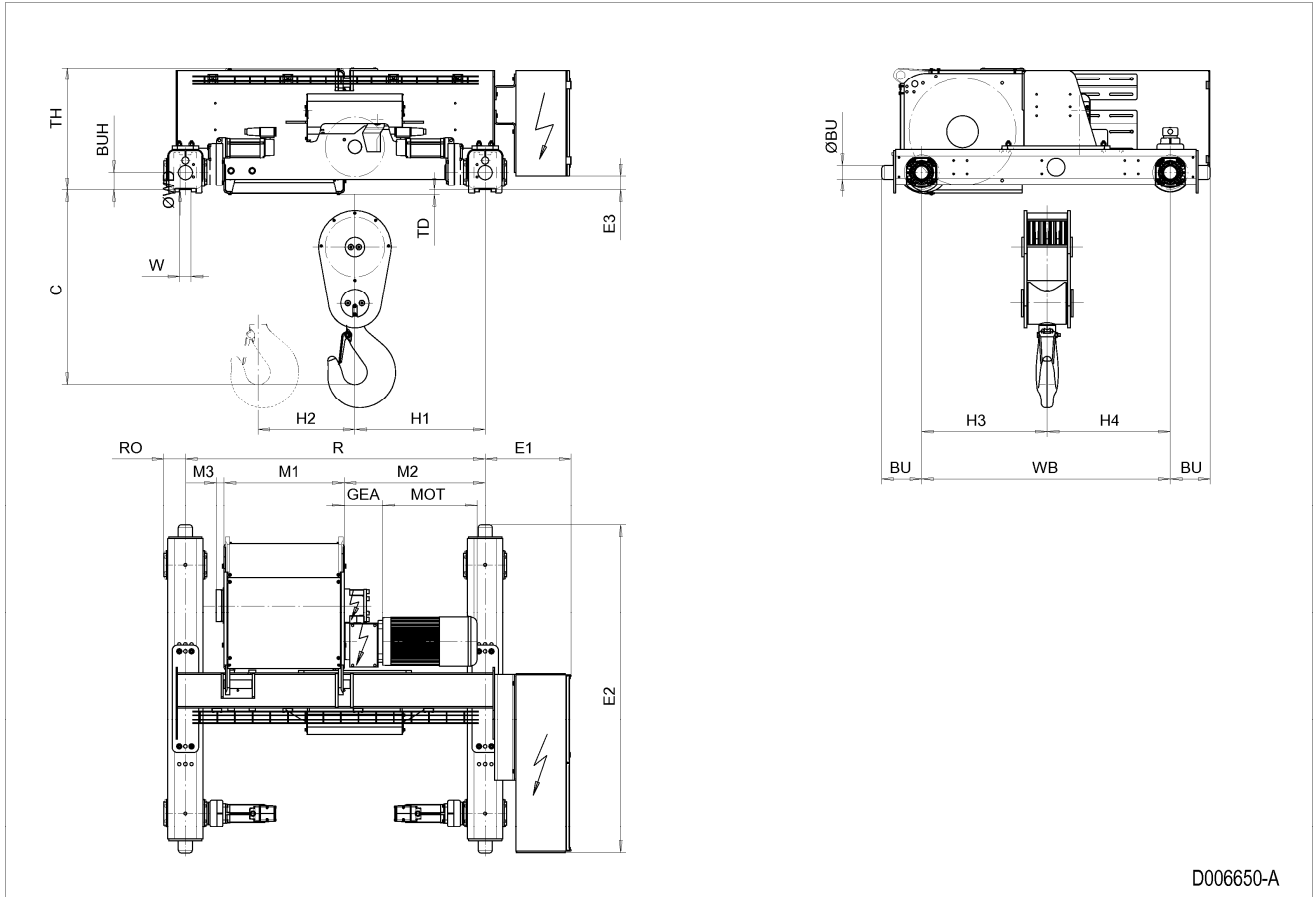

28 DOUBLE GIRDER HOIST NE, REEVING: 22

Hoist Dimensions

HOL m	HOL* m	Length code	M1 mm	M2 mm	Min R mm	Max R mm	Weight** kg
16.5	9	E	682	359	1400	2000	1310
22	14.5	F	832	434	1700	2400	1380
29.5	22	G	1022	339	1700	2700	1440
39	31.5	H	1272	364	2000	3100	1560
52	44.5	J	1622	389	2400	3400	1720
63.5	56	K	1922	389	2700	3400	1890
77	69.5	L	2272	414	3100	3400	2090
86.5	79	M	2522	439	3400	3800	2240
98	90.5	N	2822	489	3800	4200	2430

*HOL with drum brake

**Presence of a drum brake will increase weight by 80 kgs.

Motor Dimensions

Motor	P6	P7	P8	A7	S7	S8	SA
MOT (mm)	536	576	711	536	715	763	803
Weight (kg)	85	105	106	71	81	97	120

Trolley Dimensions

C	ØWD	ØBU	BU	BUH	E1	E2	E3	GEA	H3	H4	M3
807	140	63	163	100	488	1834	18	218	757	743	44
RO	TD	TH	WB	W min	W max						
101	90	631	1500	54	84						

D006651_A
090653

Note: All dimensions in mm.

Note: Weight calculated with P6 motor.

Note: Standard rail gauges: 1400, 1700, 2000, 2400, 2700, 3100, 3400, 3800 and 4200.

Note: M2 and weight calculated with min R.

Note: Flangeless wheels available.

Double Girder Hoist NE, REEVING: 22

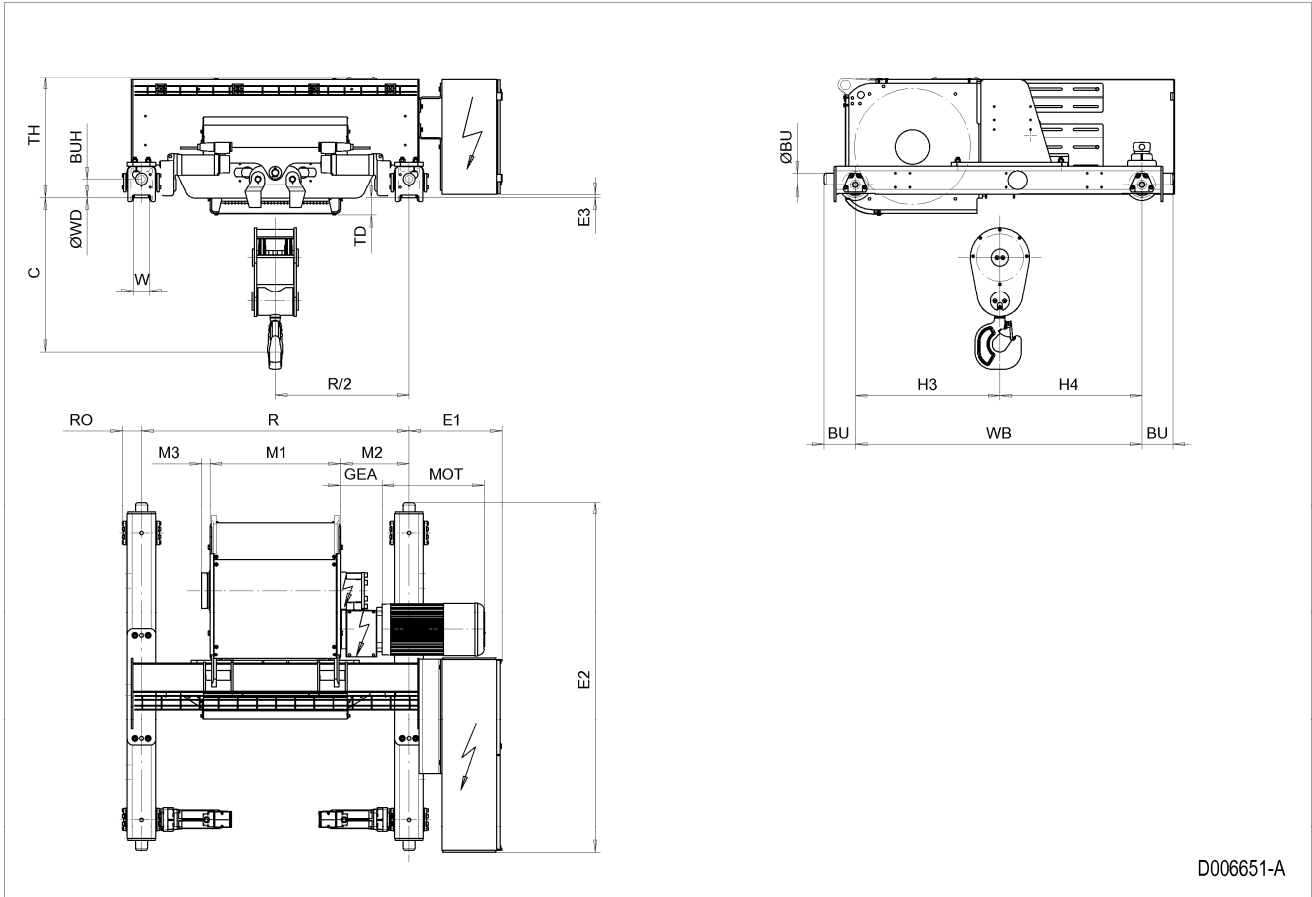

D006651-A

29 DOUBLE GIRDER HOIST NE, REEVING: 24

Hoist Dimensions

HOL m	HOL* m	Length code	M1 mm	M2 mm	Min R mm	Max R mm	Weight** kg
8	4	E	682	359	1400	2000	1380
11	7	F	832	434	1700	2400	1450
14.5	10.5	G	1022	339	1700	2700	1520
19.5	15.5	H	1272	364	2000	3100	1640
26	22	J	1622	389	2400	3400	1800
31.5	27.5	K	1922	389	2700	3400	1970
38.5	34.5	L	2272	414	3100	3400	2170
43	39	M	2522	439	3400	3800	2320
49	45	N	2822	489	3800	4200	2510

*HOL with drum brake

**Presence of a drum brake will increase weight by 80 kgs.

Motor Dimensions

Motor	P6	P7	P8	A7	S7	S8	SA
MOT (mm)	536	576	711	536	715	763	803
Weight (kg)	85	105	106	71	81	97	120

Trolley Dimensions

C	ØWD	ØBU	BU	BUH	E1	E2	E3	GEA	H3	H4	M3
1115	140	63	163	100	488	1834	18	218	757	743	44
RO	TD	TH	WB	W min	W max						
101	90	631	1500	54	84						

D006652_A
090654

Note: All dimensions in mm.

Note: Weight calculated with P6 motor.

Note: Standard rail gauges: 1400, 1700, 2000, 2400, 2700, 3100, 3400, 3800 and 4200.

Note: M2 and weight calculated with the Min R.

Note: Flangeless wheels available.

Double Girder Hoist NE, REEVING: 24

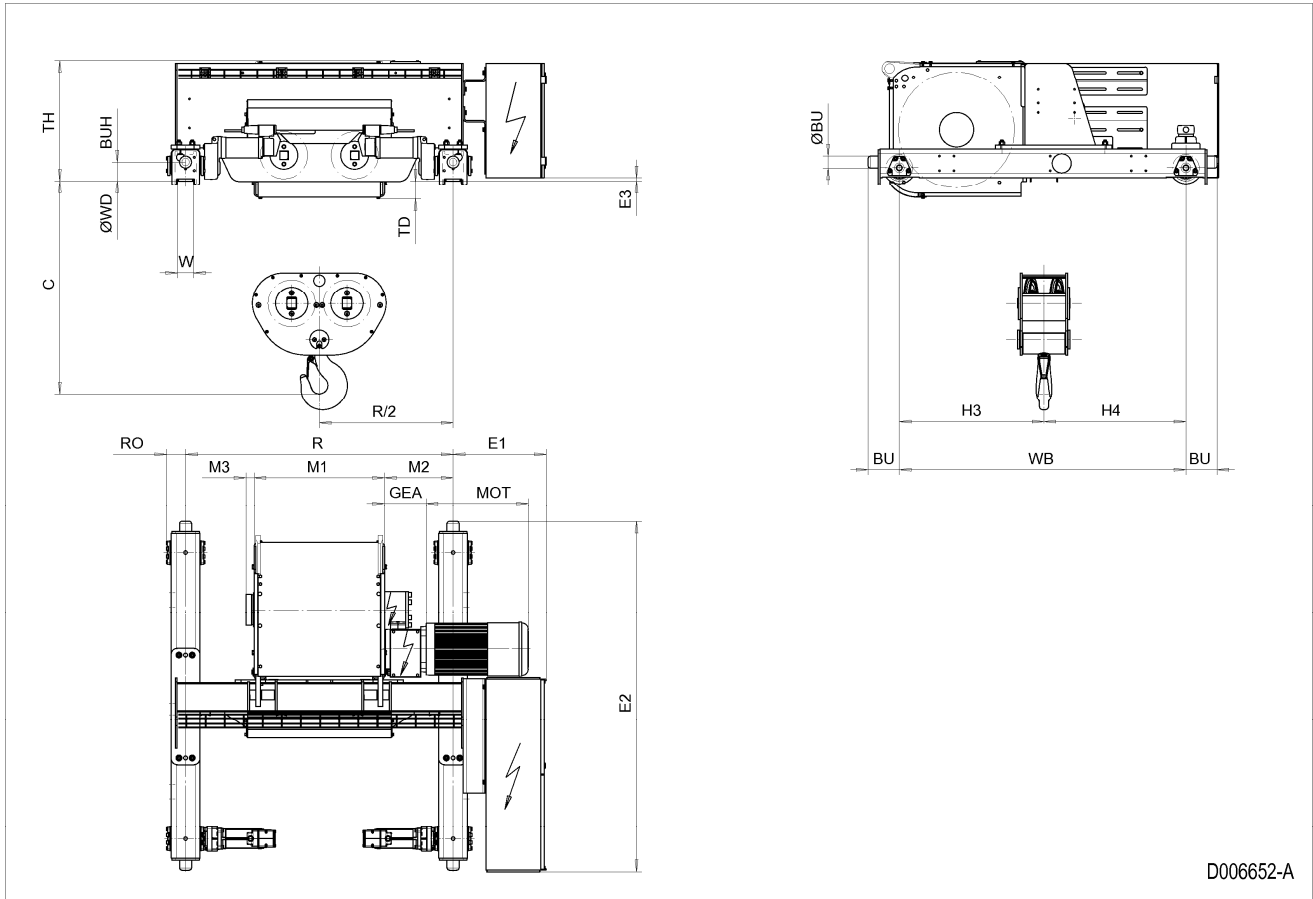

30 DOUBLE GIRDER HOIST NE, REEVING: 26

Hoist Dimensions

HOL m	HOL* m	Length code	M1 mm	M2 mm	Min R mm	Max R mm	Weight** kg
5.5	3	E	682	359	1400	2000	1650
7	4.5	F	832	434	1700	2400	1730
9.5	7	G	1022	339	1700	2700	1800
13	10.5	H	1272	364	2000	3100	1920
17	14.5	J	1622	389	2400	3400	2100
21	18.5	K	1922	389	2700	3400	2280
25.5	23	L	2272	414	3100	3400	2490
28.5	26	M	2522	439	3400	3800	2660
32.5	30	N	2822	489	3800	4200	2870

*HOL with drum brake

**Presence of a drum brake will increase weight by 80 kgs.

Motor Dimensions

Motor	P6	P7	P8	A7	S7	S8	SA
MOT (mm)	536	576	711	536	715	763	803
Weight (kg)	85	105	106	71	81	97	120

Trolley Dimensions

C	ØWD	ØBU	BU	BUH	E1	E2	E3	GEA	H3	H4	M3
1154	200	80	226	100	488	1852	80	218	712	698	44
RO	TD	TH	WB	W min	W max						
122	28	693	1410	54	99						

D006653_A
090655

Note: All dimensions in mm.

Note: Weight calculated with P6 motor.

Note: Standard rail gauges: 1400, 1700, 2000, 2400, 2700, 3100, 3400, 3800 and 4200.

Note: M2 and weight calculated with the Min R.

Note: Flangeless wheels available.

Double Girder Hoist NE, REEVING: 26

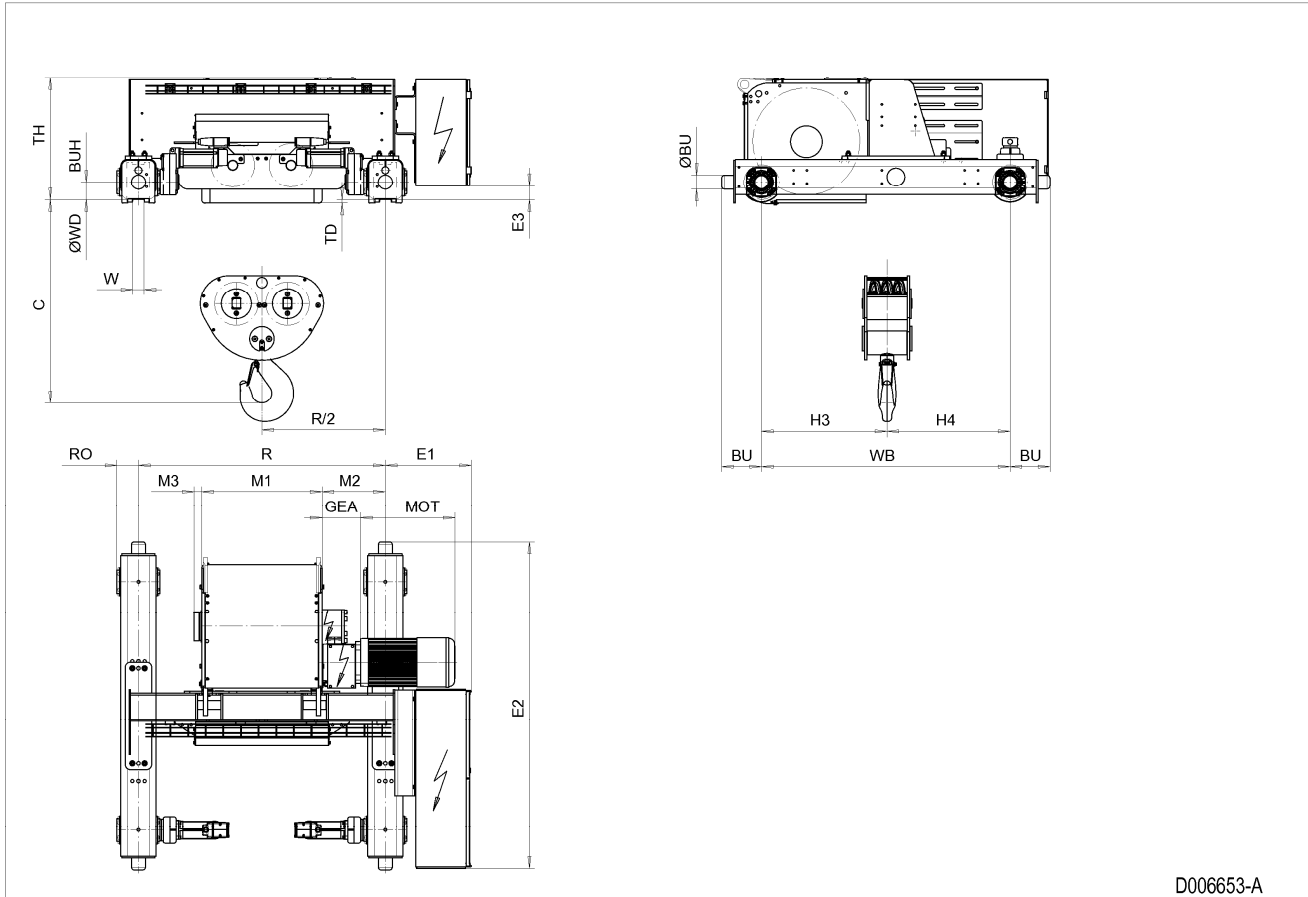

D006653-A

31 DOUBLE GIRDER HOIST NE, REEVING: 28

Hoist Dimensions

HOL m	HOL* m	Length code	M1 mm	M2 mm	Min R mm	Max R mm	Weight** kg
5.5	3.5	F	832	434	1700	2400	1850
7	5	G	1022	339	1700	2700	1920
9.5	7.5	H	1272	364	2000	3100	2050
13	11	J	1622	389	2400	3400	2230
15.5	13.5	K	1922	389	2700	3400	2400
19	17	L	2272	414	3100	3400	2620
21.5	19.5	M	2522	439	3400	3800	2790
24.5	22.5	N	2822	489	3800	4200	3010

*HOL with drum brake

**Presence of a drum brake will increase weight by 80 kgs.

Motor Dimensions

Motor	P6	P7	P8	A7	S7	S8	SA
MOT (mm)	536	576	711	536	715	763	803
Weight (kg)	85	105	106	71	81	97	120

Trolley Dimensions

C	ØWD	ØBU	BU	BUH	E1	E2	E3	GEA	H3	H4	M3
1280	200	80	226	100	488	1852	80	218	712	698	44
RO	TD	TH	WB	W min	W max						
122	28	693	1410	54	99						

D006654_A
090656

Note: All dimensions in mm.

Note: Weight calculated with P6 motor.

Note: Standard rail gauges: 1700, 2000, 2400, 2700, 3100, 3400, 3800 and 4200.

Note: M2 and weight calculated with the Min R.

Note: Flangeless wheels available.

Double Girder Hoist NE, REEVING: 28

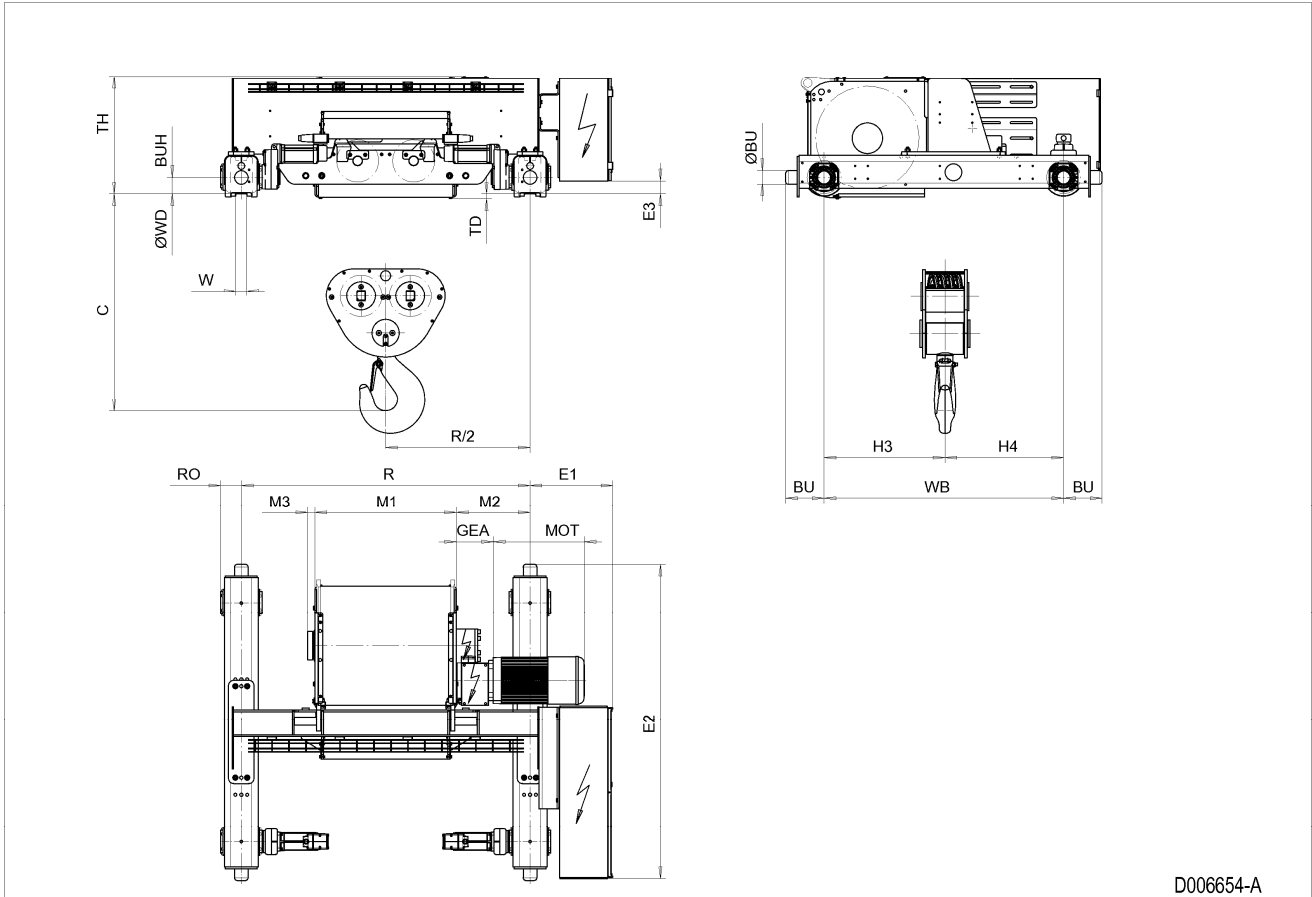

D006654-A

32 DOUBLE GIRDER HOIST NF, REEVING: 22

Hoist Dimensions

HOL m	HOL* m	Length code	M1 mm	M2 mm	Min R mm	Max R mm	Weight** kg
15.5	9	F	832	434	1700	2400	1800
20.5	14	G	1022	339	1700	2700	1950
27.5	21	H	1272	214	2000	3100	2080
37.5	31	J	1622	389	2400	3100	2270
46	39.5	K	1922	389	2700	3100	2430
55.5	49	L	2272	414	3100	3400	2620
62.5	56	M	2522	439	3400	3800	2780
71	64.5	N	2822	489	3800	4200	2970

*HOL with drum brake

**Presence of a drum brake will increase weight by 80 kgs.

Motor Dimensions

Motor	P6	P7	A7	S7	S8	SA
MOT (mm)	536	576	536	715	763	803
Weight (kg)	85	105	71	81	97	120

Trolley Dimensions

C	ØWD	ØBU	BU	BUH	E1	E2	E3	GEA	H3	H4	M3
960	200	80	226	100	488	1826	80	218	712	698	44
RO	TD	TH	WB	W min	W max						
122	30	693	1410	54	99						

D006655_A
090657

Note: All dimensions in mm.

Note: Weight calculated with P6 motor.

Note: Standard rail gauges: 1700, 2000, 2400, 2700, 3100, 3400, 3800 and 4200.

Note: M2 and weight calculated with min R.

Note: Flangeless wheels available.

Double Girder Hoist NF, REEVING: 22

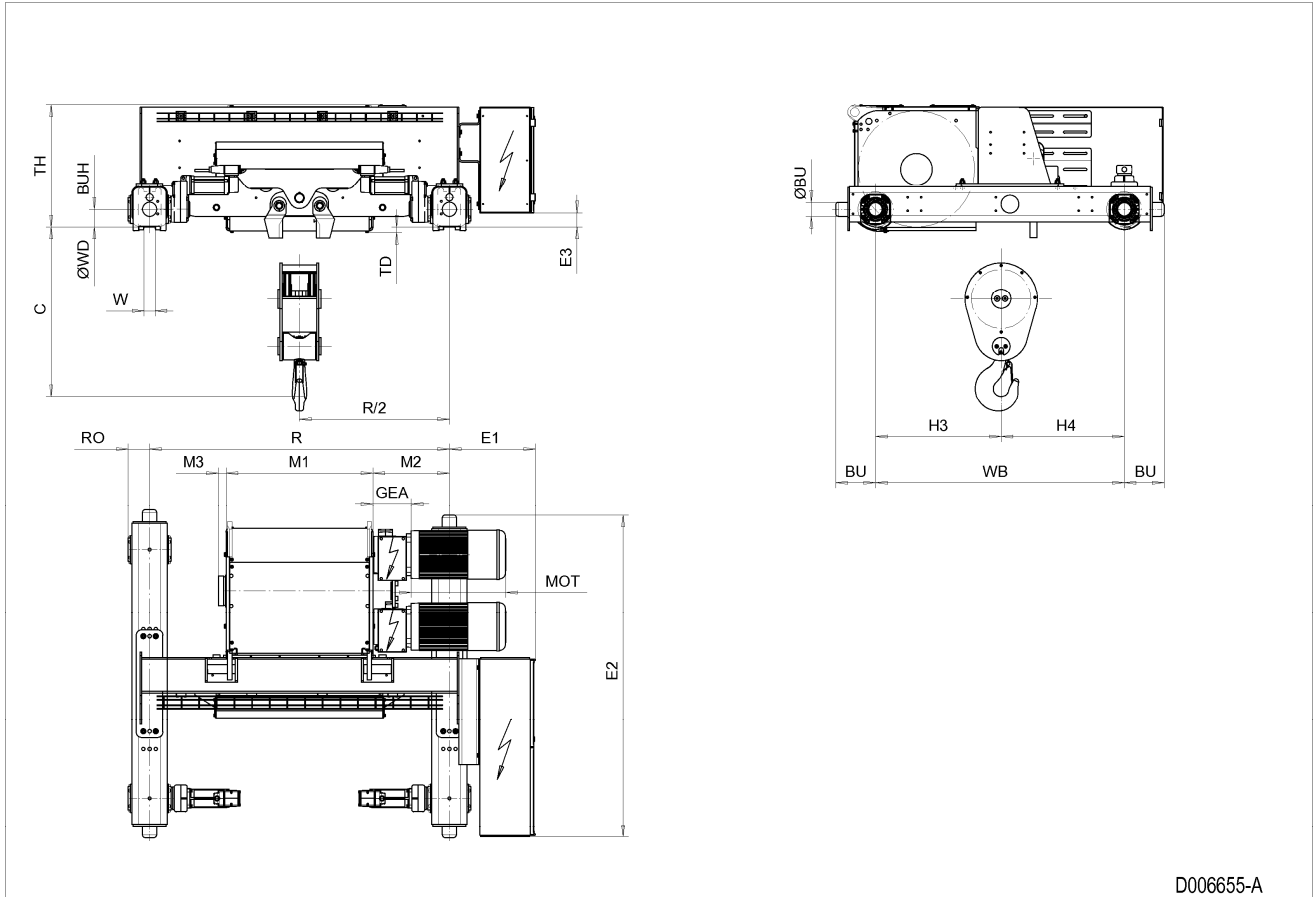

D006655-A

33 DOUBLE GIRDER HOIST NF, REEVING: 24

Hoist Dimensions

HOL m	HOL* m	Length code	M1 mm	M2 mm	Min R mm	Max R mm	Weight** kg
7.5	4	F	832	434	1700	2400	2040
10	6.5	G	1022	339	1700	2700	2200
13.5	10	H	1272	214	2000	3100	2330
18.5	15	J	1622	389	2400	3100	2530
23	19.5	K	1922	389	2700	3100	2680
27.5	24	L	2272	414	3100	3400	2880
31	27.5	M	2522	439	3400	3800	3030
35.5	32	N	2822	489	3800	4200	3230

*HOL with drum brake

**Presence of a drum brake will increase weight by 80 kgs.

Motor Dimensions

Motor	P6	P7	A7	S7	S8	SA
MOT (mm)	536	576	536	715	763	803
Weight (kg)	85	105	71	81	97	120

Trolley Dimensions

C	ØWD	ØBU	BU	BUH	E1	E2	E3	GEA	H3	H4	M3
1305	200	80	226	100	488	1856	80	218	712	698	44
RO	TD	TH	WB	W min	W max						
122	30	693	1410	54	99						

D006656_A
090658

Note: All dimensions in mm.

Note: Weight calculated with P6 motor.

Note: Standard rail gauges: 1700, 2000, 2400, 2700, 3100, 3400, 3800 and 4200.

Note: M2 and weight calculated with min R.

Note: Flangeless wheels available.

Double Girder Hoist NF, REEVING: 24

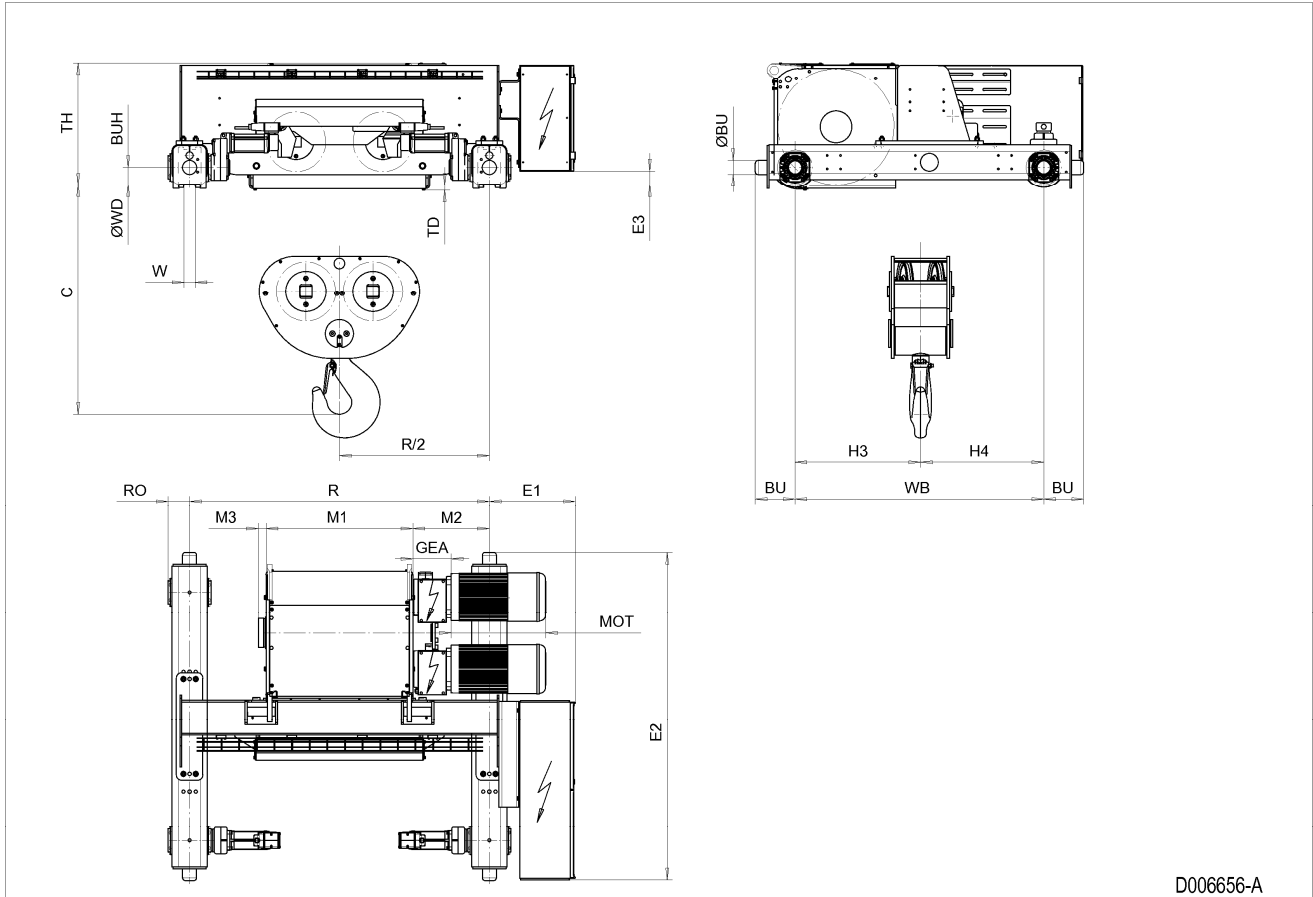

D006656-A

34 DOUBLE GIRDER HOIST NF, REEVING: 26

Hoist Dimensions

HOL m	HOL* m	Length code	M1 mm	M2 mm	Min R mm	Max R mm	Weight** kg
5	2.5	F	832	434	1700	2400	2530
6.5	4	G	1022	339	1700	2700	2690
9	6.5	H	1272	214	2000	3100	2830
12.5	10	J	1622	389	2400	3100	3070
15	12.5	K	1922	389	2700	3100	3310
18.5	16	L	2272	414	3100	3400	3580
20.5	18	M	2522	439	3400	3800	3790
23.5	21	N	2822	489	3800	4200	4040

*HOL with drum brake

**Presence of a drum brake will increase weight by 80 kgs.

Motor Dimensions

Motor	P6	P7	A7	S7	S8	SA
MOT (mm)	536	576	536	715	763	803
Weight (kg)	85	105	71	81	97	120

Trolley Dimensions

C	ØWD	ØBU	BU	BUH	E1	E2	E3	GEA	H3	H4	M3
1354	250	100	262	150	488	1868	107	218	687	653	44
RO	TD	TH	WB	W min	W max						
129	20	720	1340	54	99						

D006657_A
090659

Note: All dimensions in mm.

Note: Weight calculated with P6 motor.

Note: Standard rail gauges: 1700, 2000, 2400, 2700, 3100, 3400, 3800 and 4200.

Note: M2 and weight calculated with min R.

Note: Flangeless wheels available.

Double Girder Hoist NF, REEVING: 26

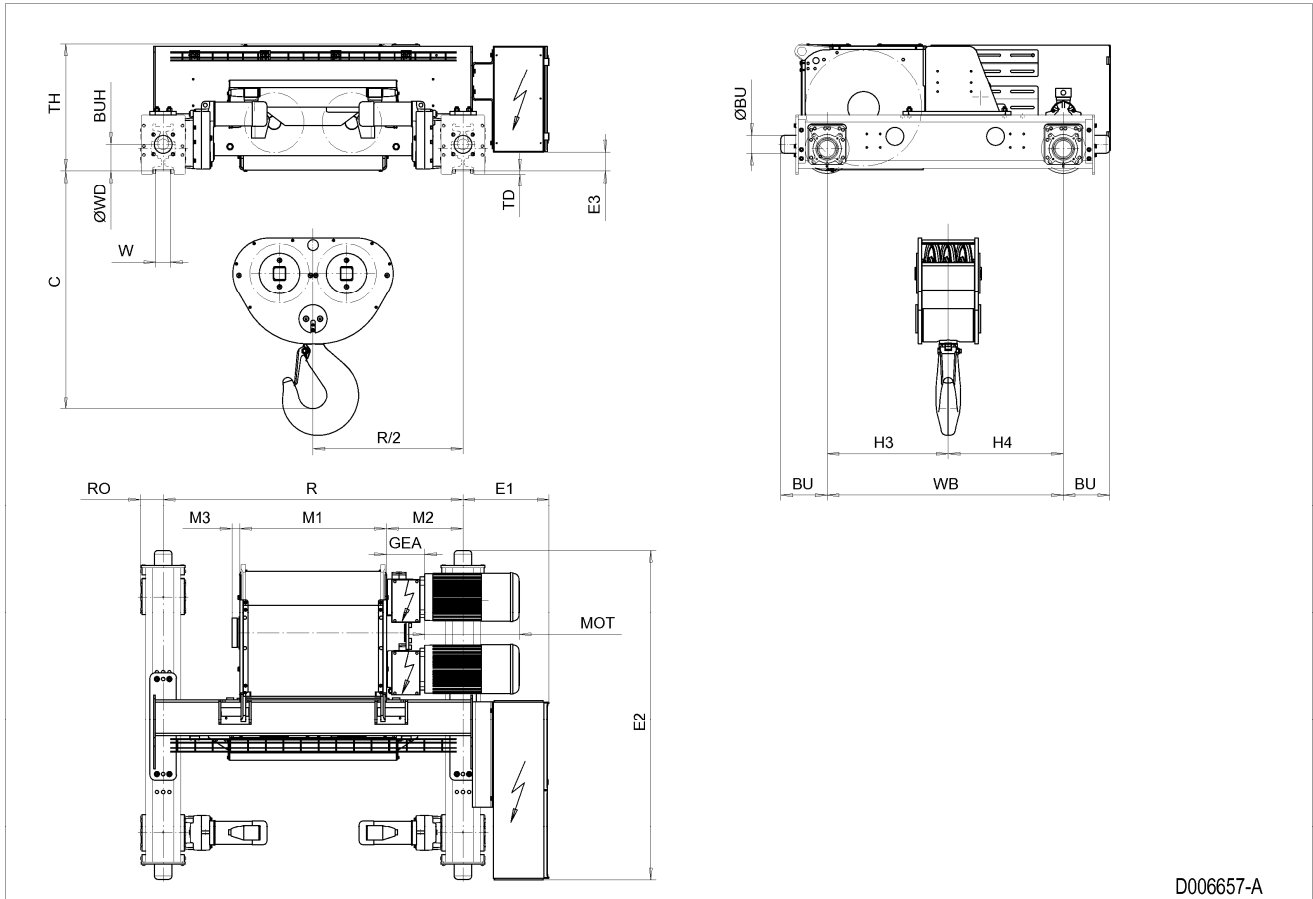

D006657-A

35 DOUBLE GIRDER HOIST NF, REEVING: 28

Hoist Dimensions

HOL m	HOL* m	Length code	M1 mm	M2 mm	Min R mm	Max R mm	Weight** kg
6.5	4.5	H	1272	364	2400	3100	3380
9	7	J	1622	389	2400	3100	3610
11	9	K	1922	389	2700	3100	3860
13.5	11.5	L	2272	414	3100	3400	4140
15.5	13.5	M	2522	439	3400	3800	4330
17.5	15.5	N	2822	489	3800	4200	4590

*HOL with drum brake

**Presence of a drum brake will increase weight by 80 kgs.

Motor Dimensions

Motor	P6	P7	A7	S7	S8	SA
MOT (mm)	536	576	536	715	763	803
Weight (kg)	85	105	71	81	97	120

Trolley Dimensions

C	ØWD	ØBU	BU	BUH	E1	E2	E3	GEA	H3	H4	M3
1410	250	100	262	150	488	1868	142	218	687	733	44
RO	TD	TH	WB	W min	W max						
173	20	755	1420	54	99						

D006658_A
090660

Note: All dimensions in mm.

Note: Weight calculated with P6 motor.

Note: Standard rail gauges: 2400, 2700, 3100, 3400, 3800 and 4200.

Note: M2 and weight calculated with min R.

Note: Flangeless wheels available.

Double Girder Hoist NF, REEVING: 28

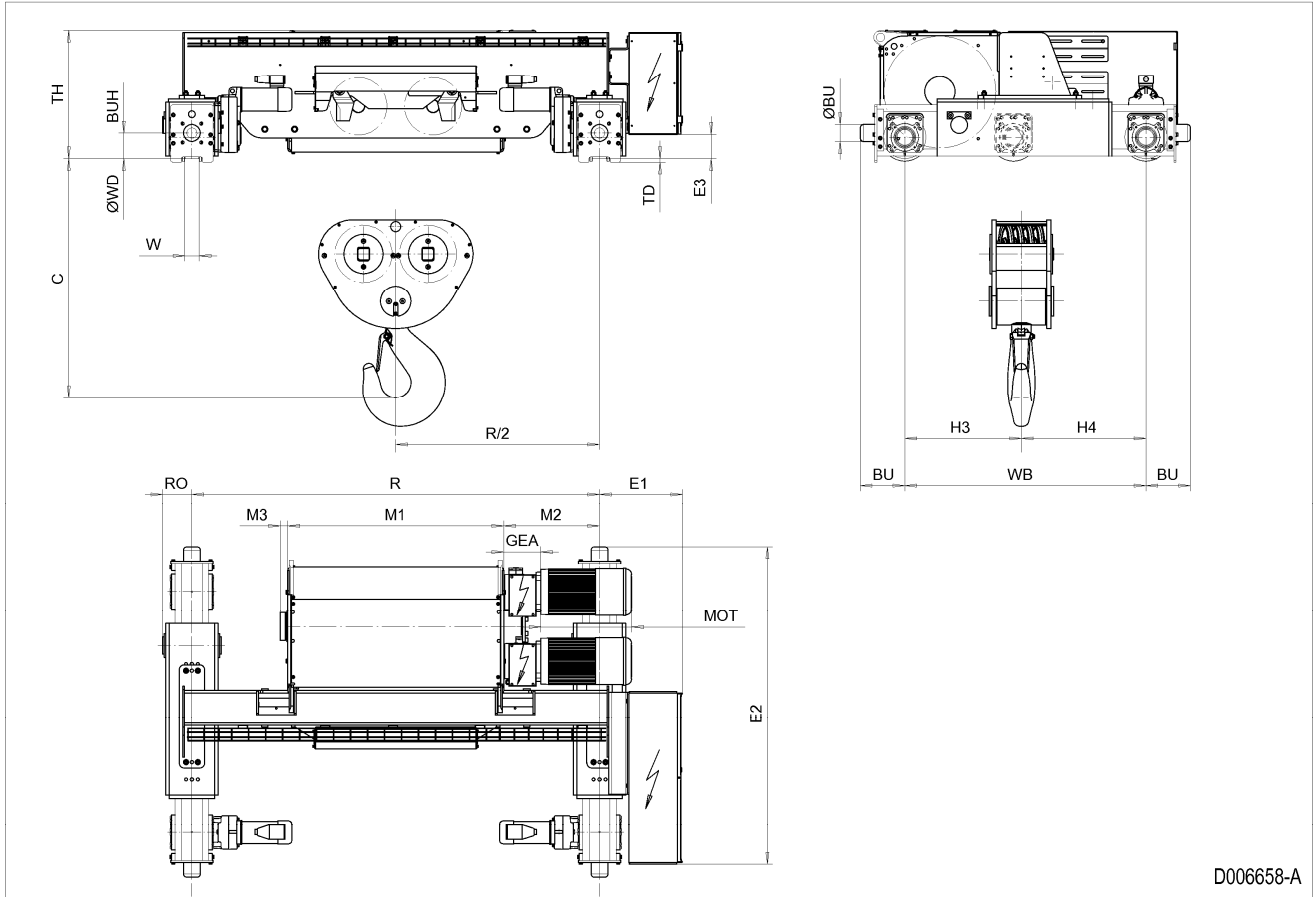

D006658-A

DOUBLE GIRDER TROLLEY, HIGH

36 HIGH DOUBLE GIRDER HOIST NB, REEVING: 02

Hoist dimensions

HOL m	Length code	M1 mm	M2 mm	H1 mm	H2 mm	Min R mm	Weight kg
12	A	326	274	369	90	900	210
19	C	456	274	369	144	900	220

Motor dimensions

Motor	P1	P2	P3	A3	S3
MOT (mm)	386	446	476	446	526
Weight (kg)	21	31	35	32	28

Trolley dimensions

C	ØBU	BU	BUH	E1	E2	E3	GEA	H3	WB	ØWD	W min
185	63	138	90	327	714	15	110	398	820	90	50
W max	RO	TD	TH								
70	83	15	403								

D002074_A
062128

Note: All dimensions in mm.

Note: H1, M2 and weight calculated with P1 motor and Min R.

Note: Min R with second brake.

Note: Standard rail gauges: 900, 1200, 1400, 1700 and 2000.

Note: Flangeless wheels available.

High Double Girder Hoist NB, REEVING: 02

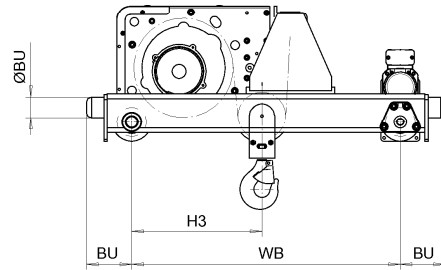
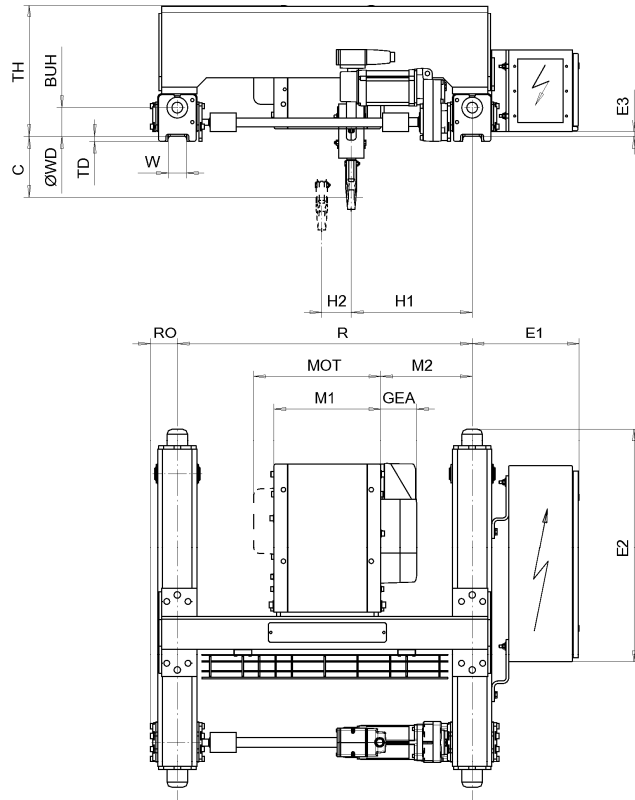

D002074-A

37 HIGH DOUBLE GIRDER HOIST NB, REEVING: 04

Hoist dimensions

HOL m	Length code	M1 mm	M2 mm	H1 mm	H2 mm	Min R mm	Weight kg
6	A	326	274	424	45	900	210
9.5	C	456	274	424	72	900	220

Motor dimensions

Motor	P1	P2	P3	A3	S3
MOT (mm)	386	446	476	446	526
Weight (kg)	21	31	35	32	28

Trolley dimensions

C	ØBU	BU	BUH	E1	E2	E3	GEA	WB	ØWD	W min	W max
135	63	138	90	327	714	15	110	820	90	50	70
RO	TD	TH									
83	15	403									

D002079_A
028596

Note: All dimensions in mm.

Note: H1, M2 and weight calculated with P1 motor and Min R.

Note: Min R with second brake.

Note: Standard rail gauges: 900, 1200, 1400, 1700 and 2000.

Note: Flangeless wheels available.

High Double Girder Hoist NB, REEVING: 04

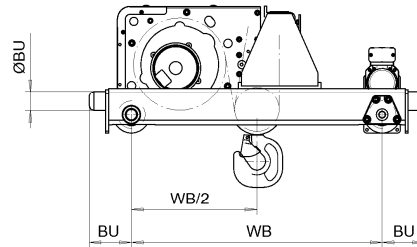
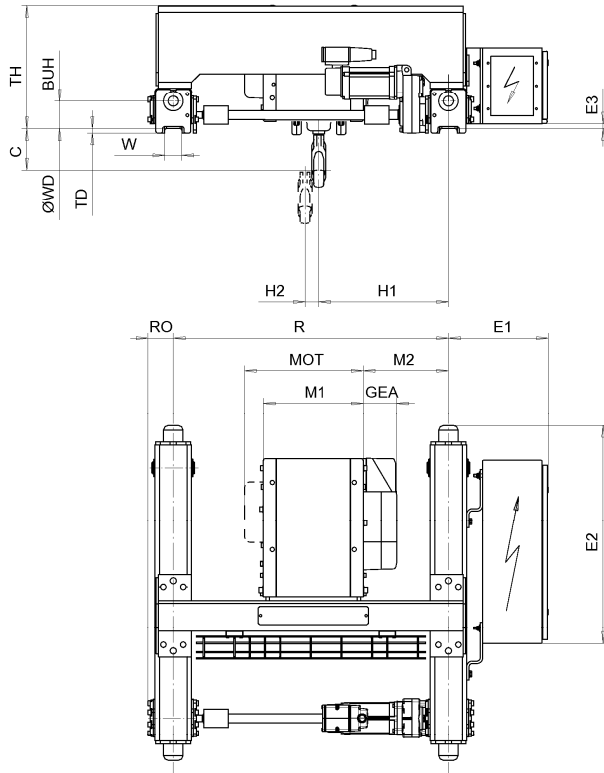

D002079-A

38 HIGH DOUBLE GIRDER HOIST NC, REEVING: 02

Hoist dimensions

HOL m	Length code	M1 mm	M2 mm	H1 mm	H2 mm	Min R mm	Weight kg
12	B	356	217	308	95	900	321
18	C	456	217	308	144	900	331
24	D	556	217	308	193	900	346
30	E	676	367	458	252	1200	367

Motor dimensions

Motor	P3	P4	A3	S3	S5
MOT (mm)	473	574	443	523	602
Weight (kg)	35	53	32	28	53

Trolley dimensions

C	ØBU	BU	BUH	E1	E2	E3	GEA	H3	WB	ØWD	W min
90	63	138	90	327	758	12	116	482	1010	90	50
W max	RO	TD	TH								
70	83	15	575								

D002229_A
062229

Note: All dimensions in mm.

Note: H1, M2 and weight calculated with P3 motor and Min R.

Note: Motor S5 is unavailable for load class 3200 kg.

Note: Min R with service platform and second brake.

Note: Standard rail gauges: 900, 1200, 1400, 1700 and 2000.

Note: Flangeless wheels available.

High Double Girder Hoist NC, REEVING: 02

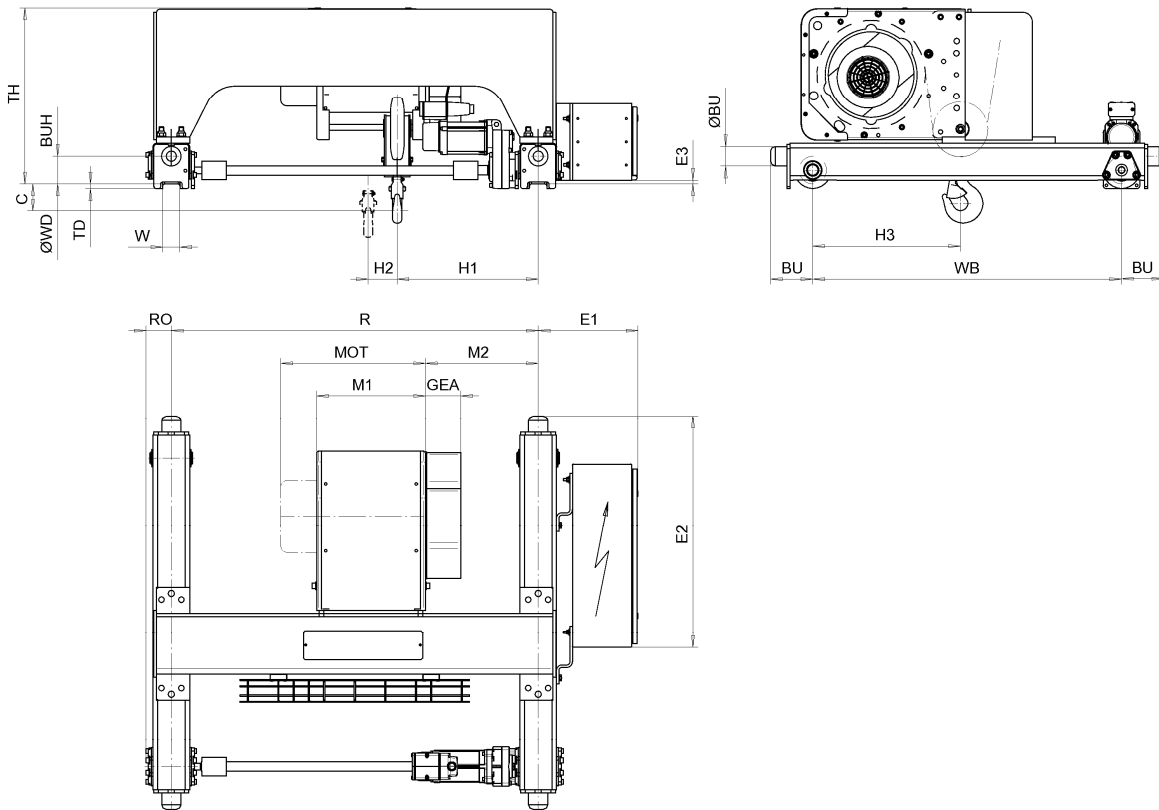

D002229-A

39 HIGH DOUBLE GIRDER HOIST NC, REEVING: 04

Hoist dimensions

HOL m	Length code	M1 mm	M2 mm	H1 mm	H2 mm	Min R mm	Weight kg
6	B	356	217	386	49	900	325
9	C	456	217	386	74	900	335
12	D	556	217	386	99	900	355
15	E	676	367	536	129	1200	375

Motor dimensions

Motor	P3	P4	A3	S3	S5
MOT (mm)	473	574	443	523	602
Weight (kg)	35	53	32	28	53

Trolley dimensions

C1	C2	ØBU	BU	BUH	E1	E2	E3	GEA	WB	ØWD	W min
80	97	63	138	90	327	758	12	116	1010	90	50
W max	RO	TD	TH								
70	83	15	575								

D002230_A
062231

Note: All dimensions in mm.

Note: H1, M2 and weight calculated with P3 motor and Min R.

Note: Motor S5 is unavailable for load class 6300 kg.

Note: Min R with service platform and second brake.

Note: Standard rail gauges: 900, 1200, 1400, 1700 and 2000.

Note: Flangeless wheels available.

High Double Girder Hoist NC, REEVING: 04

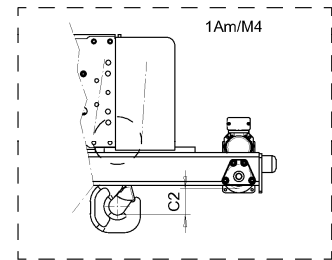
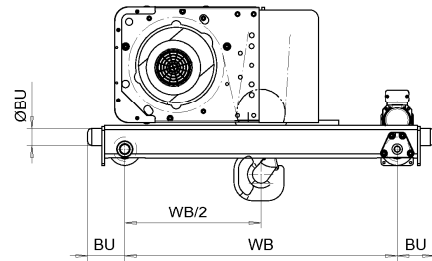
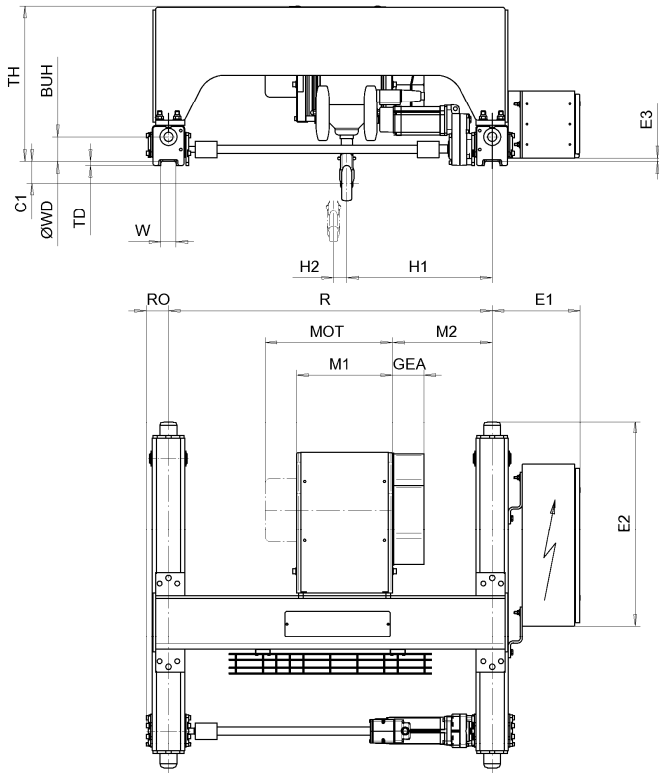

D002230-A

40 HIGH DOUBLE GIRDER HOIST ND, REEVING: 02

Hoist dimensions

HOL m	Length code	M1 mm	M2 mm	H1 mm	H2 mm	Min R mm	Weight kg
18	D	558	303	458	176	1200	665
24	E	678	303	458	235	1200	690
32	F	828	266	421	309	1200	715
40	G	1018	516	671	403	1700	795

Motor dimensions

Motor	P5	P6	P7	A5	S5	S7
MOT (mm)	578	578	618	498	606	757
Weight (kg)	58	85	105	45	53	81

Trolley dimensions

C	ØBU	BU	BUH	E1	E2	E3	GEA	H3	WB	ØWD	W min
211	63	148	100	382	1028	15	143	552	1080	110	52
W max	RO	TD	TH								
87	98	15	692								

D002238_A
062235

Note: All dimensions in mm.

Note: H1, M2 and weight calculated with P5 motor and Min R.

Note: Motor S7 is unavailable for load class 6300 kg.

Note: Min R with service platform and second brake.

Note: Standard rail gauges: 1200, 1400, 1700 and 2000.

Note: Flangeless wheels available.

High Double Girder Hoist ND, REEVING: 02

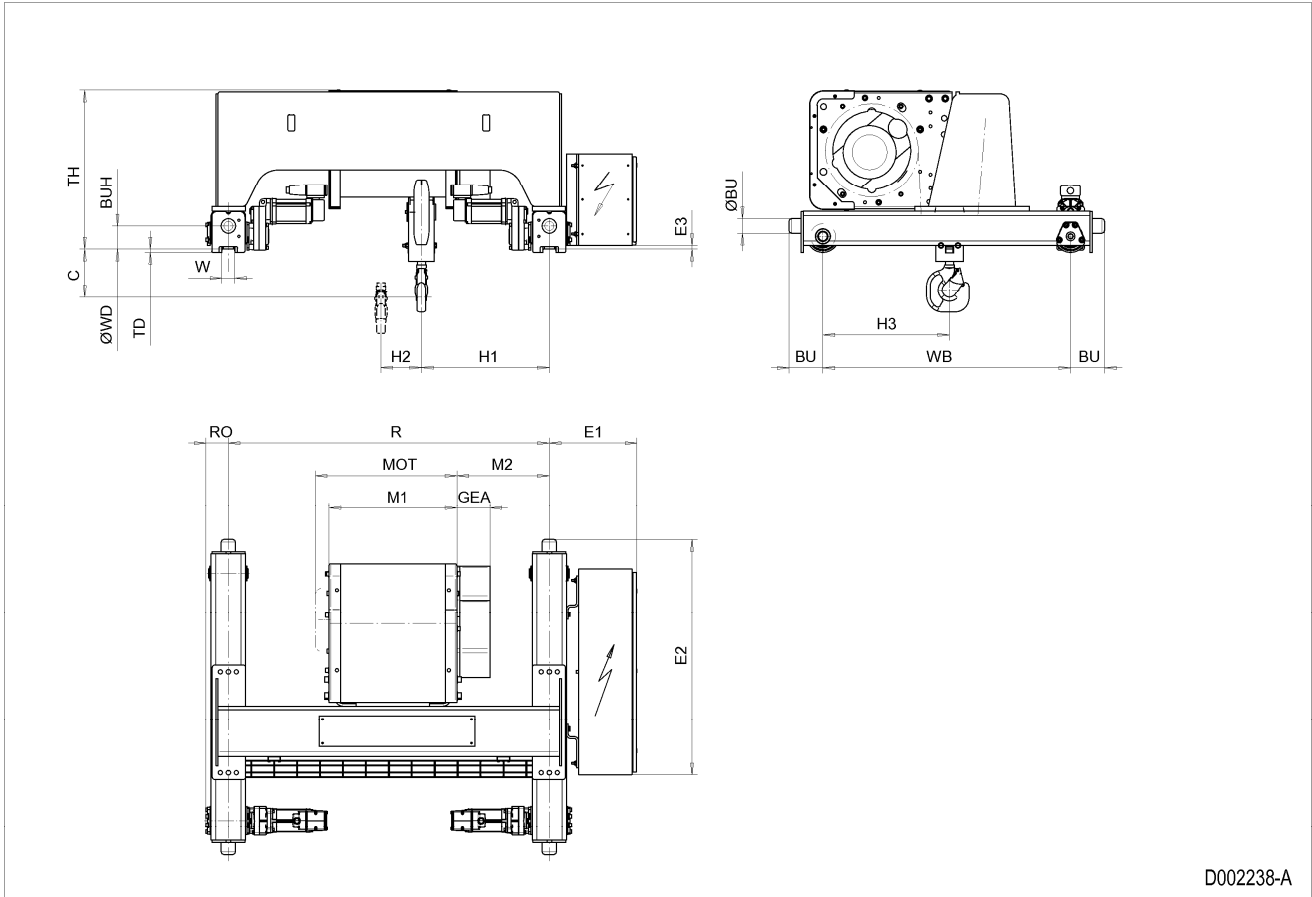

D002238-A

41 HIGH DOUBLE GIRDER HOIST ND, REEVING: 04

Hoist dimensions

HOL m	Length code	M1 mm	M2 mm	H1 mm	H2 mm	Min R mm	Weight kg
9	D	558	303	540	88	1200	685
12	E	678	303	540	118	1200	710
16	F	828	266	503	156	1200	735
20	G	1018	516	753	204	1700	815

Motor dimensions

Motor	P5	P6	P7	A5	S5	S7
MOT (mm)	578	578	618	498	606	757
Weight (kg)	58	85	105	45	53	81

Trolley dimensions

C1	C2	ØBU	BU	BUH	E1	E2	E3	GEA	H3	WB	ØWD
155	210	63	148	100	382	1028	15	143	585	1080	110
W min	W max	RO	TD	TH							
52	87	98	15	692							

D002240_A
062246

Note: All dimensions in mm.

Note: H1, M2 and weight calculated with P5 motor and Min R.

Note: Motor S7 is unavailable for load class 12500 kg.

Note: Min R with service platform and second brake.

Note: Standard rail gauges: 1200, 1400, 1700 and 2000.

Note: Flangeless wheels available.

High Double Girder Hoist ND, REEVING: 04

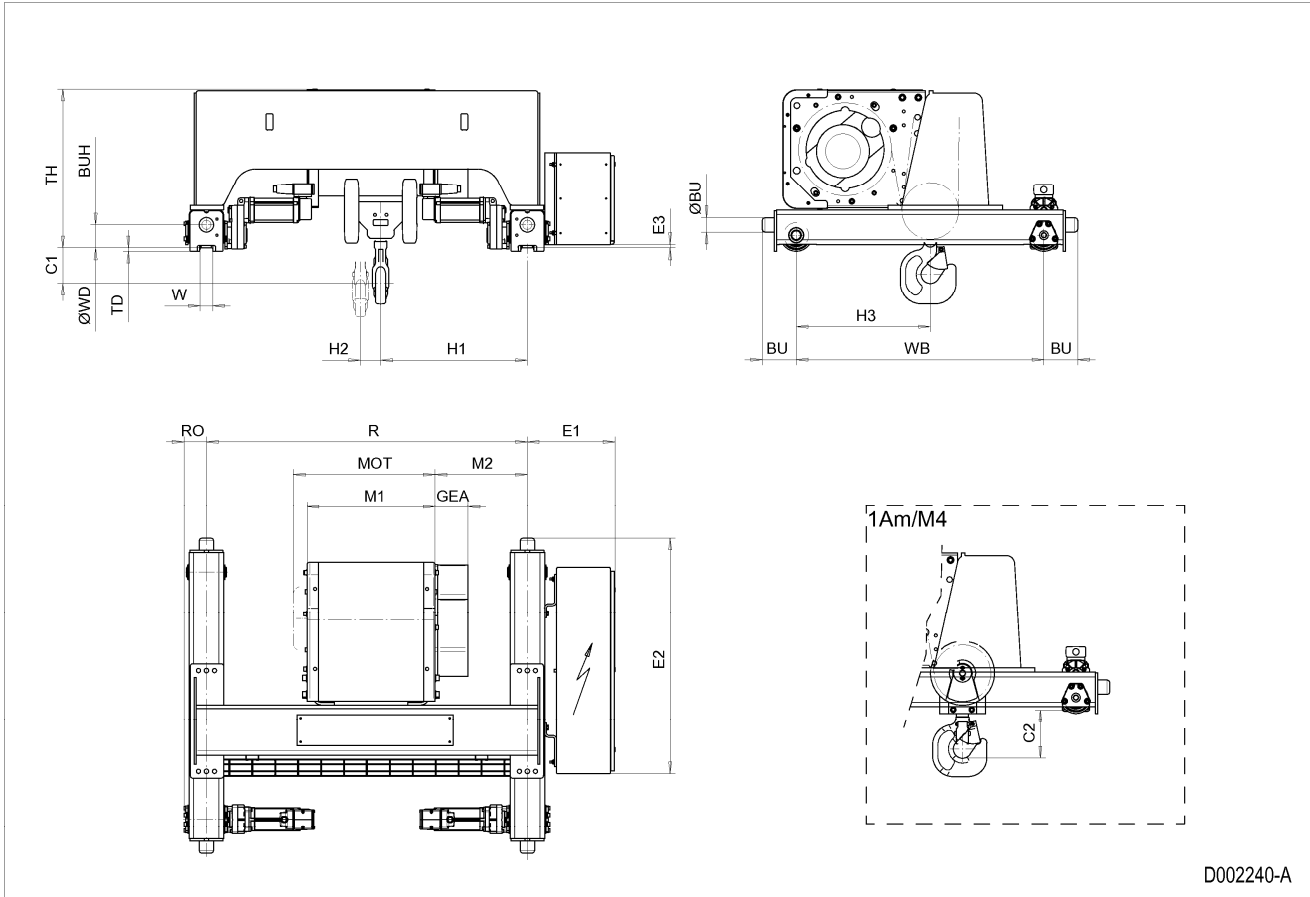

42 HIGH DOUBLE GIRDER HOIST ND, REEVING: 06

Hoist dimensions

HOL m	Length code	M1 mm	M2 mm	H1 mm	H2 mm	Min R mm	Weight kg
6	D	558	548	515	53	1200	765
8	E	678	628	595	78	1400	800
10	F	828	778	745	98	1700	850
13	G	1018	888	855	132	2000	905

Motor dimensions

Motor	P5	P6	P7	A5	S5	S7
MOT (mm)	578	578	618	498	606	757
Weight (kg)	58	85	105	45	53	81

Trolley dimensions

C	ØBU	BU	BUH	E1	E2	E3	GEA	WB	ØWD	W min	W max
525	63	163	100	382	1343	18	143	1080	140	54	84
RO	TD	TH									
98	20	695									

D007196_A
124517

Note: All dimensions in mm.

Note: H1, M2 and weight calculated with P5 motor and Min R.

Note: Min R with service platform and second brake.

Note: Standard rail gauges: 1200, 1400, 1700, 2000 and 2400.

Note: Flangeless wheels available.

High Double Girder Hoist ND, REEVING: 06

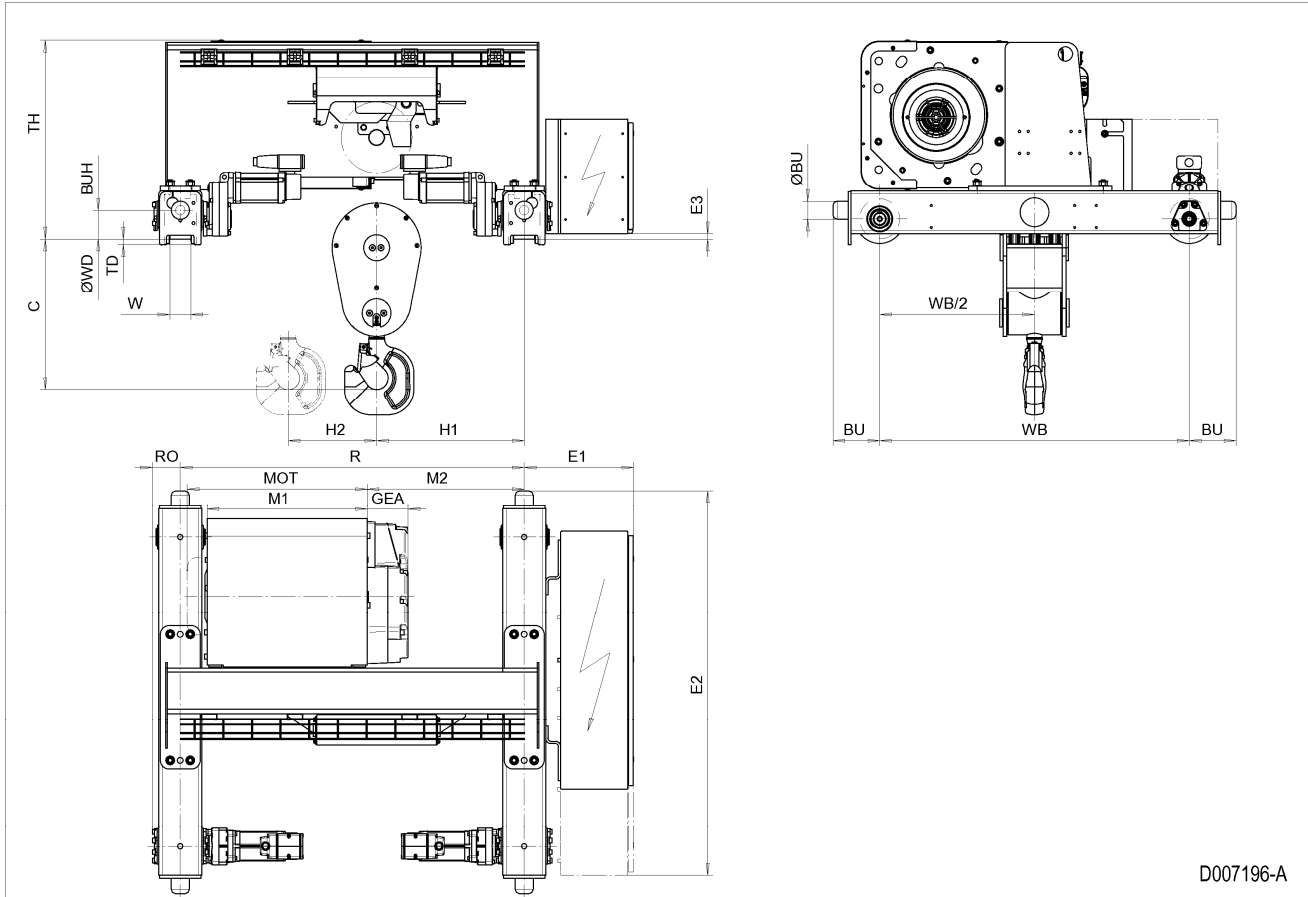

D007196-A

43 HIGH DOUBLE GIRDER HOIST ND, REEVING: 08

Hoist dimensions

HOL m	Length code	M1 mm	M2 mm	H1 mm	H2 mm	Min R mm	Weight kg
4.5	D	558	548	515	44	1200	780
6	E	678	628	595	53	1400	815
8	F	828	778	745	76	1700	865
10	G	1018	888	855	98	2000	915

Motor dimensions

Motor	P5	P6	P7	A5	S5	S7
MOT (mm)	578	578	618	498	606	757
Weight (kg)	58	85	105	45	53	81

Trolley dimensions

C	ØBU	BU	BUH	E1	E2	E3	GEA	WB	ØWD	W min	W max
525	63	163	100	382	1343	18	143	1080	140	54	84
RO	TD	TH									
98	20	695									

D007197_A
124518

Note: All dimensions in mm.

Note: H1, M2 and weight calculated with P5 motor and Min R.

Note: Min R with service platform and second brake.

Note: Standard rail gauges: 1200, 1400, 1700, 2000 and 2400.

Note: Flangeless wheels available.

High Double Girder Hoist ND, REEVING: 08

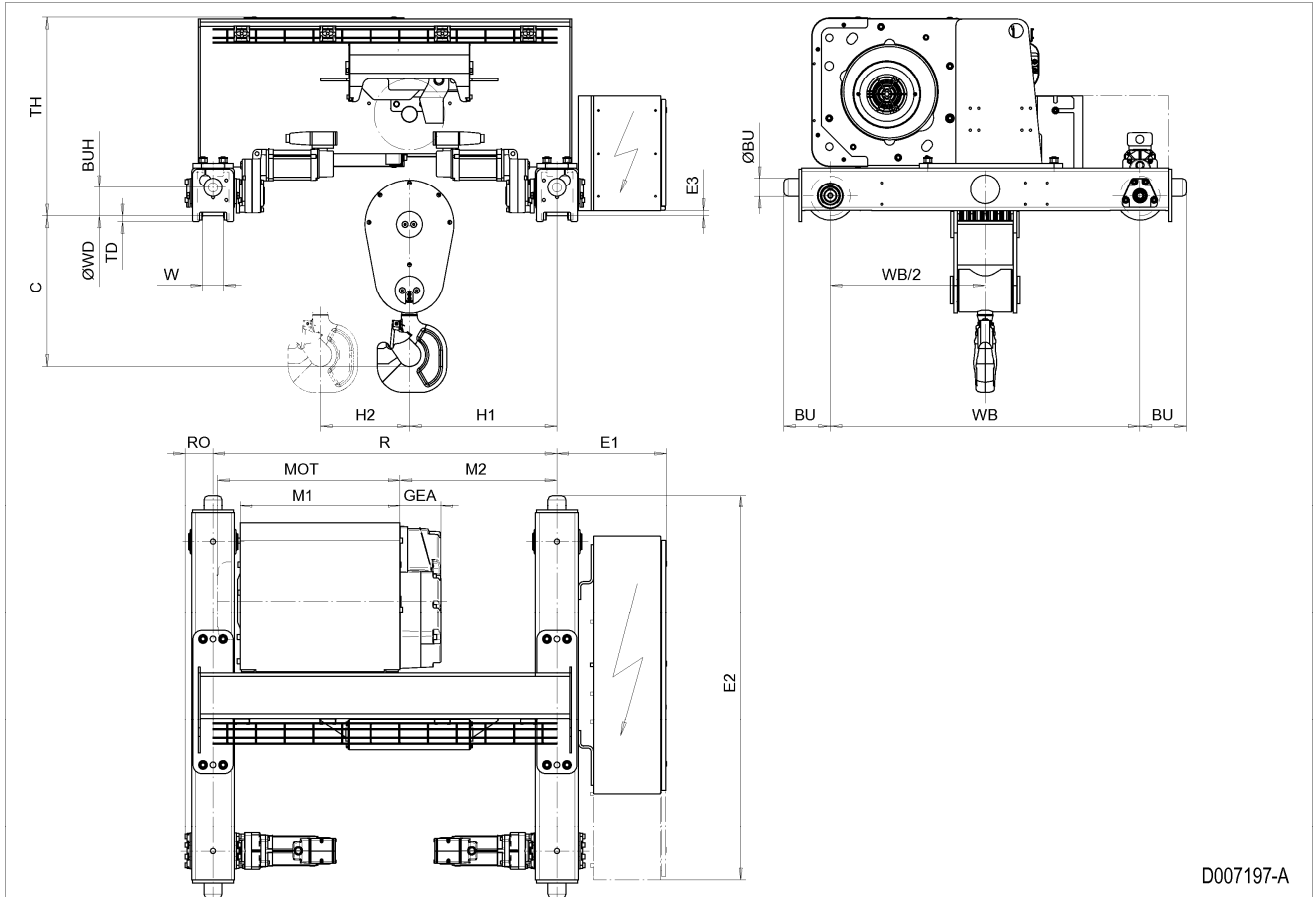

D007197-A

44 HIGH DOUBLE GIRDER HOIST ND, REEVING: 22

Hoist dimensions

HOL m	Length code	M1 mm	M2 mm	BRA mm	Min R mm	Weight kg
8.5	D	558	321	-	1200	675
13	E	678	261	-	1200	695
18	F	828	286	-	1400	735
25	G	1018	341	-	1700	785
33.5	H	1268	216	128	1700	840
46	J	1618	424	128	2400	950

Motor dimensions

Motor	P5	P6	P7	A5	S5	S7
MOT (mm)	578	578	618	498	606	757
Weight (kg)	58	85	105	45	53	81

Trolley dimensions

C	ØBU	BU	BUH	E1	E2	E3	GEA	H3	WB	ØWD	W min
355	63	148	100	382	1328	15	143	585	1080	110	52
W max	RO	TD	TH								
87	98	20	692								

D007182_A
124426

Note: All dimensions in mm.

Note: M2 and weight calculated with P5 motor and Min R.

Note: Min R with service platform and second brake.

Note: Standard rail gauges: 1200, 1400, 1700, 2000 and 2400.

Note: Gear brake as standard brake for drum lengths H and J.

Note: Flangeless wheels available.

High Double Girder Hoist ND, REEVING: 22

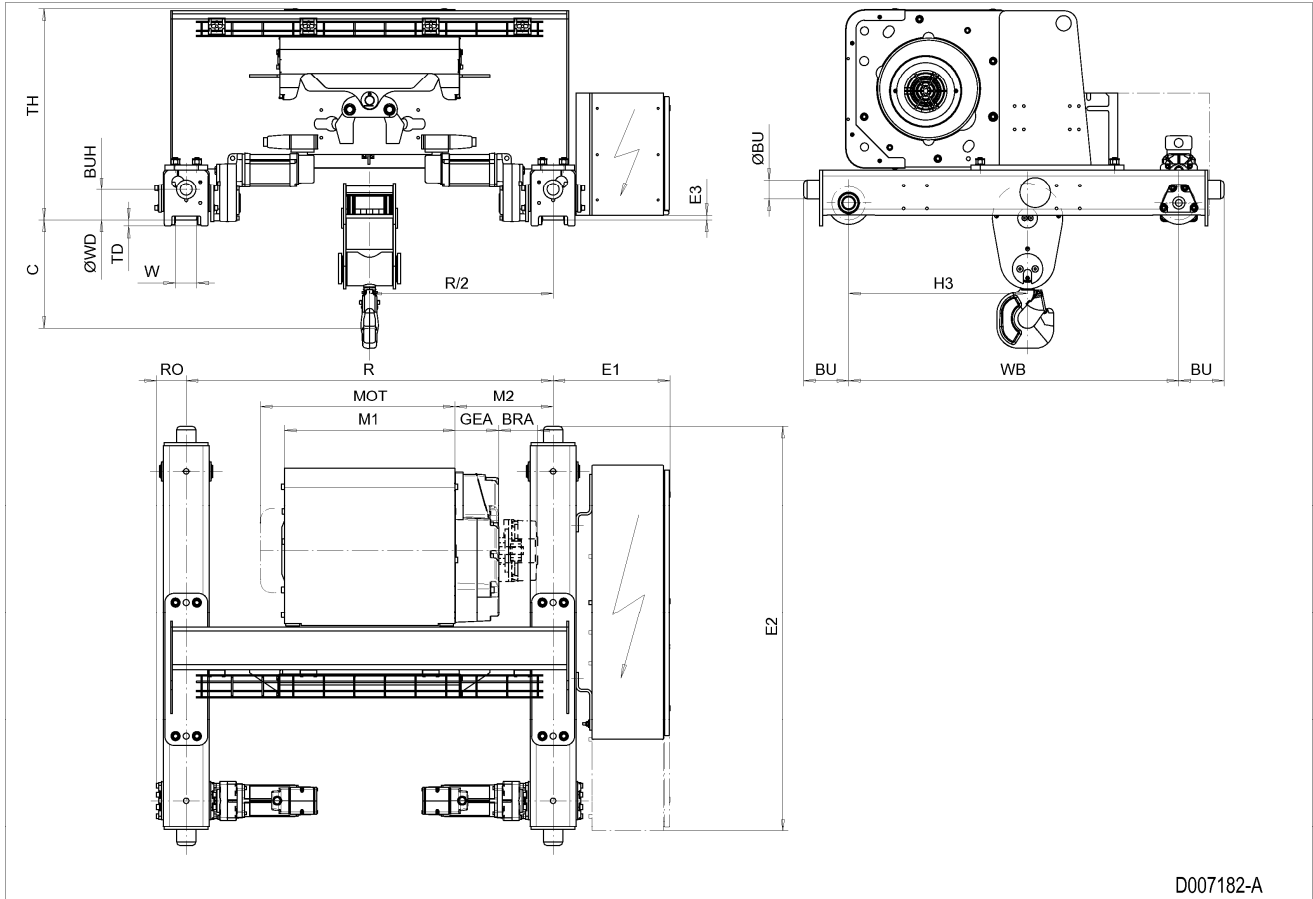

D007182-A

45 HIGH DOUBLE GIRDER HOIST ND, REEVING: 24

Hoist dimensions

HOL m	Length code	M1 mm	M2 mm	BRA mm	Min R mm	Weight kg
4	D	558	321	-	1200	740
6.5	E	678	261	-	1200	760
9	F	828	286	-	1400	800
12.5	G	1018	341	-	1700	850
16.5	H	1268	216	128	1700	905
23	J	1618	424	128	2400	1015

Motor dimensions

Motor	P5	P6	P7	A5	S5	S7
MOT (mm)	578	578	618	498	606	757
Weight (kg)	58	85	105	45	53	81

Trolley dimensions

C	ØBU	BU	BUH	E1	E2	E3	GEA	H3	WB	ØWD	W min
520	63	148	100	382	1328	15	143	585	1080	110	52
W max	RO	TD	TH								
87	98	20	692								

D007183_A
124427

Note: All dimensions in mm.

Note: M2 and weight calculated with P5 motor and Min R.

Note: Min R with service platform and second brake.

Note: Standard rail gauges: 1200, 1400, 1700, 2000 and 2400.

Note: Gear brake as standard brake for drum lengths H and J.

Note: Flangeless wheels available.

High Double Girder Hoist ND, REEVING: 24

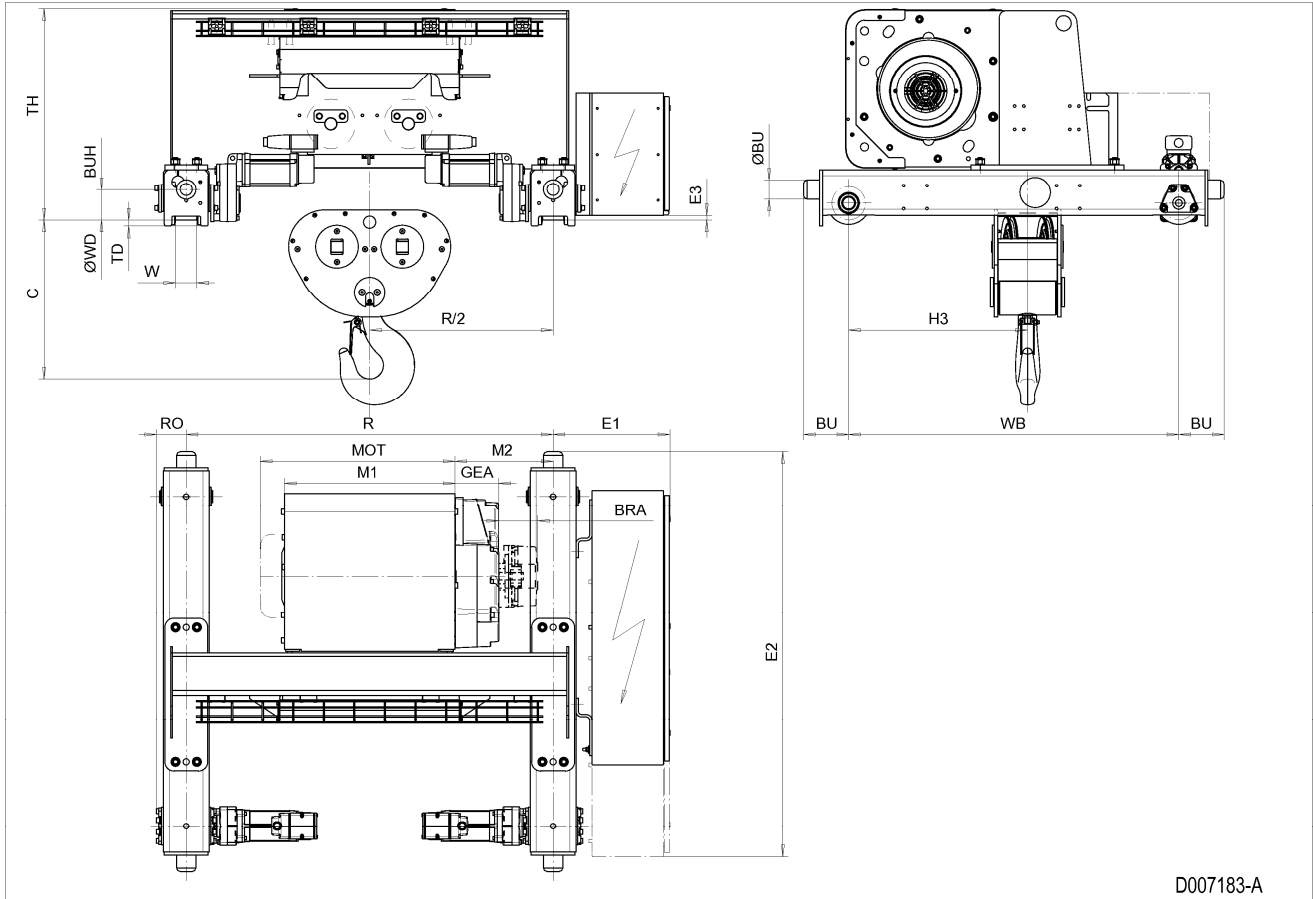

D007183-A

46 HIGH DOUBLE GIRDER HOIST ND, REEVING: 26

Hoist dimensions

HOL m	Length code	M1 mm	M2 mm	BRA mm	Min R mm	Weight kg
4	E	678	261	-	1200	790
6	F	828	286	-	1400	830
8	G	1018	341	-	1700	885
11	H	1268	216	128	1700	935
15	J	1618	424	128	2400	1050

Motor dimensions

Motor	P5	P6	P7	A5	S5	S7
MOT (mm)	578	578	618	498	606	757
Weight (kg)	58	85	105	45	53	81

Trolley dimensions

C	ØBU	BU	BUH	E1	E2	E3	GEA	WB	ØWD	W min	W max
520	63	163	100	382	1343	18	143	1080	140	54	84
RO	TD	TH									
98	20	695									

D007184_A
124428

Note: All dimensions in mm.

Note: M2 and weight calculated with P5 motor and Min R.

Note: Min R with service platform and second brake.

Note: Standard rail gauges: 1200, 1400, 1700, 2000 and 2400.

Note: Gear brake as standard brake for drum lengths H and J.

Note: Flangeless wheels available.

High Double Girder Hoist ND, REEVING: 26

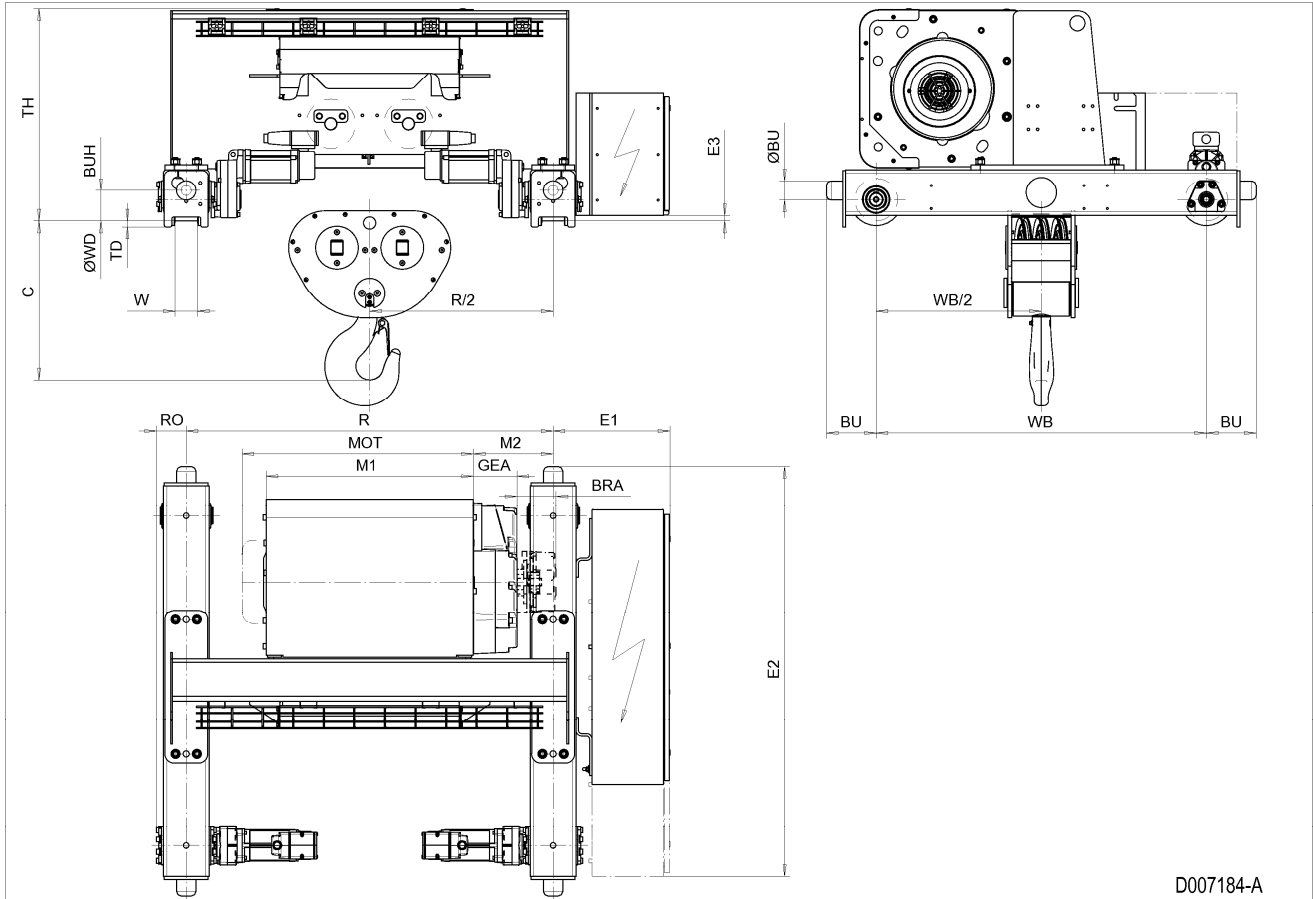

D007184-A

47 HIGH DOUBLE GIRDER HOIST ND, REEVING: 28

Hoist dimensions

HOL m	Length code	M1 mm	M2 mm	BRA mm	Min R mm	Weight kg
4.5	F	828	286	-	1400	840
6	G	1018	341	-	1700	895
8	H	1268	216	128	1700	945
11.5	J	1618	424	128	2400	1060

Motor dimensions

Motor	P5	P6	P7	A5	S5	S7
MOT (mm)	578	578	618	498	606	757
Weight (kg)	58	85	105	45	53	81

Trolley dimensions

C	ØBU	BU	BUH	E1	E2	E3	GEA	WB	ØWD	W min	W max
520	63	163	100	382	1343	18	143	1080	140	54	84
RO	TD	TH									
98	20	695									

D007185_A
124429

Note: All dimensions in mm.

Note: M2 and weight calculated with P5 motor and Min R.

Note: Min R with service platform and second brake.

Note: Standard rail gauges: 1400, 1700, 2000 and 2400.

Note: Gear brake as standard brake for drum lengths H and J.

Note: Flangeless wheels available.

High Double Girder Hoist ND, REEVING: 28

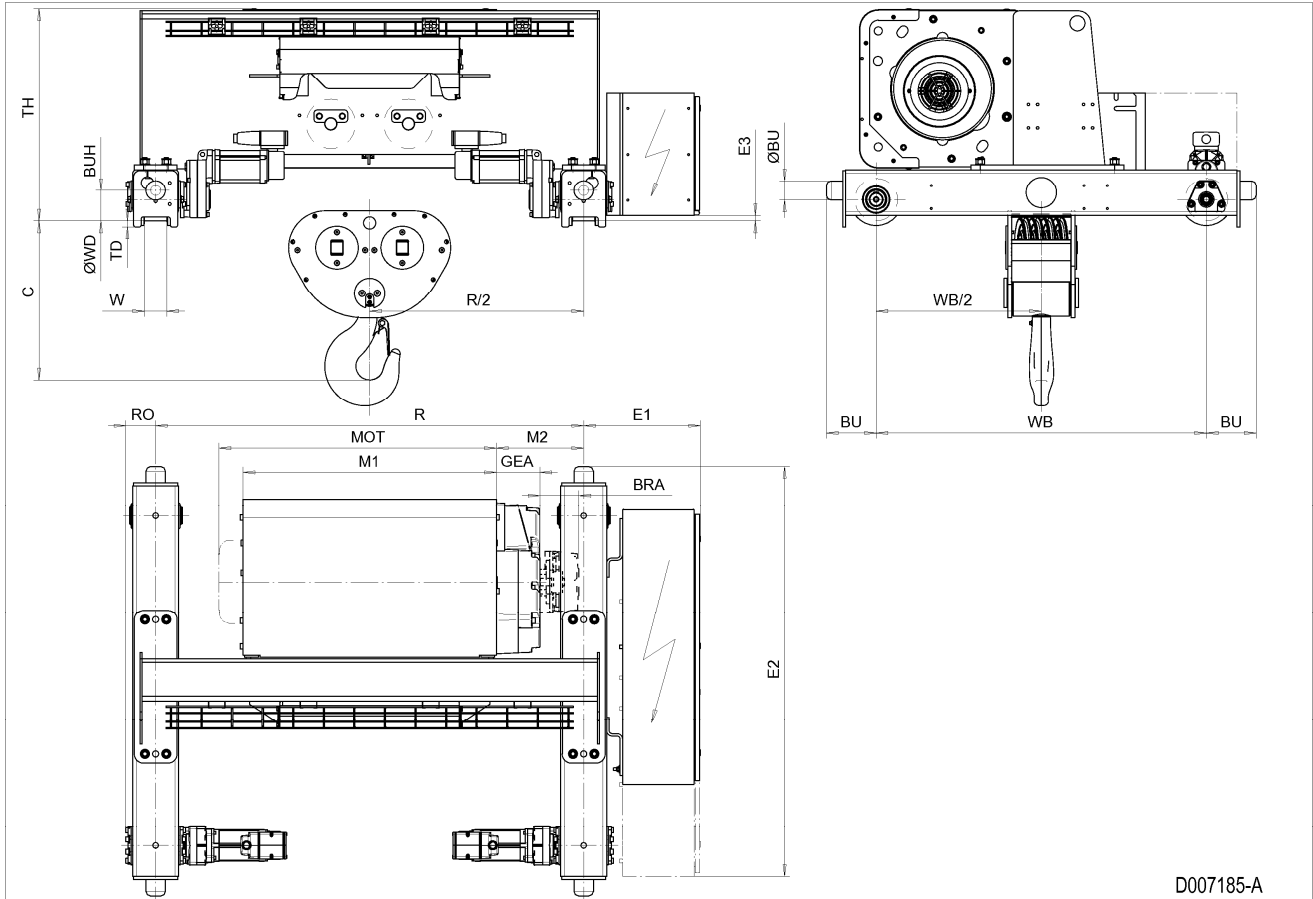

D007185-A

DOUBLE GIRDER TROLLEY, LOW

48 LOW DOUBLE GIRDER HOIST ND, REEVING: 02

Hoist dimensions

HOL m	Length code	M1 mm	M2 mm	H1 mm	H2 mm	Min R mm	Weight kg
18	D	558	403	558	176	1400	650
24	E	678	403	558	235	1400	675
32	F	828	516	671	309	1700	720
40	G	1018	666	821	403	2000	760

Motor dimensions

Motor	P5	P6	P7	A5	S5	S7
MOT (mm)	578	578	618	498	606	757
Weight (kg)	58	85	105	45	53	81

Trolley dimensions

C	ØBU	BU	BUH	E1	E2	E3	GEA	H3	WB	ØWD	W min
615	63	148	100	342	1028	5	143	552	1080	110	52
W max	RO	TD	TH								
87	98	265	252								

D002115_A
005058

Note: All dimensions in mm.

Note: H1, M2 and weight calculated with P5 motor and Min R.

Note: Motor S7 is unavailable for load class 6300 kg.

Note: Min R with service platform and second brake.

Note: Standard rail gauges: 1400, 1700 and 2000.

Note: Flangeless wheels available.

Low Double Girder Hoist ND, REEVING: 02

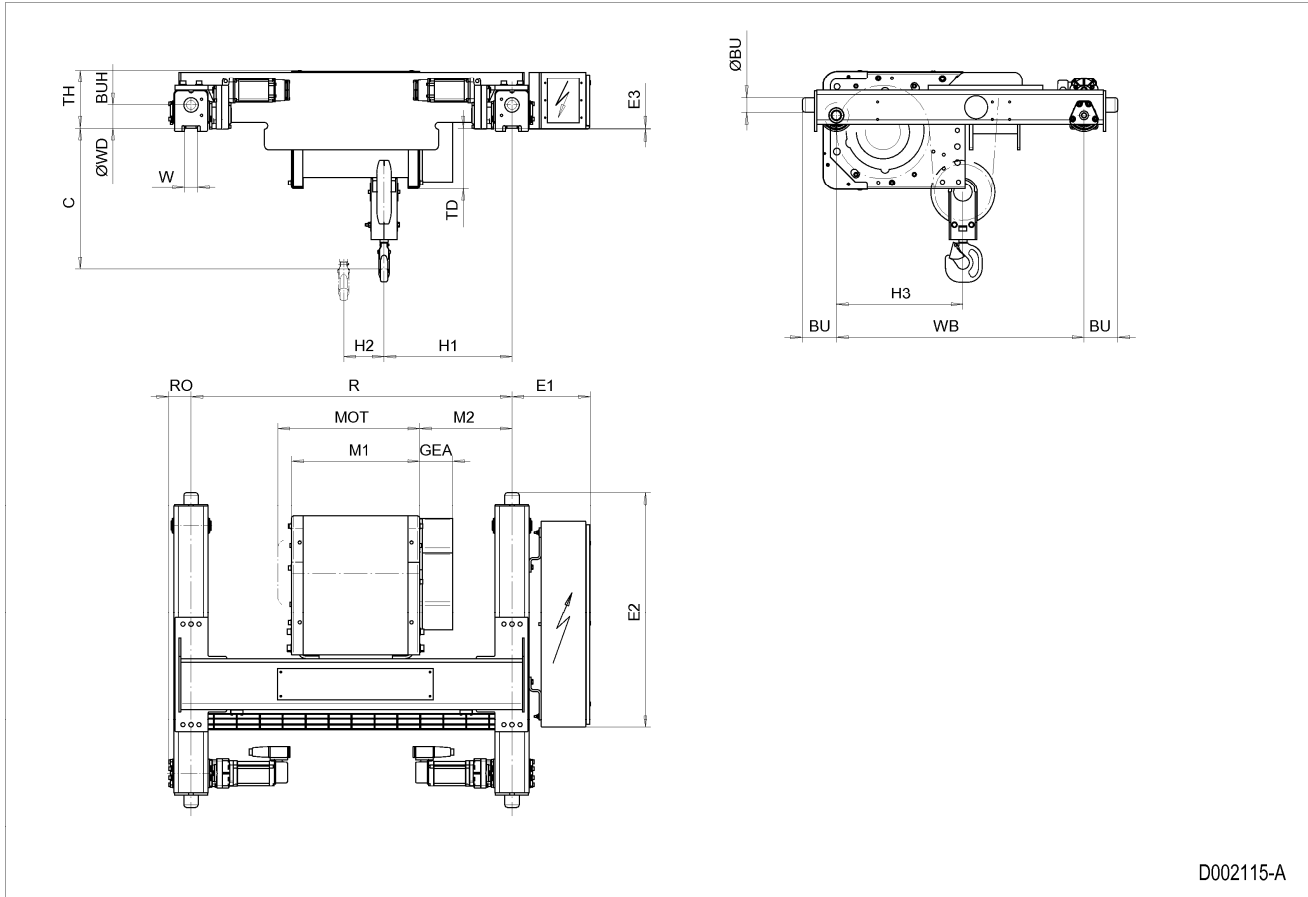

D002115-A

49 LOW DOUBLE GIRDER HOIST ND, REEVING: 04

Hoist dimensions

HOL m	Length code	M1 mm	M2 mm	H1 mm	H2 mm	Min R mm	Weight kg
9	D	558	403	640	88	1400	670
12	E	678	403	640	118	1400	700
16	F	828	516	753	156	1700	745
20	G	1018	666	903	204	2000	785

Motor dimensions

Motor	P5	P6	P7	A5	S5	S7
MOT (mm)	578	578	618	498	606	757
Weight (kg)	58	85	105	45	53	81

Trolley dimensions

C1	C2	ØBU	BU	BUH	E1	E2	E3	GEA	H3	WB	ØWD
595	651	63	148	100	342	1028	5	143	585	1080	110
W min	W max	RO	TD	TH							
52	87	98	265	252							

D002122_A
005060

Note: All dimensions in mm.

Note: H1, M2 and weight calculated with P5 motor and Min R.

Note: Motor S7 is unavailable for load class 12500 kg.

Note: Min R with service platform and second brake.

Note: Standard rail gauges: 1400, 1700 and 2000.

Note: Flangeless wheels available.

Low Double Girder Hoist ND, REEVING: 04

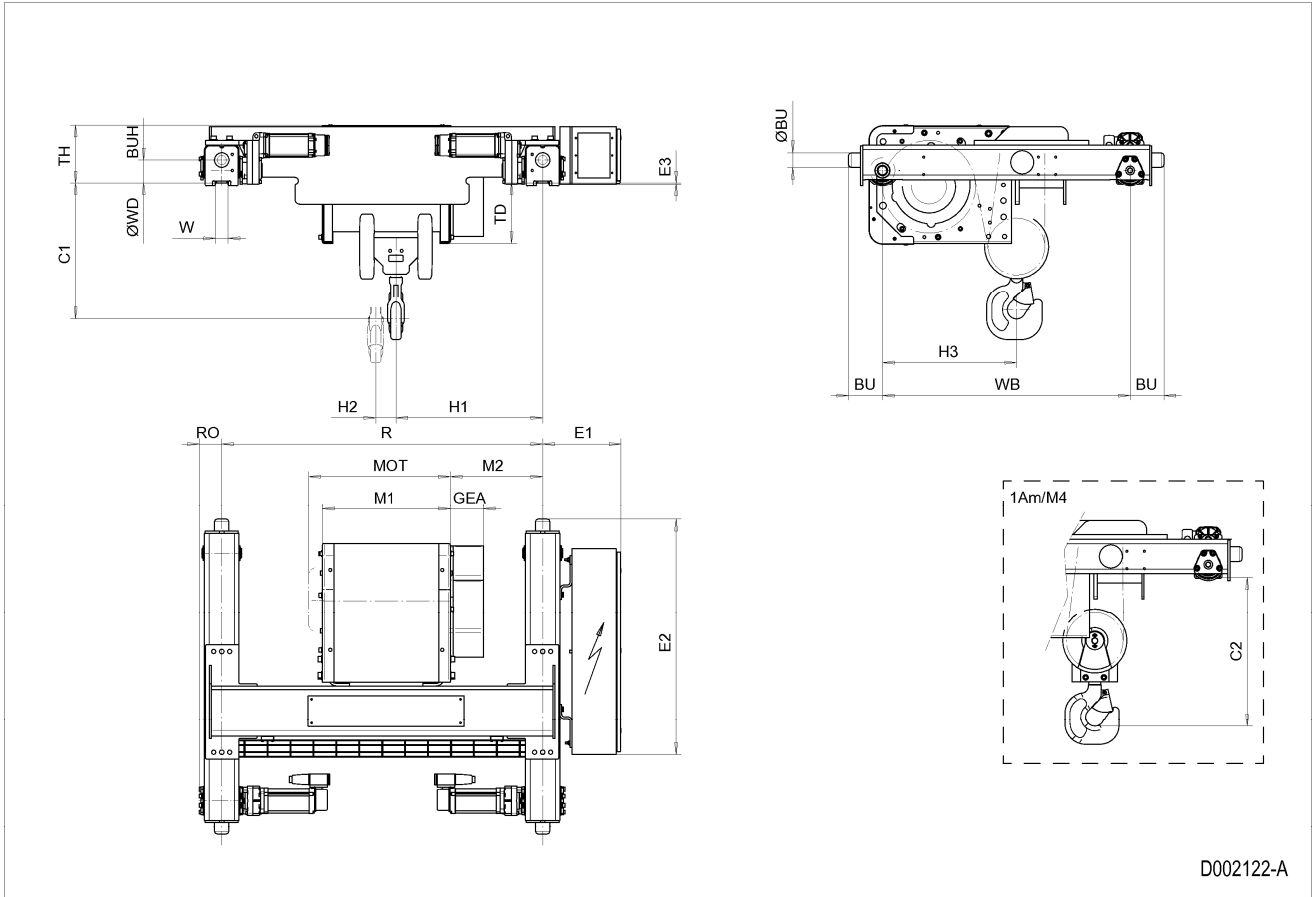

NORMAL HEADROOM TROLLEY

50 NORMAL HEADROOM HOIST NB, REEVING: 02

Hoist dimensions

HOL m	Length code	M1 mm	H2 mm	H3 mm	H3* mm	BF mm	Weight kg
12	A	326	90	447	462	58	250
19	C	456	144	447	462	58	270

Motor dimensions

Motor	P1	P2	P3	A3	S3
MOT (mm)	386	446	476	446	526
Weight (kg)	21	31	35	32	28

Travelling dimensions

Motor	MF06LA
TMO (mm)	400
Weight (kg)	7.8

Trolley dimensions

B min.	B max.	C	ØBU	ØWD	BU	BUF	BUH	E1	E2	GEA	H1
100	450	740	63	100	253	412	40	241	372	110	190
H4	M2	TF	TD	TH	TW						
633	96	45	557	150	31						

D002077_A
062129

Minimum track radius

B	Min R
100 - 109	2500
110 - 119	2000
120 - 450	1500

Note: All dimensions in mm.

Note: Weight calculated with P1 motor when B=300 mm.

Note: Additional travelling machinery for curved track (option) indicated with an 'X' in the drawing.

* Please, disregard the dimension H3*.

Normal Headroom Hoist NB, REEVING: 02

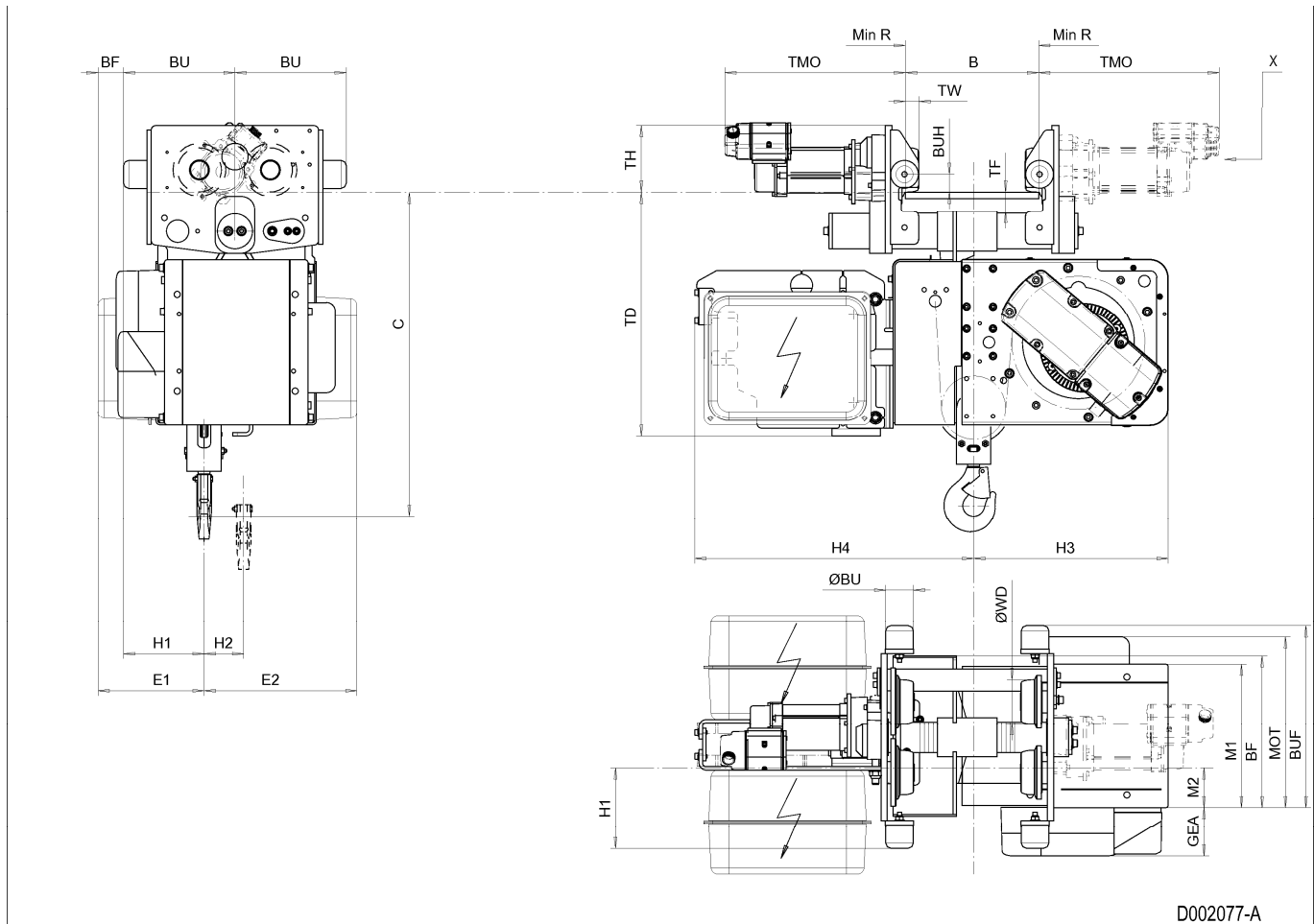

D002077-A

51 NORMAL HEADROOM HOIST NB, REEVING: 04

Hoist dimensions

HOL m	Length code	M1 mm	H2 mm	H3 mm	H3* mm	BF mm	Weight kg
6	A	326	45	465	480	58	260
9.5	C	456	72	465	480	58	300

Motor dimensions

Motor	P1	P2	P3	A3	S3
MOT (mm)	386	446	476	446	526
Weight (kg)	21	31	35	32	28

Travelling dimensions

Motor	MF06LA
TMO (mm)	400
Weight (kg)	7.8

Trolley dimensions

B min.	B max.	C	ØBU	ØWD	BU	BUF	BUH	E1	E2	GEA	H1
80	450	690	63	100	253	412	40	296	317	110	238
H4	M2	TF	TD	TH	TW						
617	151	45	557	150	31						

D002082_A
062130

Minimum track radius

B	Min R
100 - 109	2500
110 - 119	2000
120 - 450	1500

Note: All dimensions in mm.

Note: Weight calculated with P1 motor, when B=300 mm.

Note: Additional travelling machinery for curved track (option) indicated with an 'X' in the drawing.

* Please, disregard the dimension H3*.

Normal Headroom Hoist NB, REEVING: 04

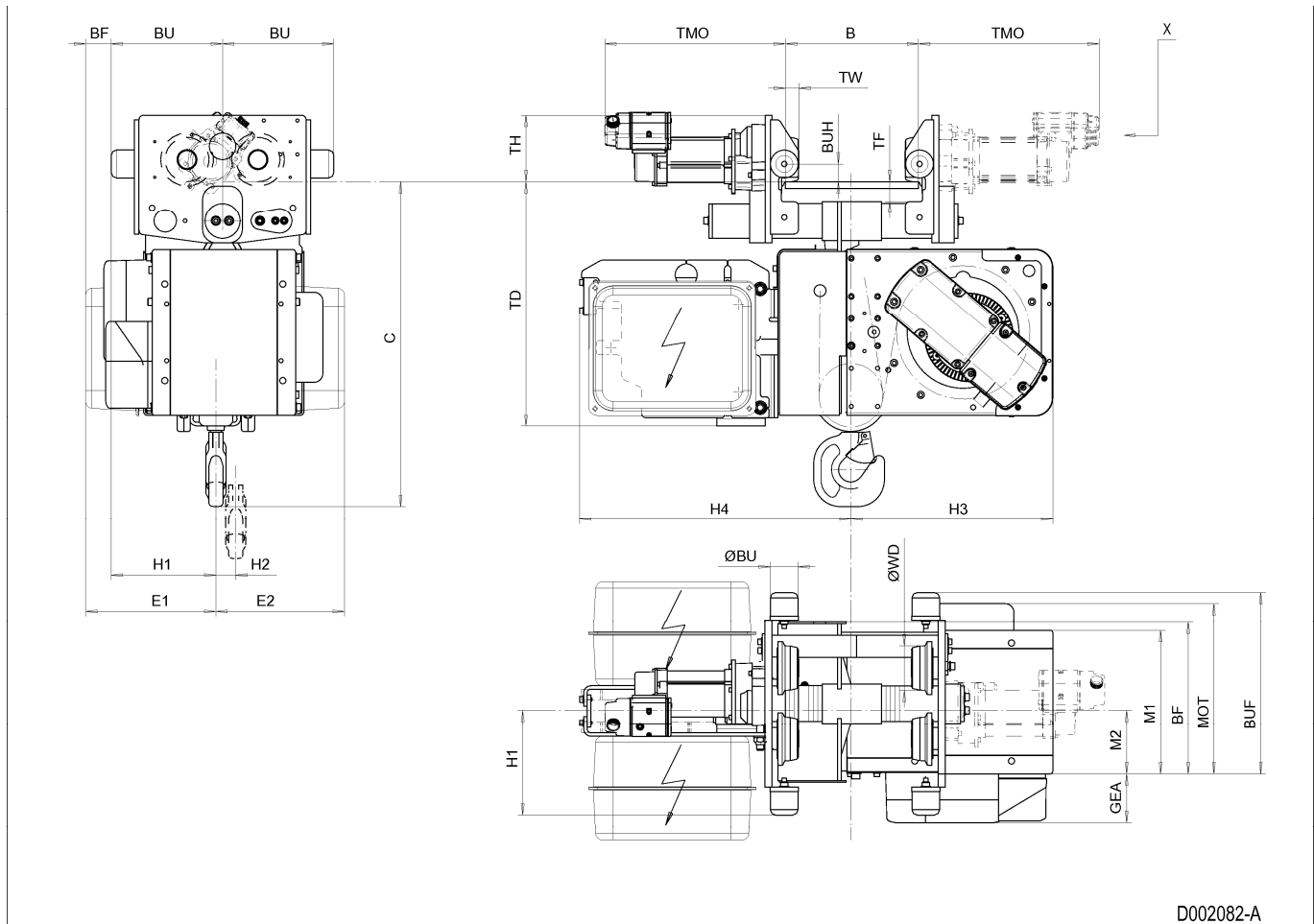

D002082-A

52 NORMAL HEADROOM HOIST NC, REEVING: 02

Hoist dimensions

HOL m	Length code	BU mm	BUF mm	BF mm	M1 mm	H1 mm	H2 mm	H3 mm	H3* mm	Weight kg
12	B	373	586	269	356	244	98	532	548	350
18	C	373	586	269	456	244	147	532	548	390
24	D	373	586	373	556	244	198	532	548	420
30	E	253	737	218	676	274	258	532	548	480

Motor dimensions

Motor	P3	P4	A3	S3	S5
MOT (mm)	473	574	443	523	602
Weight (kg)	35	53	32	28	53

Travelling dimensions

Motor	MF06LA
TMO (mm)	400
Weight (kg)	7.8

Trolley dimensions

B min	B max	C	ØBU	ØWD	BUH	GEA	H4	M2	TD	TF	TH
120	450	835	63	100	40	116	665	87	586	40	150
TS	TW										
420	31										

Trolley dimensions

Length code	E1	E2
B/C/D	233	505
E	199	540

D002090_A
062140

Note: All dimensions in mm.

Note: Weight calculated with P3 motor, when B=300 mm.

Note: Motor S5 is unavailable for load class 3200 kg.

* Please, disregard the dimension H3*.

Normal Headroom Hoist NC, REEVING: 02

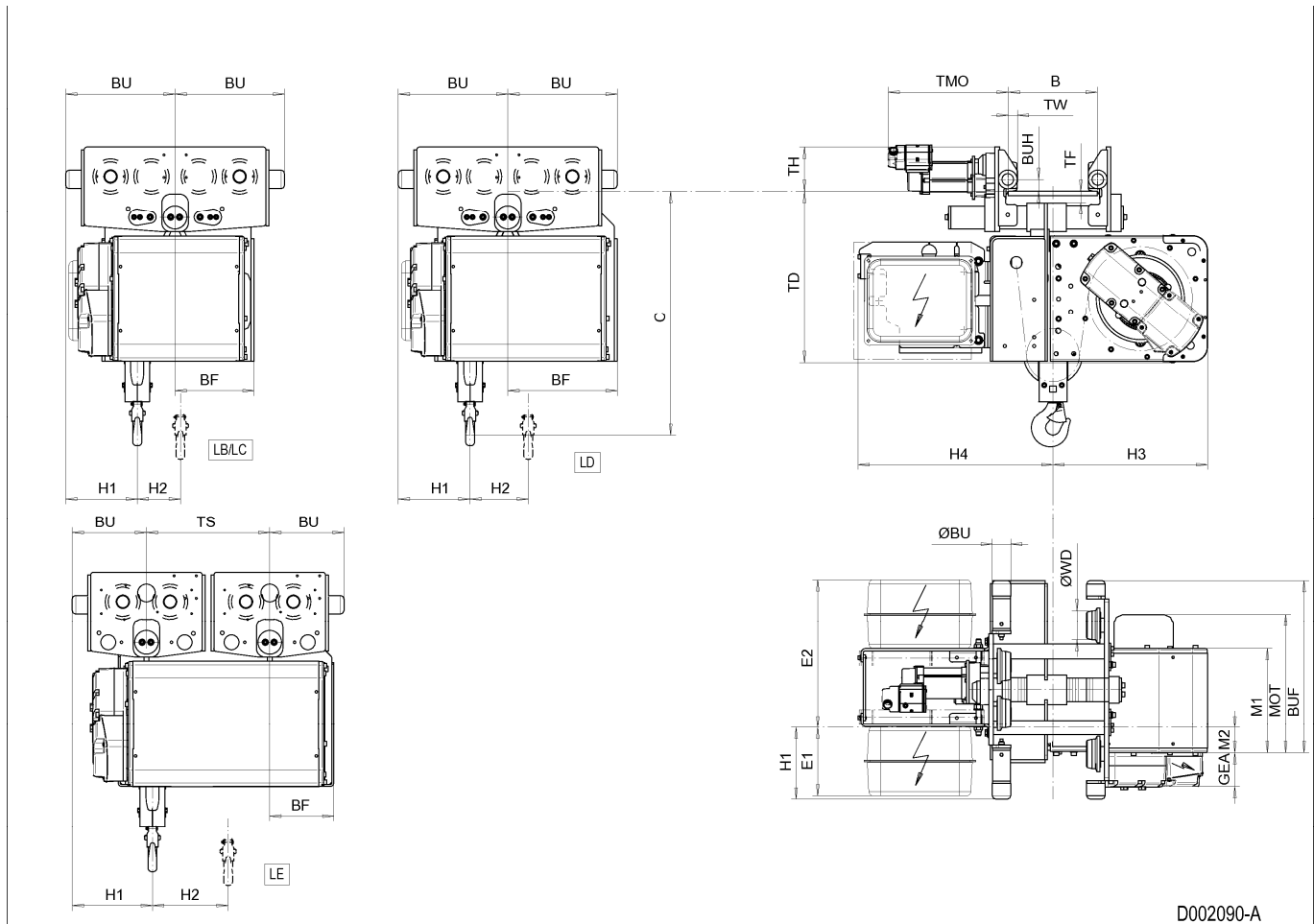

53 NORMAL HEADROOM HOIST NC, REEVING: 02, CURVED TRACK

Hoist dimensions

HOL m	Length code	M1 mm	H2 mm	H3 mm	H3* mm	Weight kg
12	B	356	98	532	548	470
18	C	456	147	532	548	490
24	D	556	198	532	548	530
30	E	676	258	532	548	540

Motor dimensions

Motor	P3	P4	A3	S3	S5
MOT (mm)	473	574	443	523	602
Weight (kg)	35	53	32	28	53

Travelling dimensions

Motor	MF06LA
TMO (mm)	400
Weight (kg)	7.8

Trolley dimensions

B min	B max	C	ØBU	ØWD	BU	BUF	BUH	GEA	H1	H4	M2
90	350	995	63	100	253	790	40	116	350	663	113
TD	TF	TH	TS	TW							
746	42	150	523	31							

D003840_A
062168

Track radius

B	R min
90 - 109	2500
110 - 119	2000
120 - 350	1500

Note: All dimensions in mm.

Note: Weight calculated with P3 motor.

Note: Motor S5 is unavailable for load class 3200 kg.

* Please, disregard the dimension H3*.

Normal Headroom Hoist NC, REEVING: 02, Curved Track

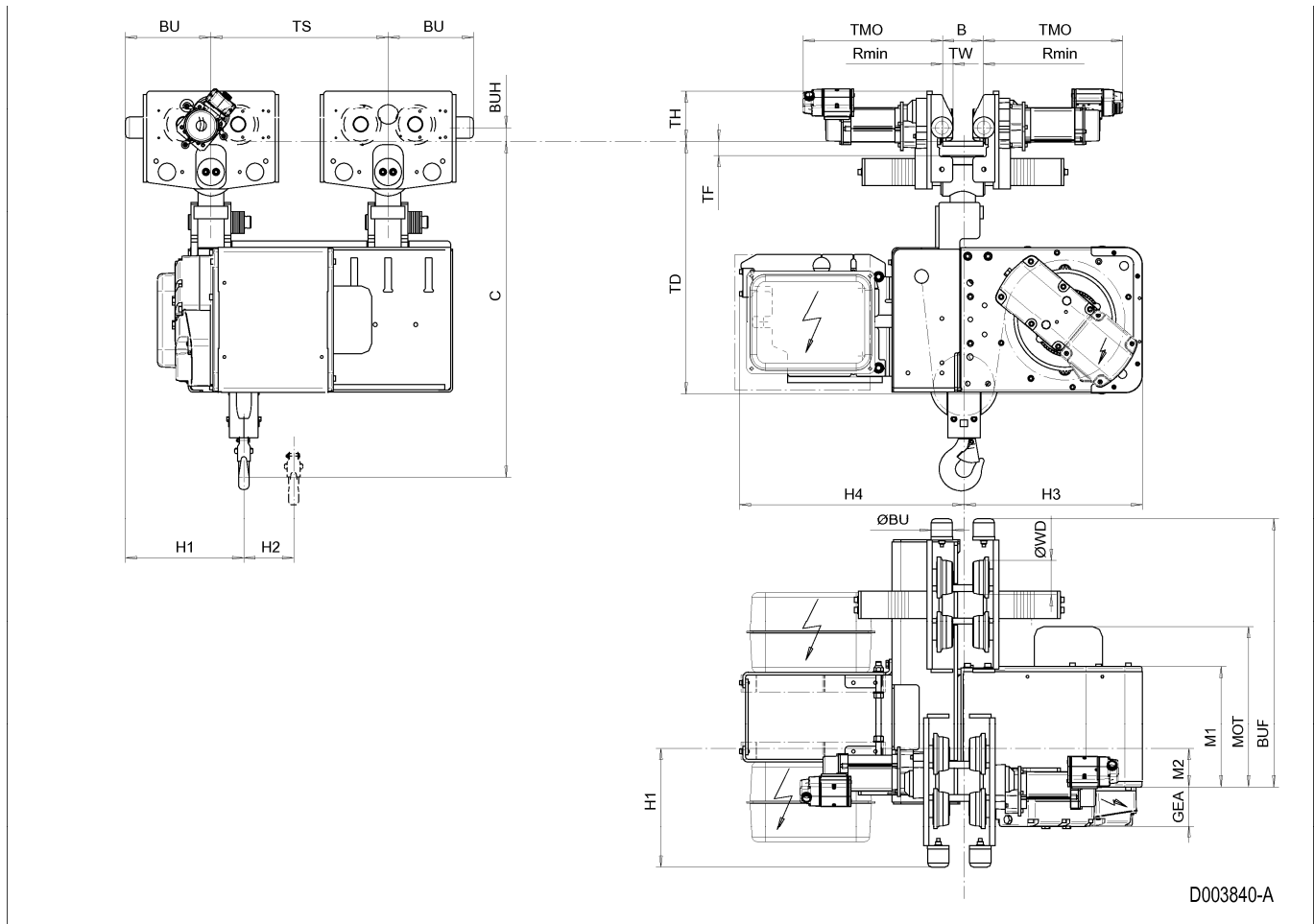

54 NORMAL HEADROOM HOIST NC, REEVING: 04

Hoist dimensions

HOL m	Length code	BU mm	BUF mm	BF mm	M1 mm	H1 mm	H2 mm	H3 mm	H3* mm	Weight kg
6	B	253	466	269	356	205	49	555	571	470
9	C	253	466	269	456	205	73	555	571	490
12	D	373	586	373	556	325	97	555	571	530
15	E	253	737	218	676	354	121	555	571	540

Motor dimensions

Motor	P3	P4	A3	S3	S5
MOT (mm)	473	574	443	523	602
Weight (kg)	35	53	32	28	53

Travelling dimensions

Motor	MF06LA
TMO (mm)	400
Weight (kg)	7.8

Trolley dimensions

B min	B max	C	ØBU	ØWD	BUH	GEA	H4	M2	TD	TF	TH
80	450	870	63	100	40	116	638	168	586	40	150
TS	TW										
420	31										

Trolley dimensions

Length code	E1	E2
B/C/D	313	425
E	284	454

D002097_A
062143

Note: All dimensions in mm.

Note: Weight calculated with P3 motor, when B=300 mm.

Note: Motor S5 is unavailable for load class 6300 kg.

* Please, disregard the dimension H3*.

Normal Headroom Hoist NC, REEVING: 04

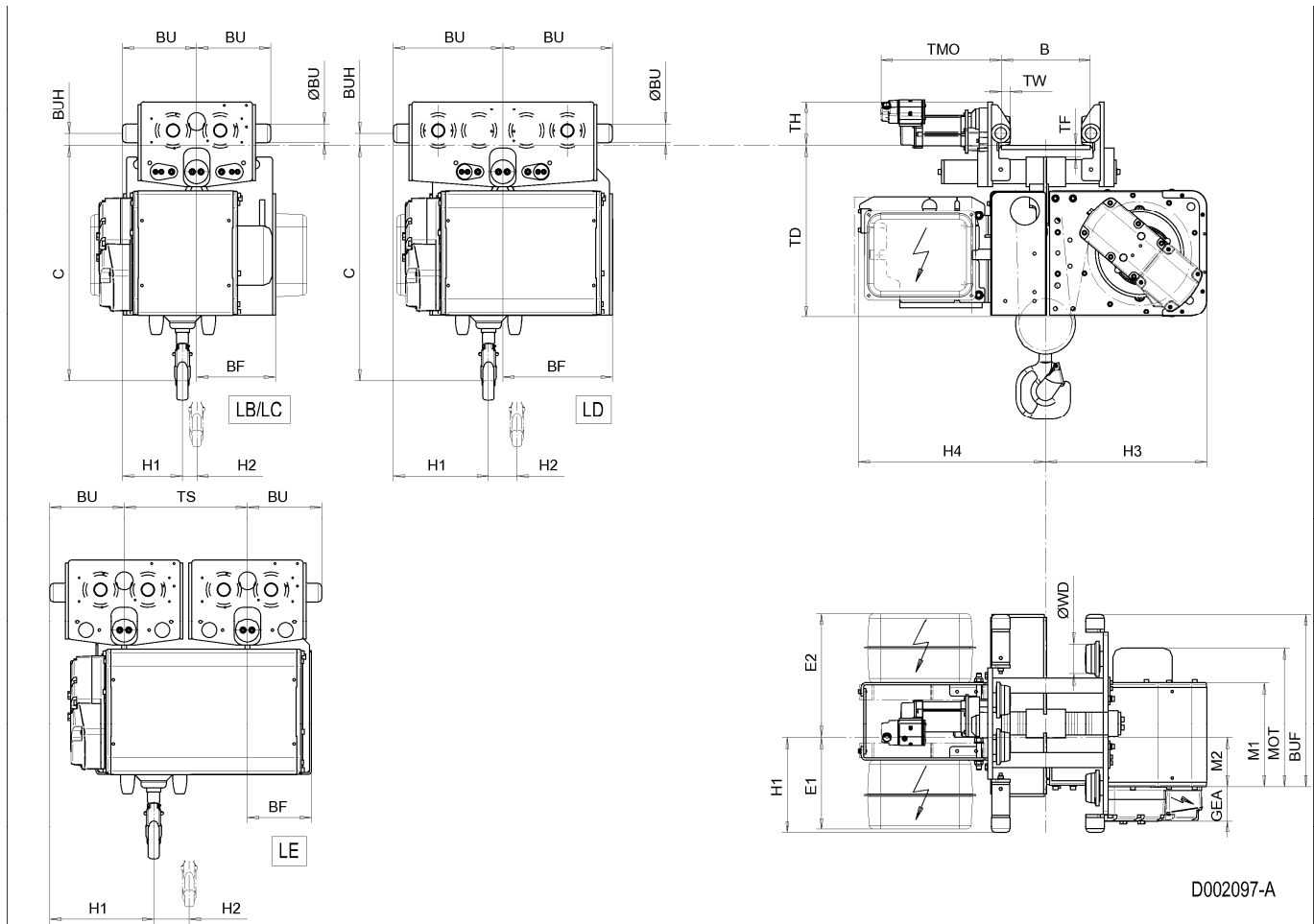

55 NORMAL HEADROOM HOIST NC, REEVING: 04, CURVED TRACK

Hoist dimensions

HOL m	Length code	M1 mm	M2 mm	H1 mm	H2 mm	H3 mm	H3* mm	Weight kg
6	B	356	165	205	49	555	571	360
9	C	456	165	205	73	555	571	400
12	D	556	193	430	97	555	571	550
15	E	676	193	430	121	555	571	565

Motor dimensions

Motor	P3	P4	A3	S3	S5
MOT (mm)	473	574	443	523	602
Weight (kg)	35	53	32	28	53

Travelling dimensions

Motor	MF06LA
TMO (mm)	400
Weight (kg)	7.8

Trolley dimensions

B1 min	B1 max	B2 min	B2 max	C1	C2	ØBU	ØWD	BU	BUH	GEA	H4
80	450	90	350	870	1030	63	100	253	40	116	638
TH	TS	TW									
150	523	31									

Trolley dimensions

Length code	BUF	E1	E2	TD	TF
B/C	522	313	425	586	40
D/E	967	357	381	746	42

D003841_A
062169

Track radius

B	R min
80 - 109	2500
110 - 119	2000
120 - 450	1500

Note: All dimensions in mm.

Note: Weight calculated with P3 motor.

Note: Motor S5 is unavailable for load class 6300 kg.

* Please, disregard the dimension H3*.

Normal Headroom Hoist NC, REEVING: 04, Curved Track

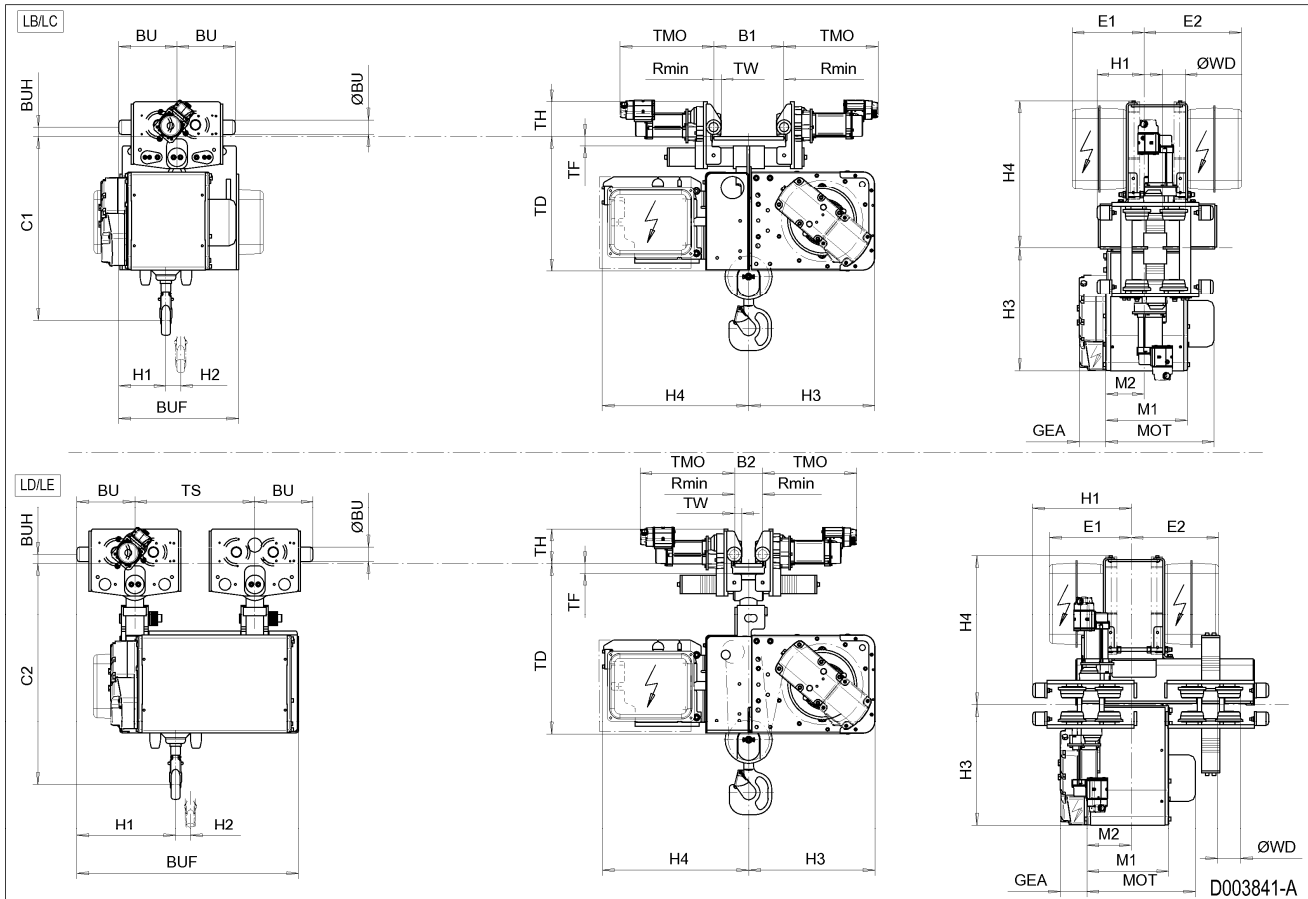

56 NORMAL HEADROOM HOIST ND, REEVING: 02

Hoist dimensions

HOL m	Length code	M1 mm	H1 mm	H2 mm	H3 mm	H3* mm	Weight kg
18	D	558	361	176	625	645	750
24	E	678	361	235	625	645	820
32	F	828	336	309	625	645	900
40	G	1018	336	403	625	645	960

Motor dimensions

Motor	P5	P6	P7	A5	S5	S7
MOT (mm)	578	578	618	498	606	757
Weight (kg)	58	85	105	45	53	81

Travelling dimensions

Motor	MF06MA	MF06LA
TMO (mm)	360	400
Weight (kg)	5.7	7.8

Trolley dimensions

B min	B max	C	ØBU	ØWD	BU	BUH	GEA	H4	M2	TD	TF
120	610	1080	63	100	253	40	143	667	158	700	40
TH	TW										
150	31										

D002114_A
062272

Trolley dimensions

Length code	TS	BUF
D/E	494	924
F/G	522	1239

Note: All dimensions in mm.

Note: Weight calculated with P6 motor, when B=300 mm.

Note: Motor S7 is unavailable for load class 6300 kg.

* Please, disregard the dimension H3*.

Normal Headroom Hoist ND, REEVING: 02

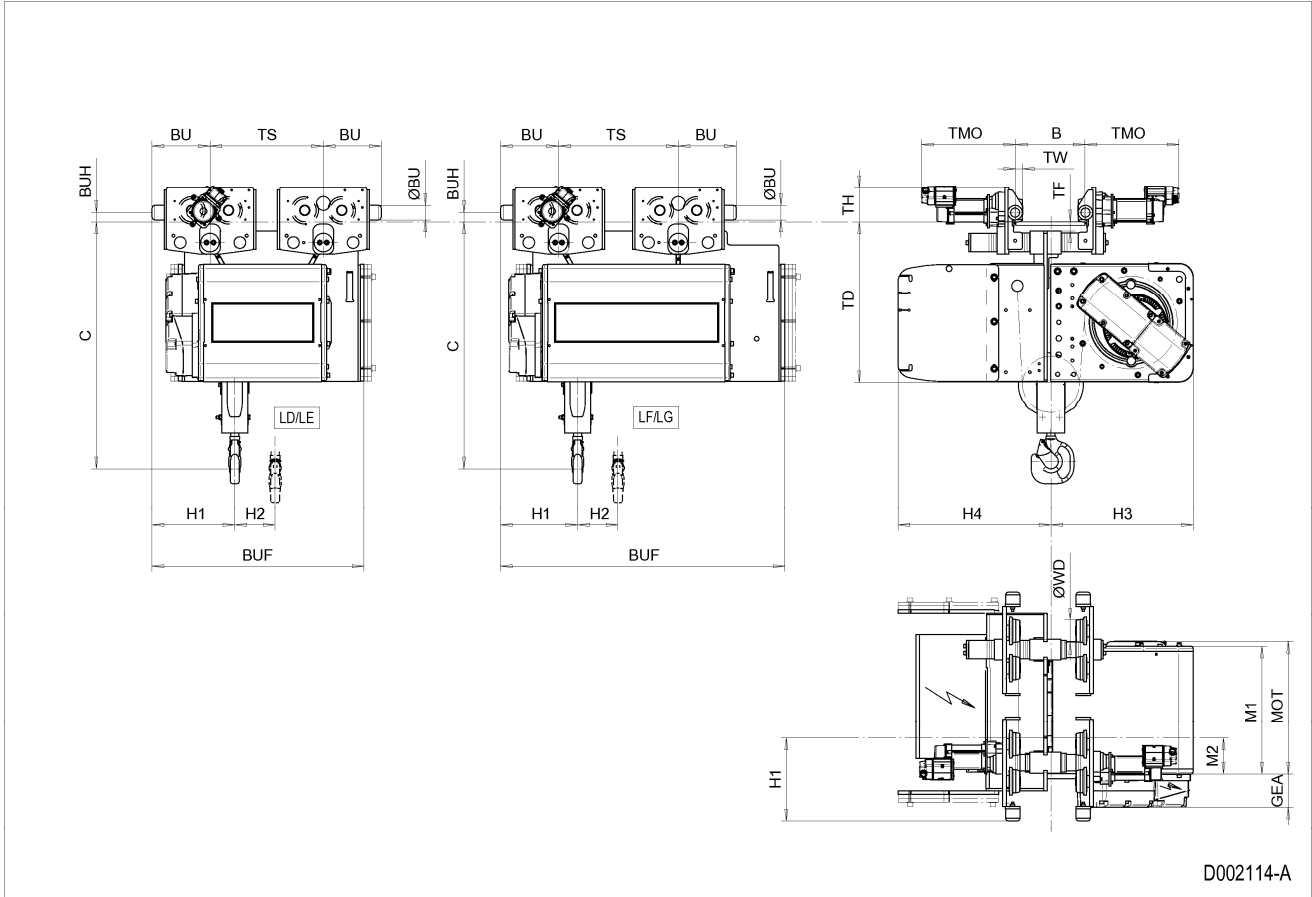

57 NORMAL HEADROOM HOIST ND, REEVING: 02, CURVED TRACK

Hoist dimensions

HOL m	Length code	M1 mm	H2 mm	H3 mm	H3* mm	Weight kg
18	D	558	176	625	645	810
24	E	678	235	625	645	870
32	F	828	309	625	645	940
40	G	1018	403	625	645	1000

Motor dimensions

Motor	P5	P6	P7	A5	S5	S7
MOT (mm)	578	578	618	498	606	757
Weight (kg)	58	85	105	45	53	81

Travelling dimensions

Motor	MF06MA	MF06LA
TMO (mm)	360	400
Weight (kg)	5.7	7.8

Trolley dimensions

B min	B max	C	ØBU	ØWD	BU	BUH	GEA	H1	H4	M2	TD
90	350	1230	63	100	253	40	143	389	667	154	850
TF	TH	TW									
42	150	31									

D004135_A
062273

Trolley dimensions

Length code	TS	BUF
D/E	520	957
F/G	640	1297

Track radius

B	R min
90 - 109	2500
110 - 119	2000
120 - 350	1500

Note: All dimensions in mm.

Note: Weight calculated with P5 motor.

Note: Motor S7 is unavailable for load class 6300 kg.

* Please, disregard the dimension H3*.

Normal Headroom Hoist ND, REEVING: 02, Curved Track

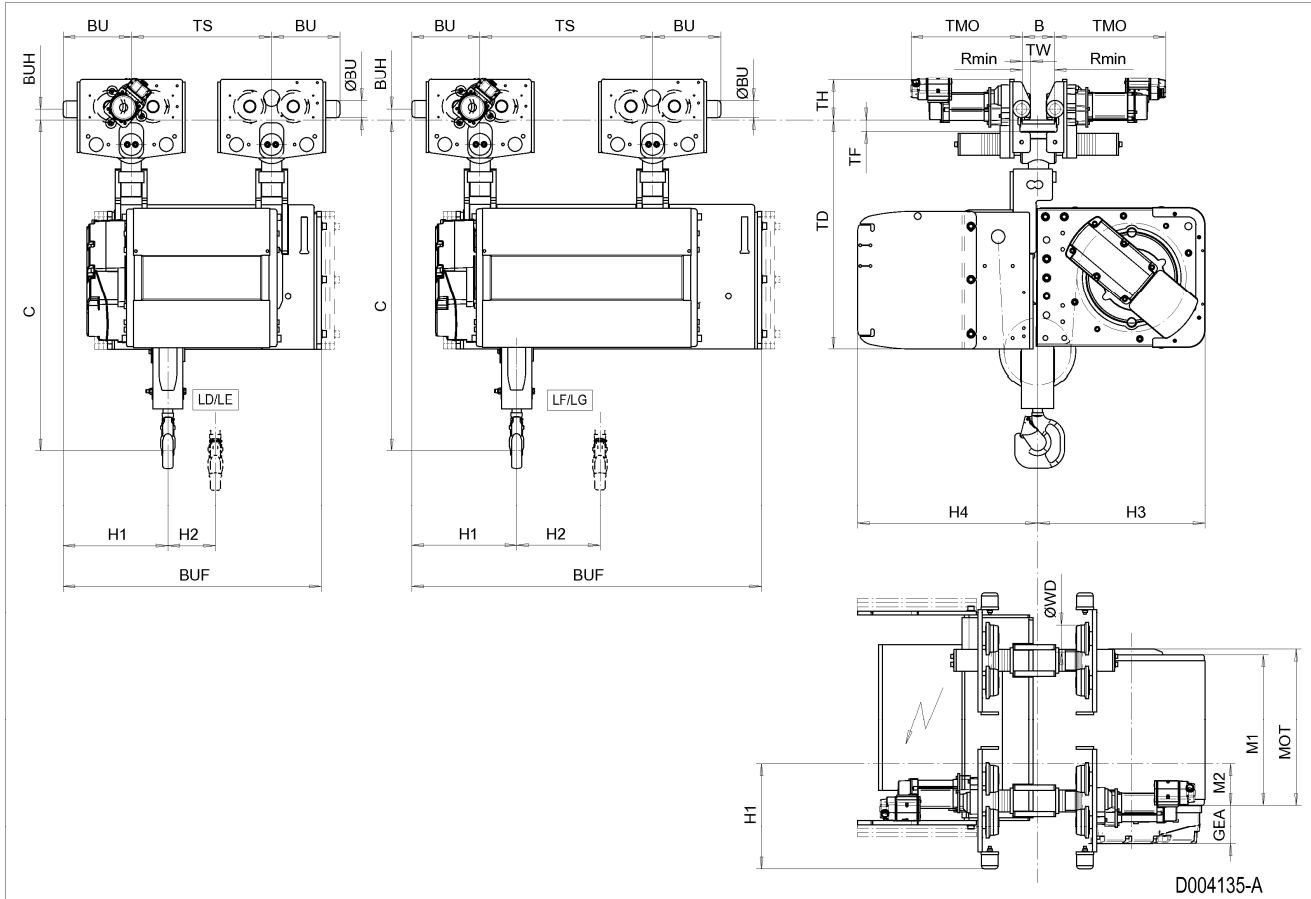

58 NORMAL HEADROOM HOIST ND, REEVING: 04

Hoist dimensions

HOL m	Length code	M1 mm	H1 mm	H2 mm	H3 mm	H3* mm	Weight kg
9	D	558	441	88	649	669	790
12	E	678	441	118	649	669	850
16	F	828	416	156	649	669	930
20	G	1018	416	204	649	669	990

Motor dimensions

Motor	P5	P6	P7	A5	S5	S7
MOT (mm)	578	578	618	498	606	757
Weight (kg)	58	85	105	45	53	81

Travelling dimensions

Motor	MF06MA	MF06LA
TMO (mm)	360	400
Weight (kg)	5.7	7.8

Trolley dimensions

B min	B max	C	ØBU	ØWD	BU	BUH	GEA	H4	M2	TD	TF
80	610	1024	63	100	253	40	143	643	238	700	40
TH	TW										
150	31										

D002120_A
062274

Trolley dimensions

Length code	TS	BUF
D/E	494	924
F/G	522	1239

Note: All dimensions in mm.

Note: Weight calculated with P6 motor, when B=300 mm.

* Please, disregard the dimension H3*.

Normal Headroom Hoist ND, REEVING: 04

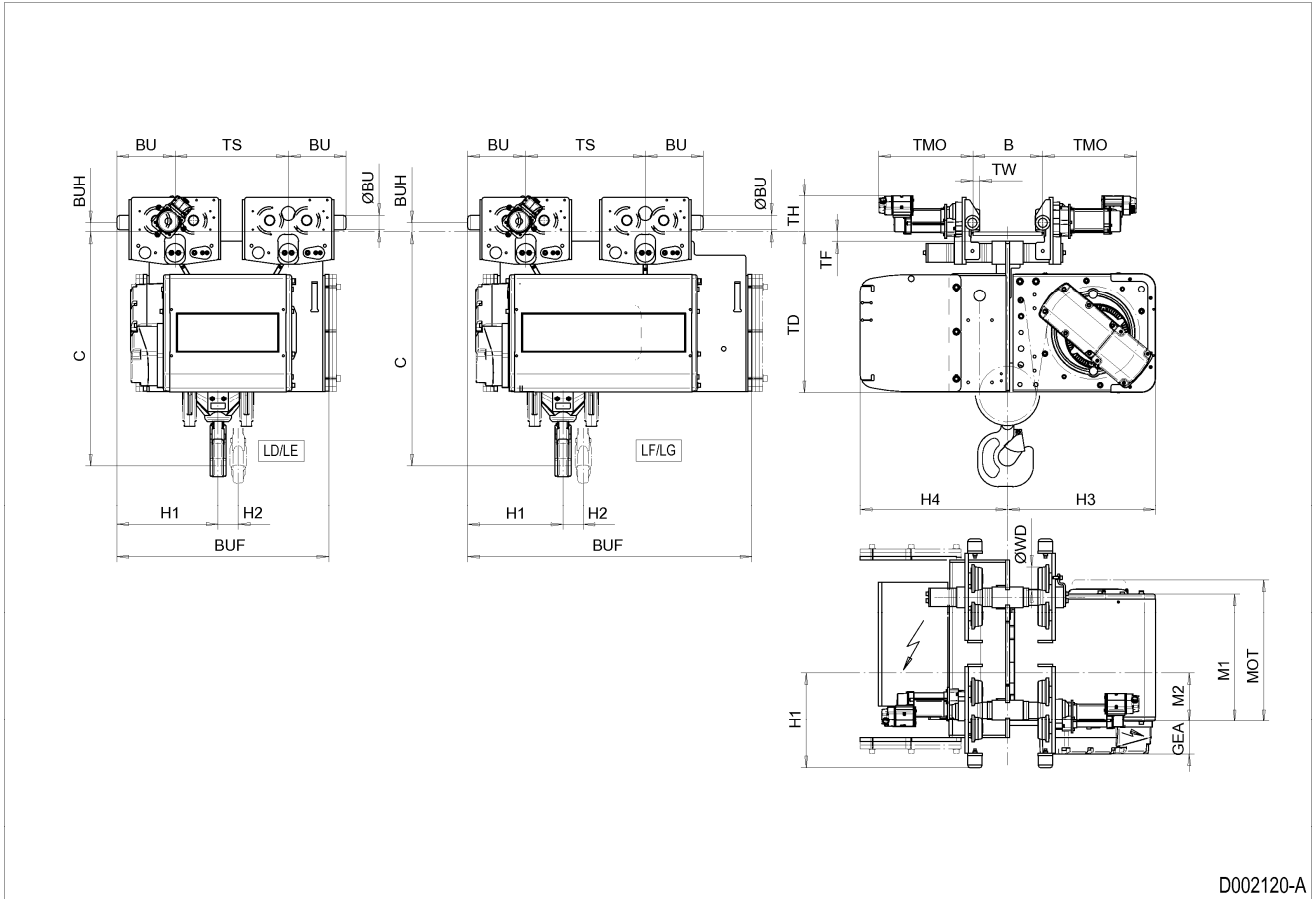

59 NORMAL HEADROOM HOIST ND, REEVING: 04, CURVED TRACK

Hoist dimensions

HOL m	Length code	M1 mm	H2 mm	H3 mm	H3* mm	Weight kg
9	D	558	88	649	669	880
12	E	678	118	649	669	930
16	F	828	156	649	669	1000
20	G	1018	204	649	669	1090

Motor dimensions

Motor	P5	P6	P7	A5	S5	S7
MOT (mm)	578	578	618	498	606	757
Weight (kg)	58	85	105	45	53	81

Travelling dimensions

Motor	MF06MA	MF06LA
TMO (mm)	360	400
Weight (kg)	5.7	7.8

Trolley dimensions

B min	B max	C	ØBU	ØWD	BU	BUH	GEA	H1	H4	M2	TD
90	350	1170	63	100	253	40	143	473	643	238	850
TF	TH	TW									
42	150	31									

D004136_A
062275

Trolley dimensions

Length code	TS	BUF
D/E	520	957
F/G	640	1297

Track radius

B	R min
90 - 109	2500
110 - 119	2000
120 - 350	1500

Note: All dimensions in mm.

Note: Weight calculated with P5 motor.

* Please, disregard the dimension H3*.

Normal Headroom Hoist ND, REEVING: 04, Curved Track

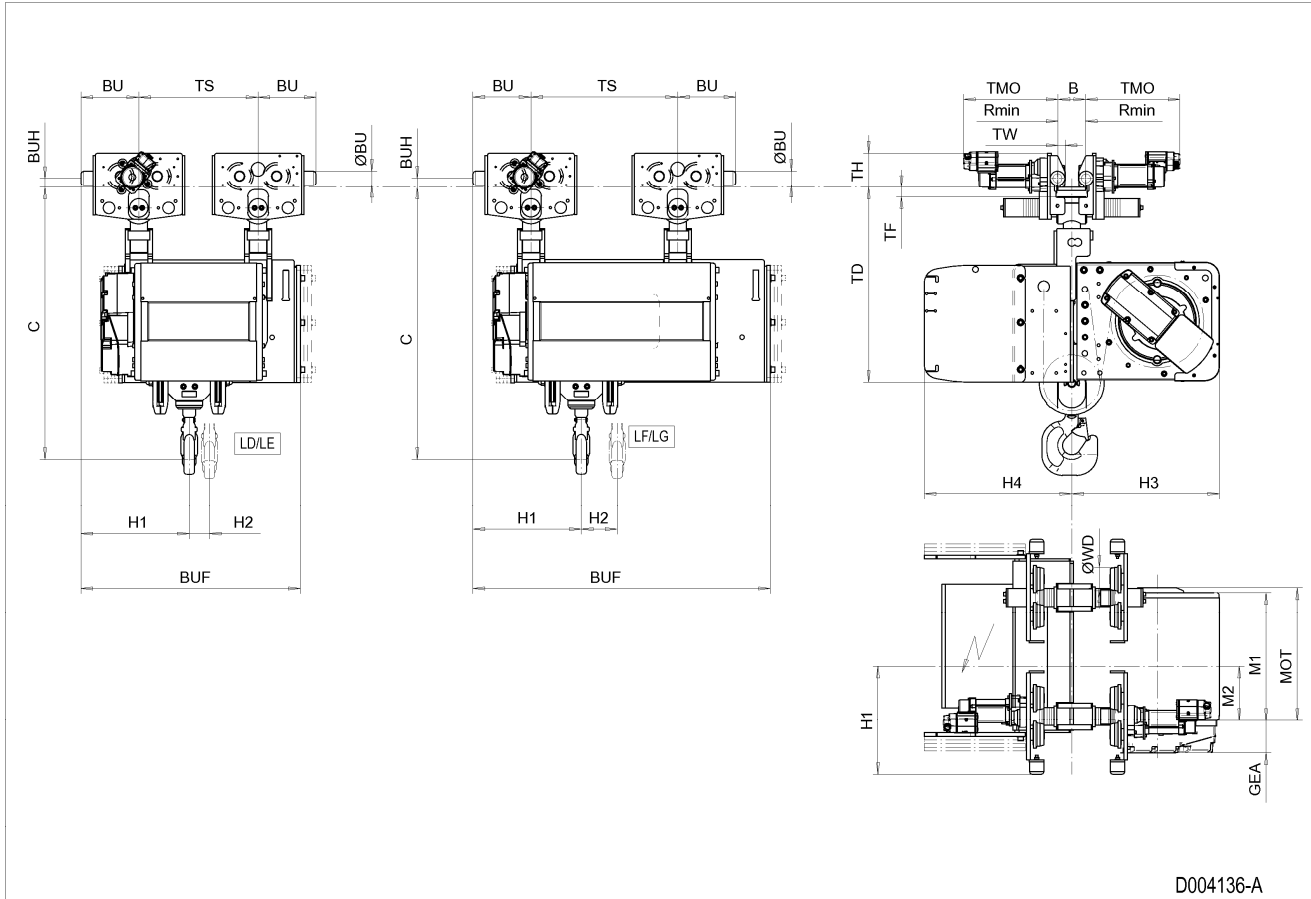

60 NORMAL HEADROOM HOIST ND, REEVING: 06

Hoist dimensions

HOL m	Length code	M1 mm	H1 mm	H2 mm	H3 mm	H3* mm	Weight kg
6	D	558	556	53	605	625	1030
8	E	678	556	78	605	625	1050
10	F	828	596	98	605	625	1140
13	G	1018	596	132	605	625	1195

Motor dimensions

Motor	P5	P6	P7	A5	S5	S7
MOT (mm)	578	578	618	498	606	757
Weight (kg)	58	85	105	45	53	81

Travelling dimensions

Motor	MF06MA	MF06LA
TMO (mm)	360	400
Weight (kg)	5.7	7.8

Trolley dimensions

B min	B max	C	ØBU	ØWD	BU	BUH	GEA	H4	M2	TD	TF
110	610	1413	63	125	288	40	143	612	33	716	40
TH	TW										
170	41.5										

D007206_A
124578

Trolley dimensions

Length code	BF	TS
D/E	110	600
F/G	370	720

Note: All dimensions in mm.

Note: Weight calculated with P5 motor, when B=300 mm

* Please, disregard the dimension H3*.

Normal Headroom Hoist ND, REEVING: 06

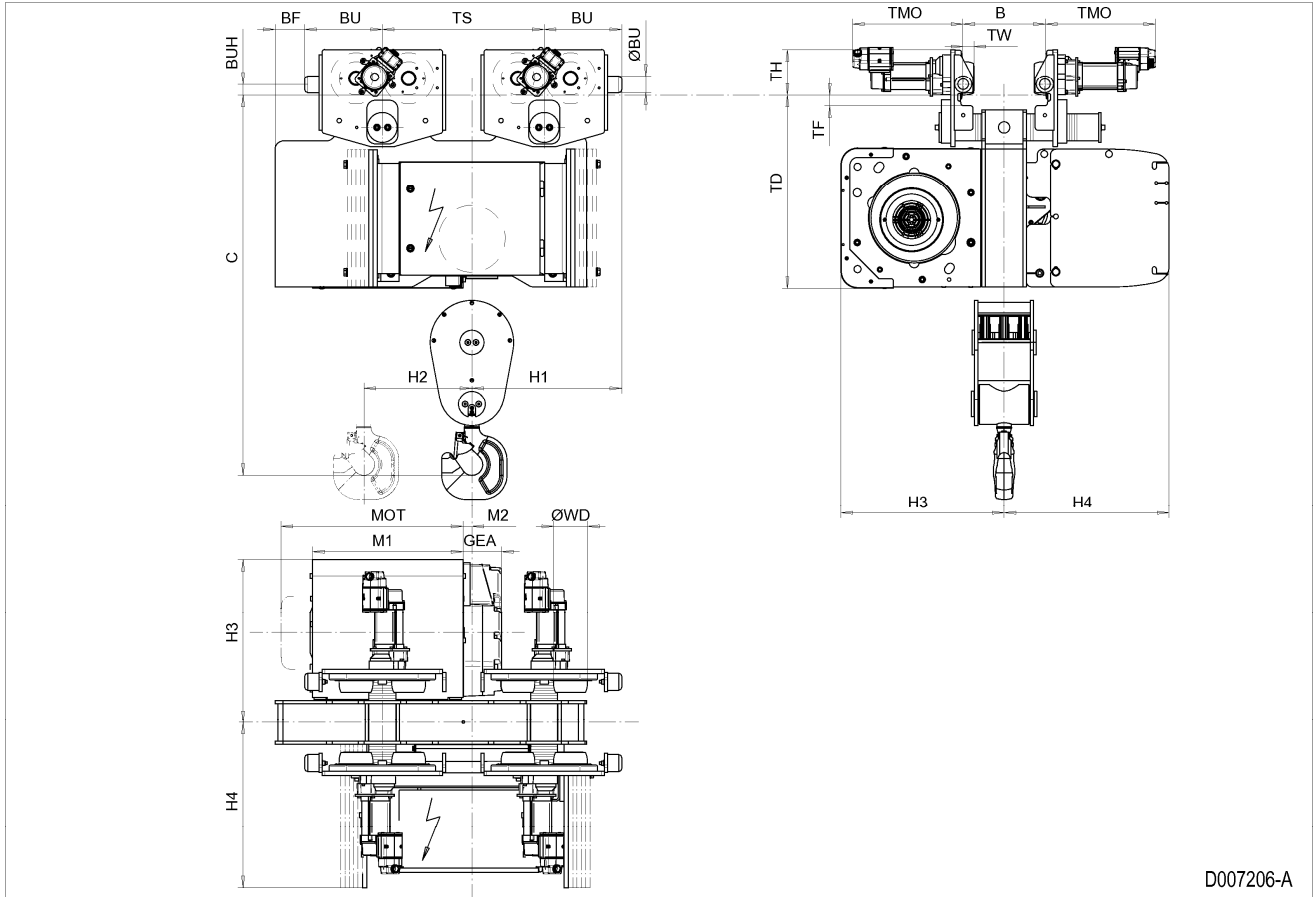

D007206-A

61 NORMAL HEADROOM HOIST ND, REEVING: 06, CURVED TRACK

Hoist dimensions

HOL m	Length code	M1 mm	H1 mm	H2 mm	H3 mm	H3* mm	Weight kg
6	D	558	556	53	605	625	1110
8	E	678	556	78	605	625	1155
10	F	828	596	98	605	625	1245
13	G	1018	596	132	605	625	1300

Motor dimensions

Motor	P5	P6	P7	A5	S5	S7
MOT (mm)	578	578	618	498	606	757
Weight (kg)	58	85	105	45	53	81

Travelling dimensions

Motor	MF06MA	MF06LA
TMO (mm)	360	400
Weight (kg)	5.7	7.8

Trolley dimensions

B min	B max	C	ØBU	ØWD	R min	BU	BUH	GEA	H4	M2	TD
120	300	1568	63	125	2500	288	40	143	612	33	871
TF	TH	TW									
39.5	170	41.5									

D007207_A
124579

Trolley dimensions

Length code	BF	TS
D/E	110	600
F/G	370	720

Note: All dimensions in mm.

Note: Weight calculated with P5 motor.

* Please, disregard the dimension H3*.

Normal Headroom Hoist ND, REEVING: 06, Curved Track

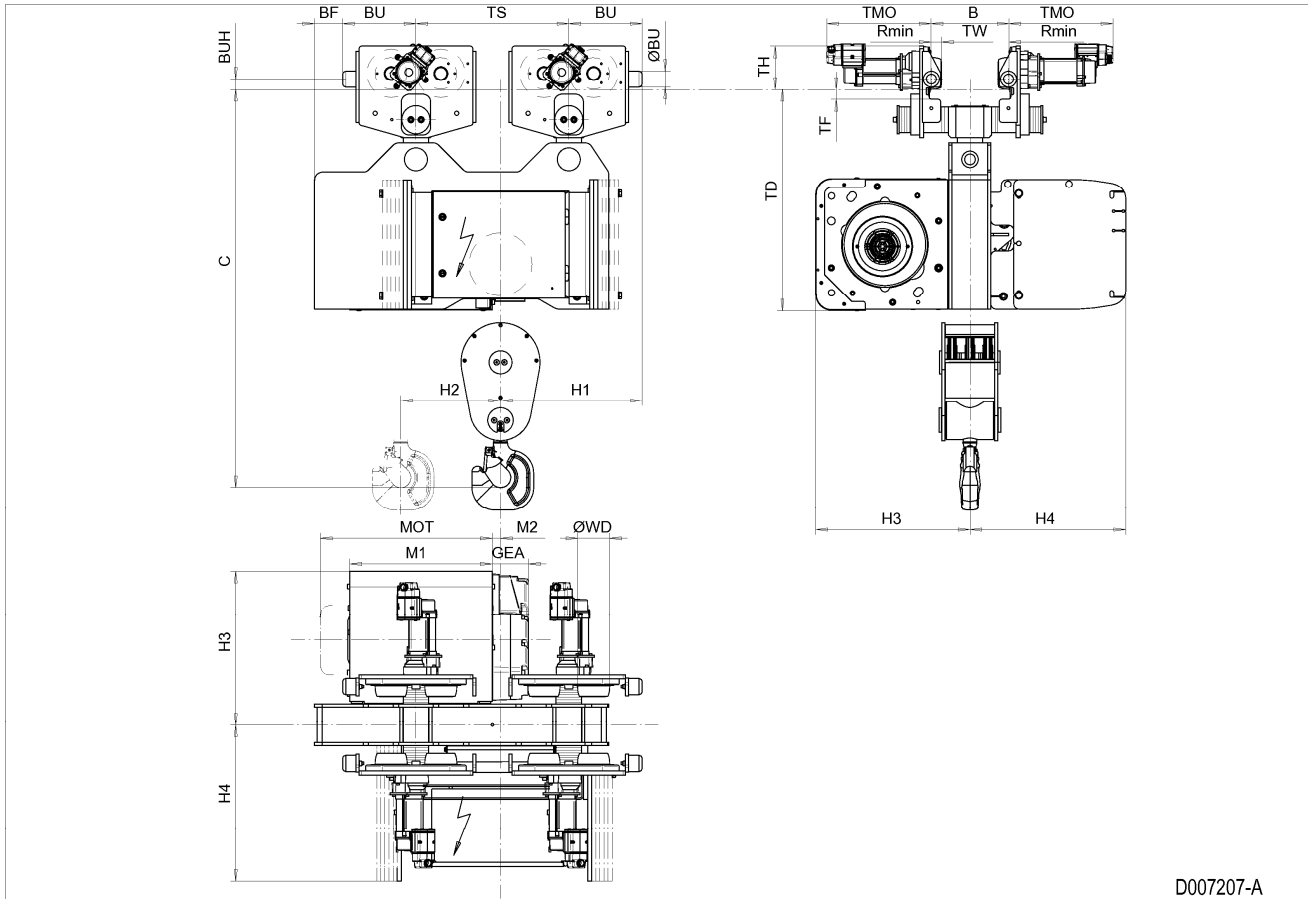

D007207-A

62 NORMAL HEADROOM HOIST ND, REEVING: 08

Hoist dimensions

HOL m	Length code	M1 mm	H1 mm	H2 mm	H3 mm	H3* mm	Weight kg
4.5	D	558	556	44	605	625	1040
6	E	678	556	53	605	625	1060
8	F	828	596	76	605	625	1150
10	G	1018	596	98	605	625	1210

Motor dimensions

Motor	P5	P6	P7	A5	S5	S7
MOT (mm)	578	578	618	498	606	757
Weight (kg)	58	85	105	45	53	81

Travelling dimensions

Motor	MF06MA	MF06LA
TMO (mm)	360	400
Weight (kg)	5.7	7.8

Trolley dimensions

B min	B max	C	ØBU	ØWD	BU	BUH	GEA	H4	M2	TD	TF
110	610	1413	63	125	288	40	143	612	33	716	39.5
TH	TW										
170	41.5										

D007208_A
124580

Trolley dimensions

Length code	BF	TS
D/E	110	600
F/G	370	720

Note: All dimensions in mm.

Note: Weight calculated with P5 motor, when B=300 mm.

* Please, disregard the dimension H3*.

Normal Headroom Hoist ND, REEVING: 08

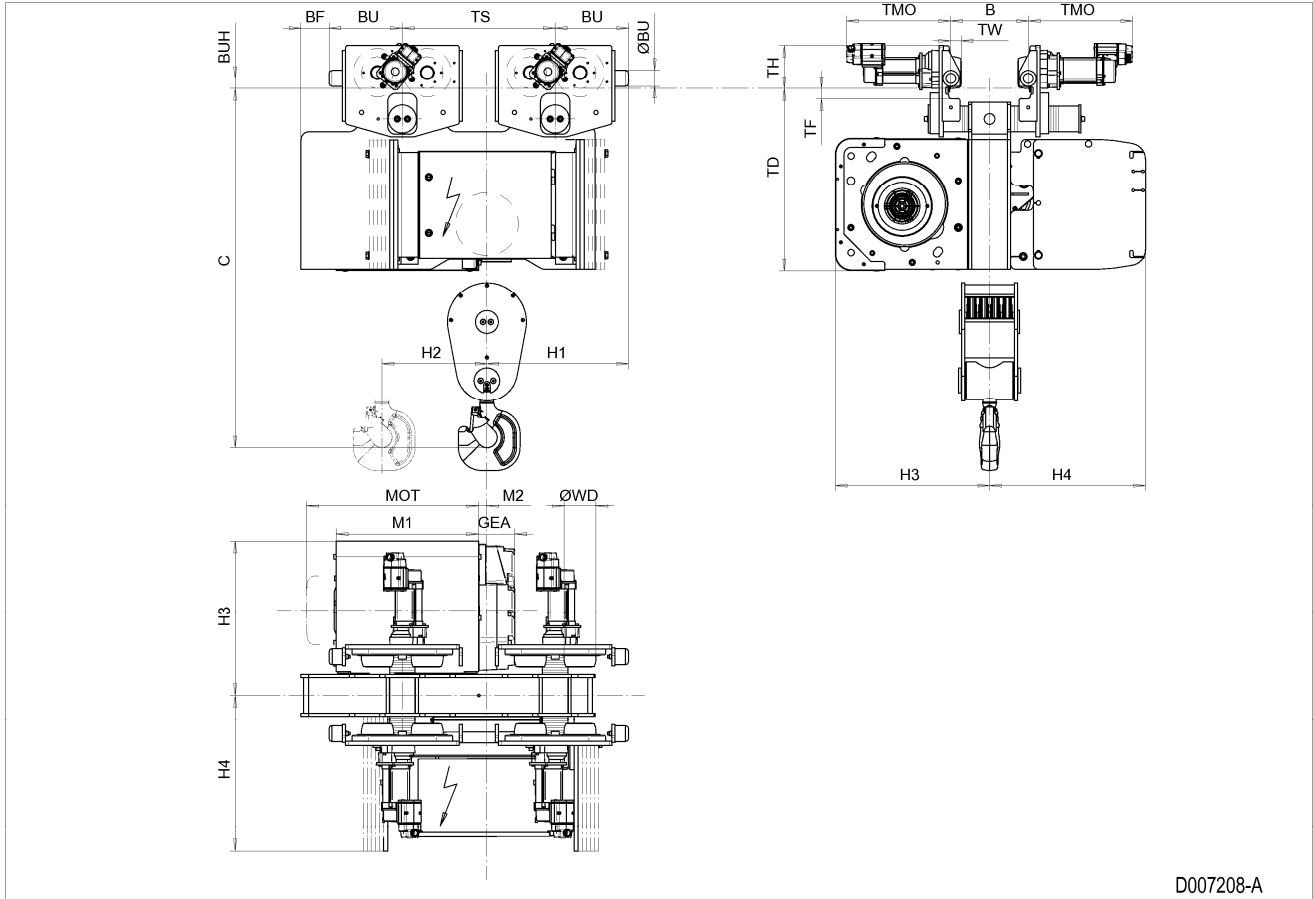

D007208-A

63 NORMAL HEADROOM HOIST ND, REEVING: 08, CURVED TRACK

Hoist dimensions

HOL m	Length code	M1 mm	H1 mm	H2 mm	H3 mm	H3* mm	Weight kg
4.5	D	558	556	44	605	625	1120
6	E	678	556	53	605	625	1170
8	F	828	596	76	605	625	1260
10	G	1018	596	98	605	625	1315

Motor dimensions

Motor	P5	P6	P7	A5	S5	S7
MOT (mm)	578	578	618	498	606	757
Weight (kg)	58	85	105	45	53	81

Travelling dimensions

Motor	MF06MA	MF06LA
TMO (mm)	360	400
Weight (kg)	5.7	7.8

Trolley dimensions

B min	B max	C	ØBU	ØWD	R min	BU	BUH	GEA	H4	M2	TD
120	300	1568	63	125	2500	288	40	143	612	33	716
TF	TH	TW									
39.5	170	41.5									

D007209_A
124581

Trolley dimensions

Length code	BF	TS
D/E	110	600
F/G	370	720

Note: All dimensions in mm.

Note: Weight calculated with P5 motor.

* Please, disregard the dimension H3*.

Normal Headroom Hoist ND, REEVING: 08, Curved Track

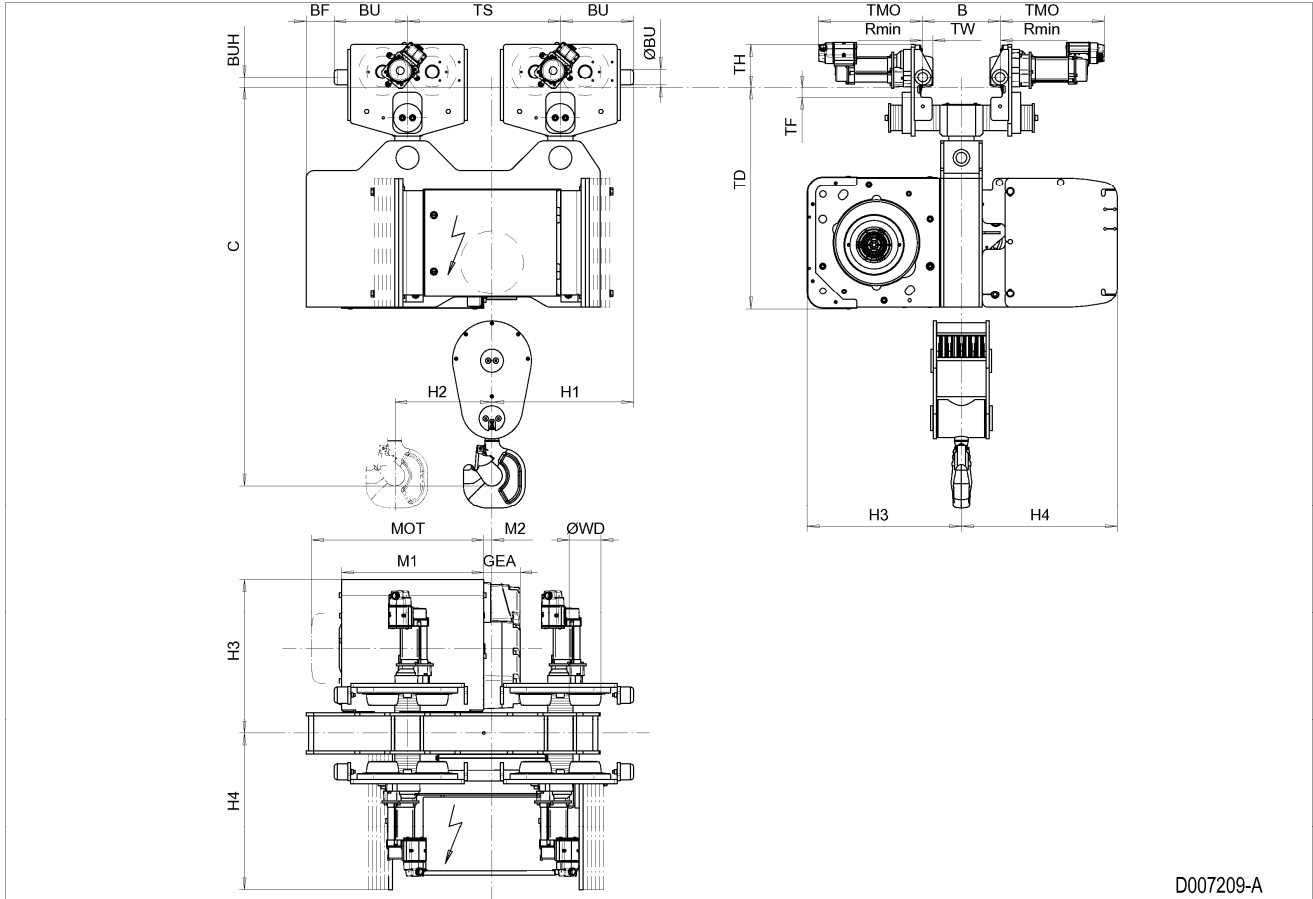

64 NORMAL HEADROOM HOIST ND, REEVING: 22

Hoist dimensions

HOL m	Length code	M1 mm	M2 mm	BRA mm	H1 mm	H3 mm	H3* mm	Weight kg
8.5	D	558	279	-	553	595	615	870
13	E	678	339	-	553	595	615	890
18	F	828	414	-	553	595	615	940
25	G	1018	509	-	753	595	615	1085
33.5	H	1268	634	128	753	595	615	1160
46	J	1618	809	128	753	595	615	1245

Motor dimensions

Motor	P5	P6	P7	A5	S5	S7
MOT (mm)	578	578	618	498	606	757
Weight (kg)	58	85	105	45	53	81

Travelling dimensions

Motor	MF06MA	MF06LA
TMO (mm)	360	400
Weight (kg)	5.7	7.8

Trolley dimensions

B min	B max	C	ØBU	ØWD	BU	BUH	GEA	H4	TD	TF	TH
90	610	1200	63	100	253	40	143	602	676	35	150
TW											
33											

D007219_A
124936

Trolley dimensions

Length code	BF	TS
D/E/F	113	300
G/H/J	-77	500

Note: All dimensions in mm.

Note: Weight calculated with P5, when B=300 mm.

Note: Gear brake as standard brake for drum lengths H and J.

* Please, disregard the dimension H3*.

Normal Headroom Hoist ND, REEVING: 22

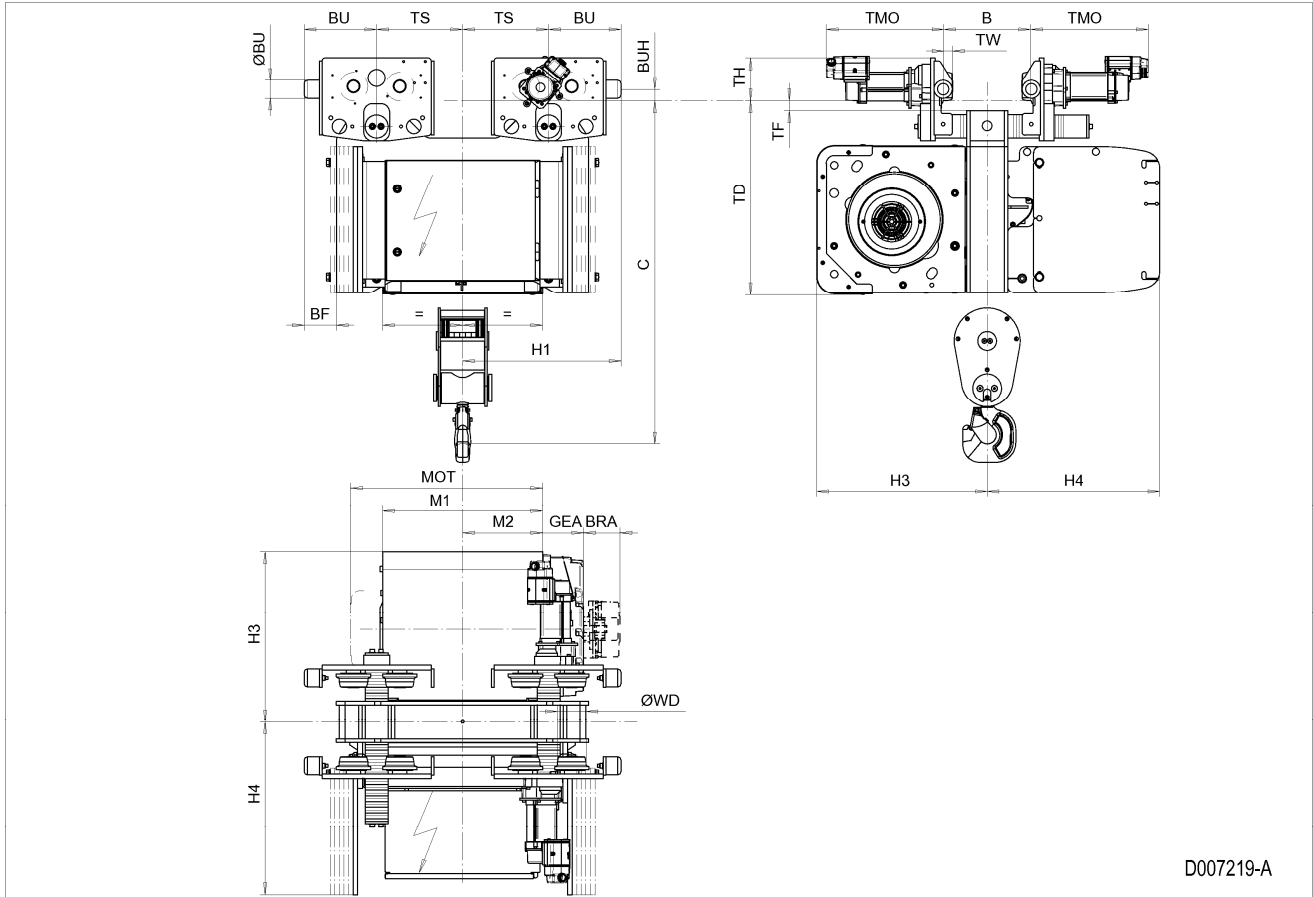

D007219-A

65 NORMAL HEADROOM HOIST ND, REEVING: 22, CURVED TRACK

Hoist dimensions

HOL m	Length code	M1 mm	M2 mm	BRA mm	H1 mm	H3 mm	H3* mm	Weight kg
8.5	D	558	279	-	553	595	615	890
13	E	678	339	-	553	595	615	945
18	F	828	414	-	553	595	615	1000
25	G	1018	509	-	753	595	615	1145
33.5	H	1268	634	128	753	595	615	1215
46	J	1618	809	128	753	595	615	1330

Motor dimensions

Motor	P5	P6	P7	A5	S5	S7
MOT (mm)	578	578	618	498	606	757
Weight (kg)	58	85	105	45	53	81

Travelling dimensions

Motor	MF06MA	MF06LA
TMO (mm)	360	400
Weight (kg)	5.7	7.8

Trolley dimensions

B min	B max	C	ØBU	ØWD	BU	BUH	GEA	H4	TD	TF	TH
90	350	1353	63	100	253	40	143	602	829	42	150
TW											
30.5											

D007220_A
124937

Track radius

B	R min
90 - 109	2500
110 - 119	2000
120 - 350	1500

Trolley dimensions

Length code	BF	TS
D/E/F	113	300
G/H/J	-77	500

Note: All dimensions in mm.

Note: Weight calculated with P5 motor.

Note: Gear brake as standard brake for drum lengths H and J.

* Please, disregard the dimension H3*.

Normal Headroom Hoist ND, REEVING: 22, Curved Track

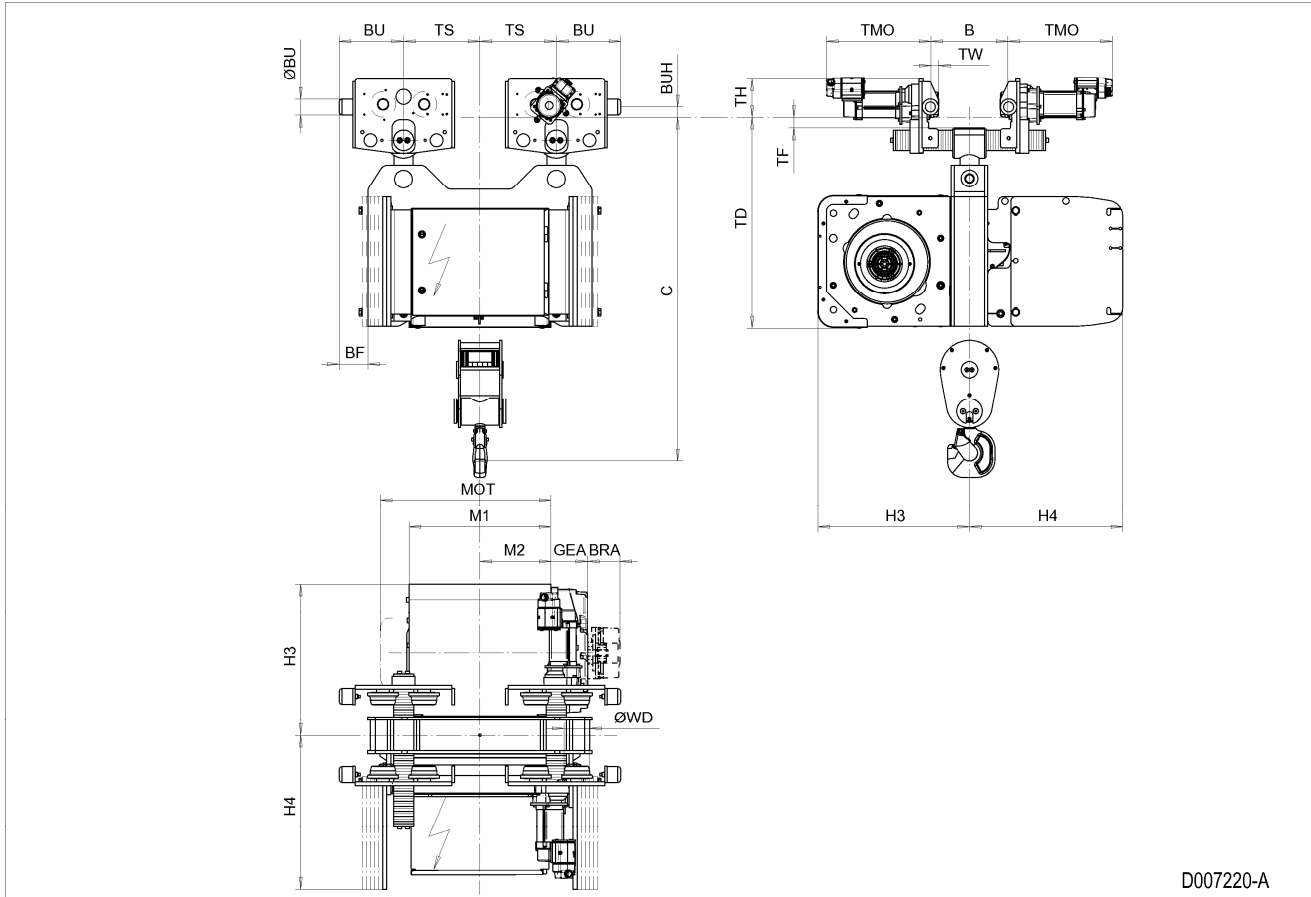

66 NORMAL HEADROOM HOIST ND, REEVING: 24

Hoist dimensions

HOL m	Length code	M1 mm	M2 mm	BRA mm	H1 mm	H3 mm	H3* mm	Weight kg
4	D	558	279	-	553	595	615	950
6.5	E	678	339	-	553	595	615	970
9	F	828	414	-	553	595	615	1020
12.5	G	1018	509	-	753	595	615	1165
16.5	H	1268	634	128	753	595	615	1240
23	J	1618	809	128	753	595	615	1325

Motor dimensions

Motor	P5	P6	P7	A5	S5	S7
MOT (mm)	578	578	618	498	606	757
Weight (kg)	58	85	105	45	53	81

Travelling dimensions

Motor	MF06MA	MF06LA
TMO (mm)	360	400
Weight (kg)	5.7	7.8

Trolley dimensions

B min	B max	C	ØBU	ØWD	BU	BUH	GEA	H4	TD	TF	TH
90	610	1365	63	100	253	40	143	602	676	35	150
TW											
31											

D007221_A
124938

Trolley dimensions

Length code	BF	TS
D/E/F	113	300
G/H/J	-77	500

Note: All dimensions in mm.

Note: Weight calculated with P5 motor, when B=300 mm.

Note: Gear brake as standard brake for drum lengths H and J.

* Please, disregard the dimension H3*.

Normal Headroom Hoist ND, REEVING: 24

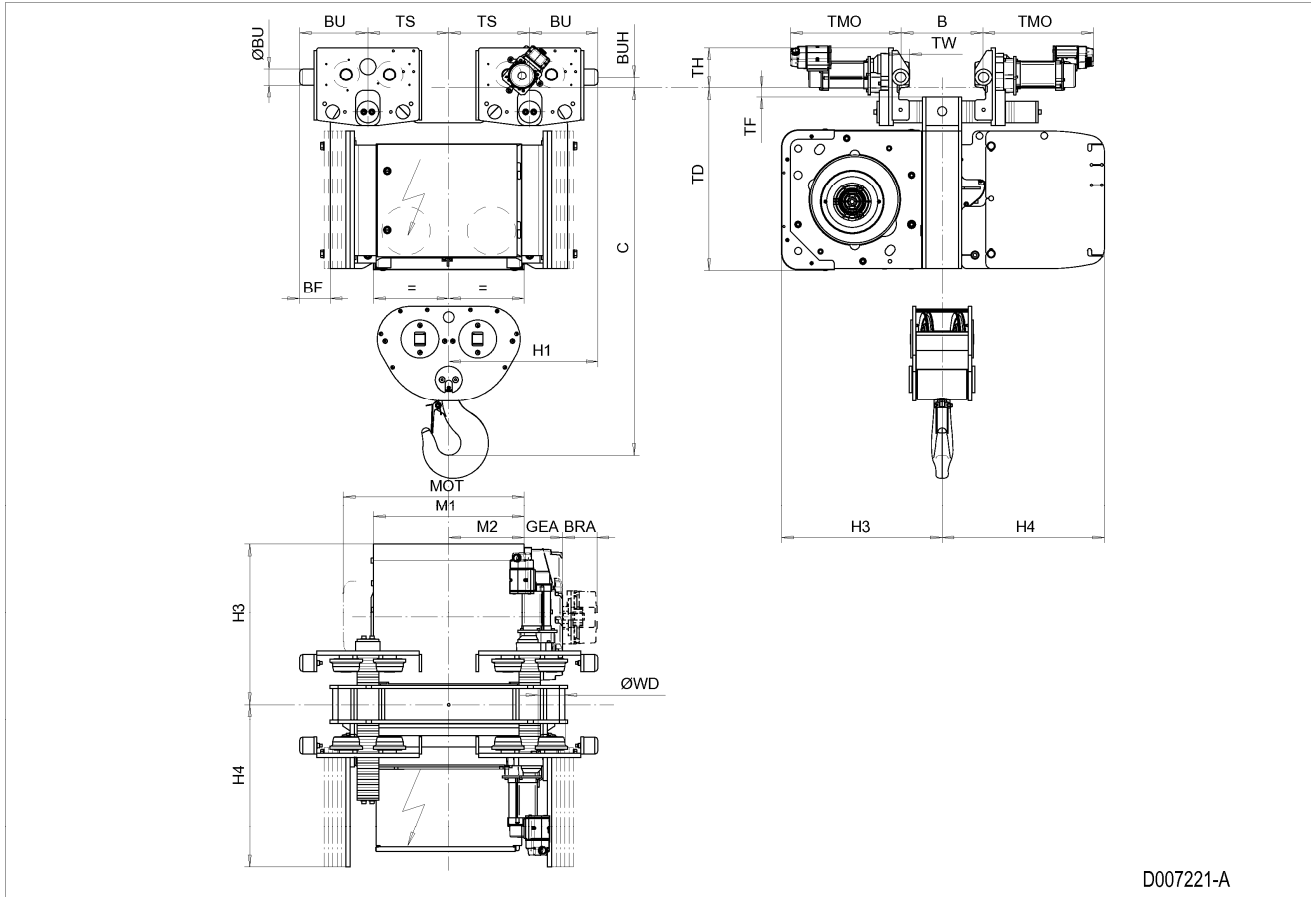

67 NORMAL HEADROOM HOIST ND, REEVING: 24, CURVED TRACK

Hoist dimensions

HOL m	Length code	M1 mm	M2 mm	BRA mm	H1 mm	H3 mm	H3* mm	Weight kg
4	D	558	279	-	553	595	615	980
6.5	E	678	339	-	553	595	615	1025
9	F	828	414	-	553	595	615	1075
12.5	G	1018	509	-	753	595	615	1220
16.5	H	1268	634	128	753	595	615	1295
23	J	1618	809	128	753	595	615	1405

Motor dimensions

Motor	P5	P6	P7	A5	S5	S7
MOT (mm)	578	578	618	498	606	757
Weight (kg)	58	85	105	45	53	81

Travelling dimensions

Motor	MF06MA	MF06LA
TMO (mm)	360	400
Weight (kg)	5.7	7.8

Trolley dimensions

B min	B max	C	ØBU	ØWD	BU	BUH	GEA	H4	TD	TF	TH
90	350	1518	63	100	253	40	143	602	829	42	150
TW											
31											

D007222_A
124939

Track radius

B	R min
90 - 109	2500
110 - 119	2000
120 - 350	1500

Trolley dimensions

Length code	BF	TS
D/E/F	113	300
G/H/J	-77	500

Note: All dimensions in mm.

Note: Weight calculated with P5 motor.

Note: Gear brake as standard brake for drum lengths H and J.

* Please, disregard the dimension H3*.

Normal Headroom Hoist ND, REEVING: 24, Curved Track

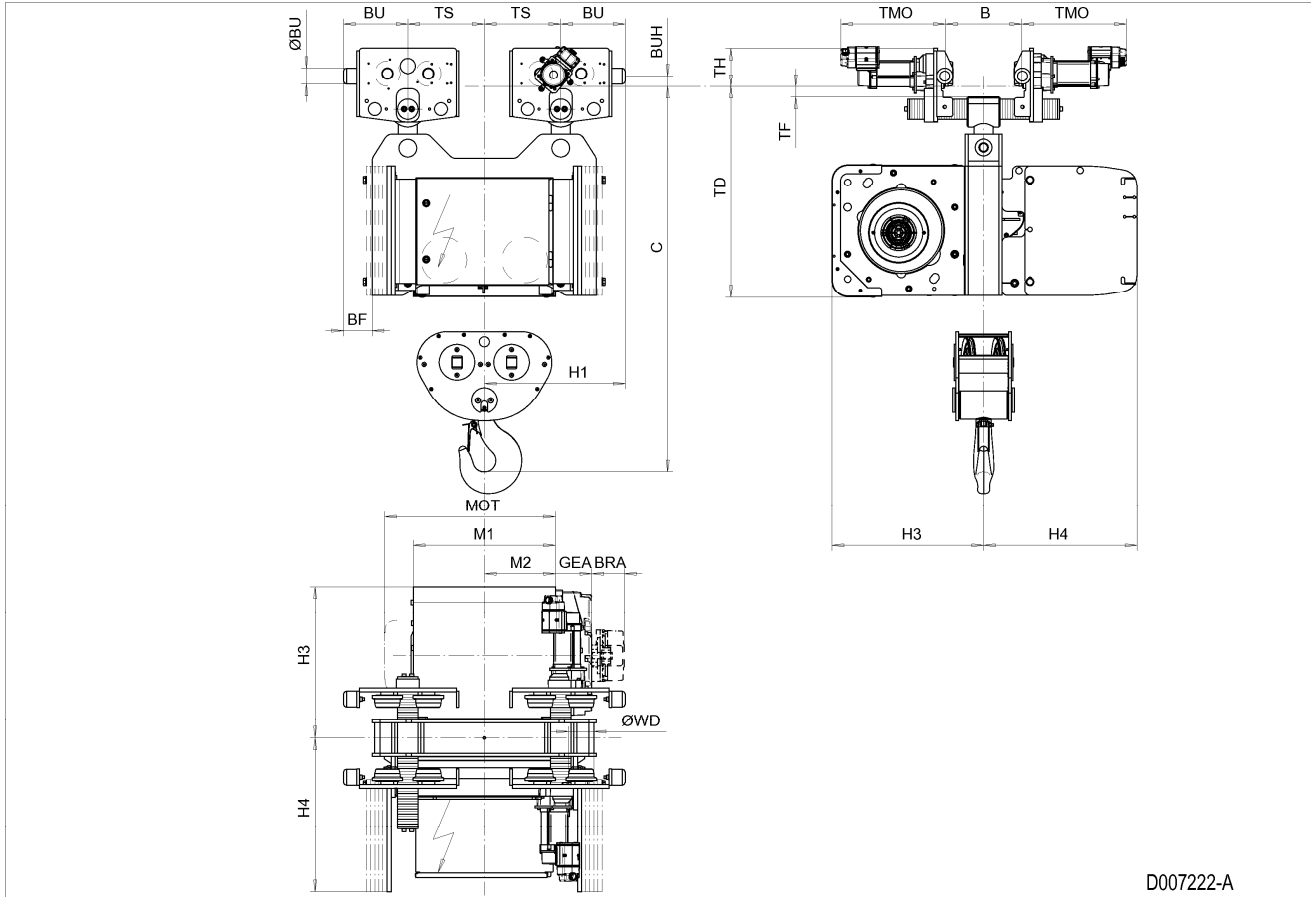

D007222-A

68 NORMAL HEADROOM HOIST ND, REEVING: 26

Hoist dimensions

HOL m	Length code	M1 mm	M2 mm	BRA mm	H1 mm	H3 mm	H3* mm	Weight kg
4	E	678	339	-	588	595	615	990
6	F	828	414	-	588	595	615	1010
8	G	1018	509	-	788	595	615	1060
11	H	1268	634	128	788	595	615	1205
15	J	1618	809	128	788	595	615	1280

Motor dimensions

Motor	P5	P6	P7	A5	S5	S7
MOT (mm)	578	578	618	498	606	757
Weight (kg)	58	85	105	45	53	81

Travelling dimensions

Motor	MF06MA	MF06LA
TMO (mm)	360	400
Weight (kg)	5.7	7.8

Trolley dimensions

B min	B max	C	ØBU	ØWD	BU	BUH	GEA	H4	TD	TF	TH
100	610	1408	63	125	288	40	143	602	716	40	170
TW											
41.5											

D007223_A
124940

Trolley dimensions

Length code	BF	TS
E/F	148	300
G/H/J	-42	500

Note: All dimensions in mm.

Note: Weight calculated with P5 motor, when B=300 mm.

Note: gear brake as standard brake for drum lengths H and J.

* Please, disregard the dimension H3*.

Normal Headroom Hoist ND, REEVING: 26

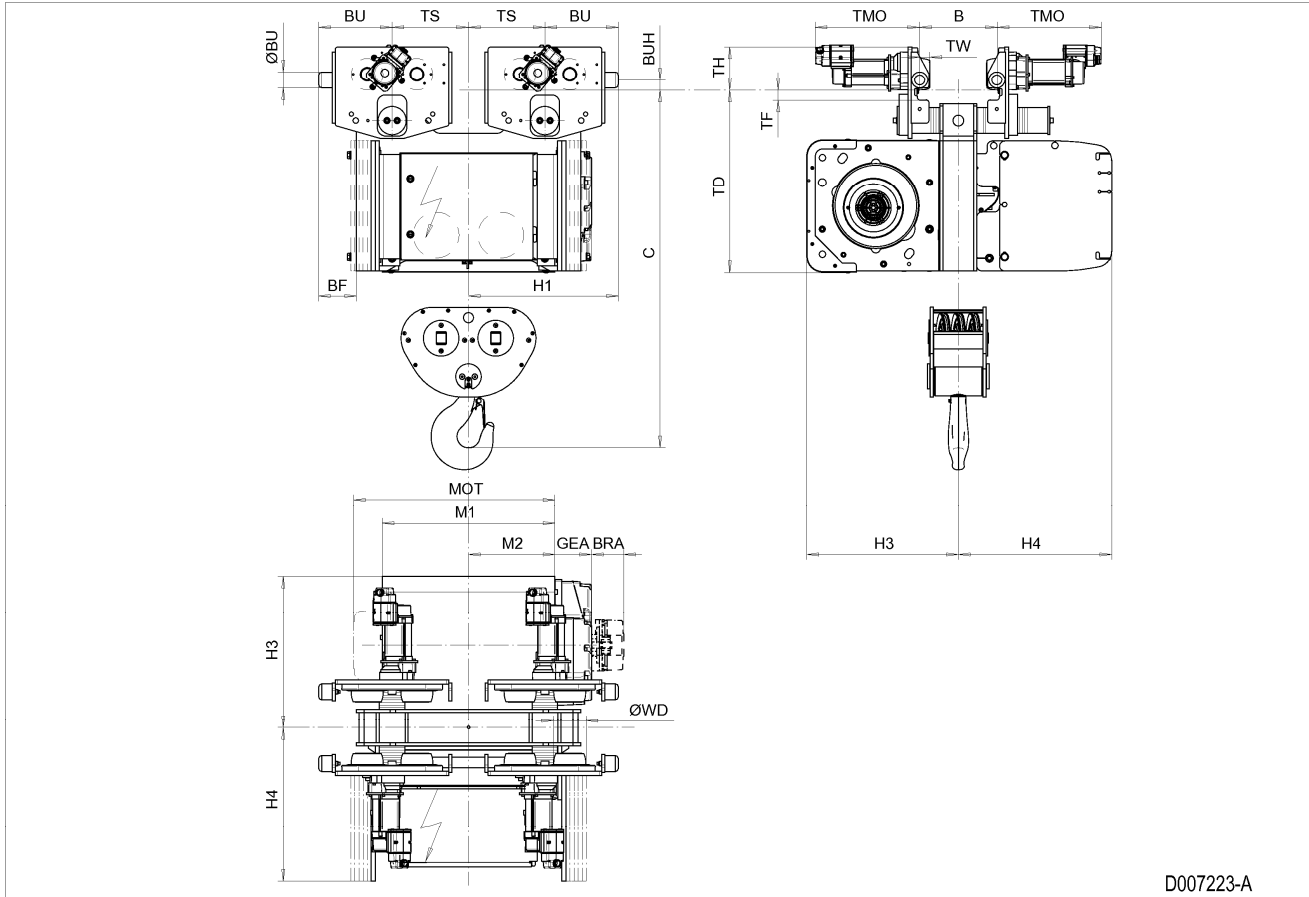

D007223-A

69 NORMAL HEADROOM HOIST ND, REEVING: 26, CURVED TRACK

Hoist dimensions

HOL m	Length code	M1 mm	M2 mm	BRA mm	H1 mm	H3 mm	H3* mm	Weight kg
4	E	678	339	-	588	595	615	1115
6	F	828	414	-	588	595	615	1165
8	G	1018	509	-	788	595	615	1310
11	H	1268	634	128	788	595	615	1385
15	J	1618	809	128	788	595	615	1495

Motor dimensions

Motor	P5	P6	P7	A5	S5	S7
MOT (mm)	578	578	618	498	606	757
Weight (kg)	58	85	105	45	53	81

Travelling dimensions

Motor	MF06MA	MF06LA
TMO (mm)	360	400
Weight (kg)	5.7	7.8

Trolley dimensions

B min	B max	C	ØBU	ØWD	R min	BU	BUH	GEA	H4	TD	TF
120	300	1563	63	125	2500	288	40	143	602	871	40
TH	TW										
170	41.5										

D007224_A
124941

Trolley dimensions

Length code	BF	TS
E/F	148	300
G/H/J	-42	500

Note: All dimensions in mm.

Note: Weight calculated with P5 motor.

Note: Gear brake as standard brake for drum lengths H and J.

* Please, disregard the dimension H3*.

Normal Headroom Hoist ND, REEVING: 26, Curved Track

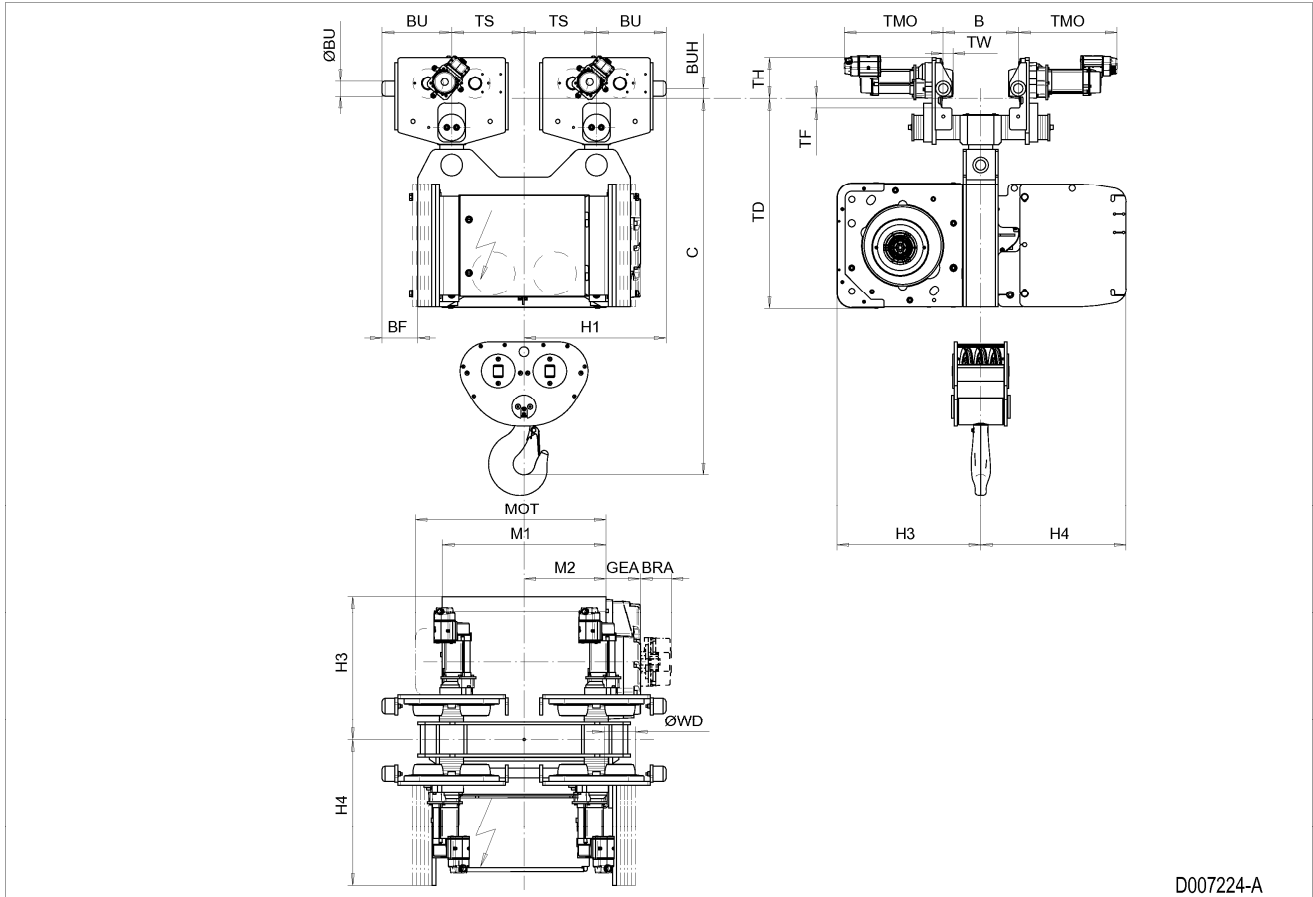

D007224-A

70 NORMAL HEADROOM HOIST ND, REEVING: 28

Hoist dimensions

HOL m	Length code	M1 mm	M2 mm	BRA mm	H1 mm	H3 mm	H3* mm	Weight kg
4.5	F	828	414	-	588	595	615	1075
6	G	1018	509	-	788	595	615	1220
8	H	1268	634	128	788	595	615	1295
11.5	J	1618	809	128	788	595	615	1380

Motor dimensions

Motor	P5	P6	P7	A5	S5	S7
MOT (mm)	578	578	618	498	606	757
Weight (kg)	58	85	105	45	53	81

Travelling dimensions

Motor	MF06MA	MF06LA
TMO (mm)	360	400
Weight (kg)	5.7	7.8

Trolley dimensions

B min	B max	C	ØBU	ØWD	BU	BUH	GEA	H4	TD	TF	TH
100	610	1408	63	125	288	40	143	602	716	40	170
TW											
41.5											

D007225_A
124942

Trolley dimensions

Length code	BF	TS
F	148	300
G/H/J	-42	500

Note: All dimensions in mm.

Note: Weight calculated with P5 motor, when B=300 mm.

Note: Gear brake as standard brake for drum lengths H and J.

* Please, disregard the dimension H3*.

Normal Headroom Hoist ND, REEVING: 28

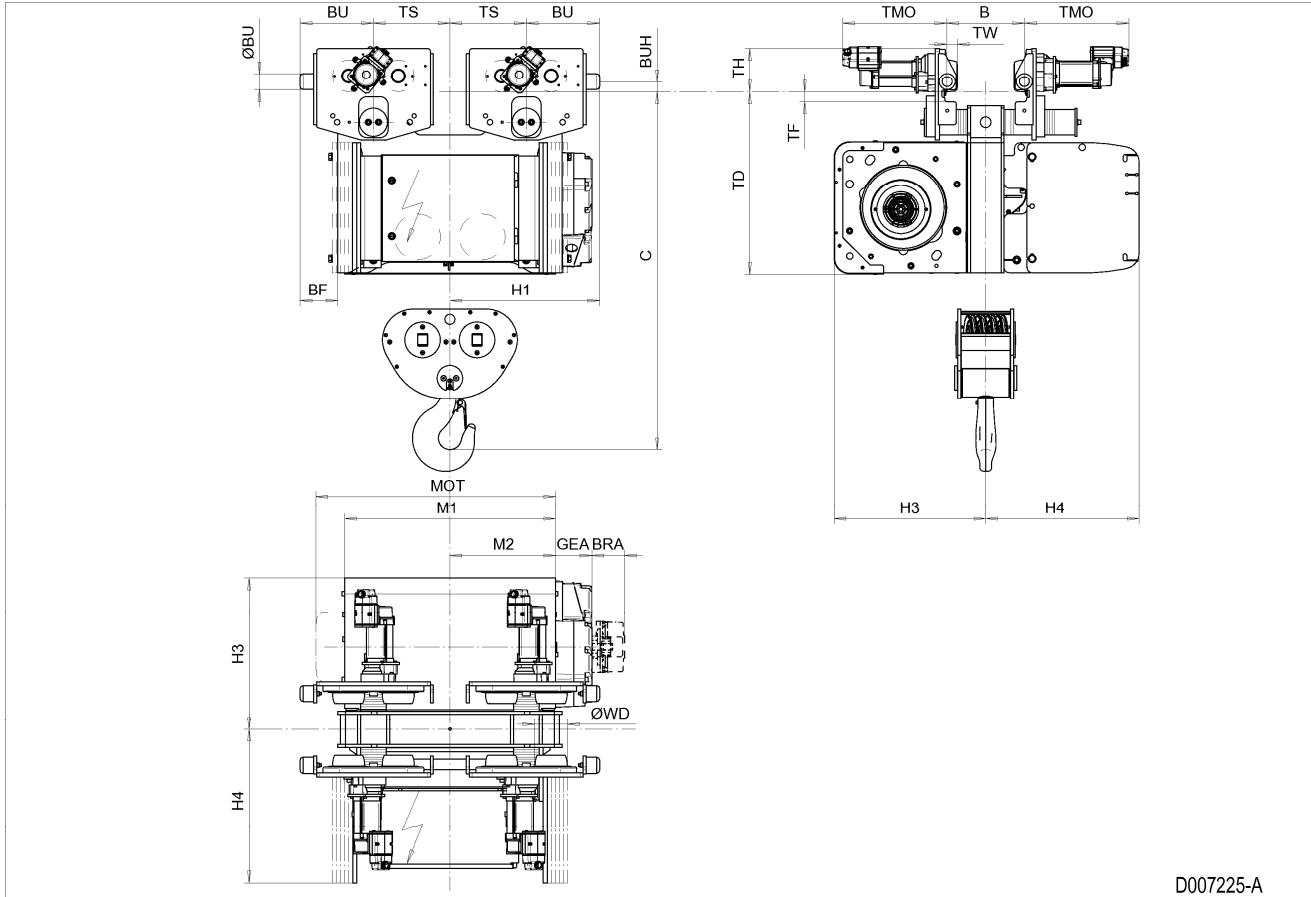

71 NORMAL HEADROOM HOIST ND, REEVING: 28, CURVED TRACK

Hoist dimensions

HOL m	Length code	M1 mm	M2 mm	BRA mm	H1 mm	H3 mm	H3* mm	Weight kg
4.5	F	828	414	-	588	595	615	1180
6	G	1018	509	-	788	595	615	1325
8	H	1268	634	128	788	595	615	1400
11.5	J	1618	809	128	788	595	615	1510

Motor dimensions

Motor	P5	P6	P7	A5	S5	S7
MOT (mm)	578	578	618	498	606	757
Weight (kg)	58	85	105	45	53	81

Travelling dimensions

Motor	MF06MA	MF06LA
TMO (mm)	360	400
Weight (kg)	5.7	7.8

Trolley dimensions

B min	B max	C	ØBU	ØWD	R min	BU	BUH	GEA	H4	TD	TF
120	300	1563	63	125	2500	288	40	143	602	871	40
TH	TW										
170	41.5										

D007226_A
124943

Trolley dimensions

Length code	BF	TS
F	148	300
G/H/J	-42	500

Note: All dimensions in mm.

Note: Weight calculated with P5 motor.

Note: Gear brake as standard brake for drum lengths H and J.

* Please, disregard the dimension H3*.

Normal Headroom Hoist ND, REEVING: 28, Curved Track

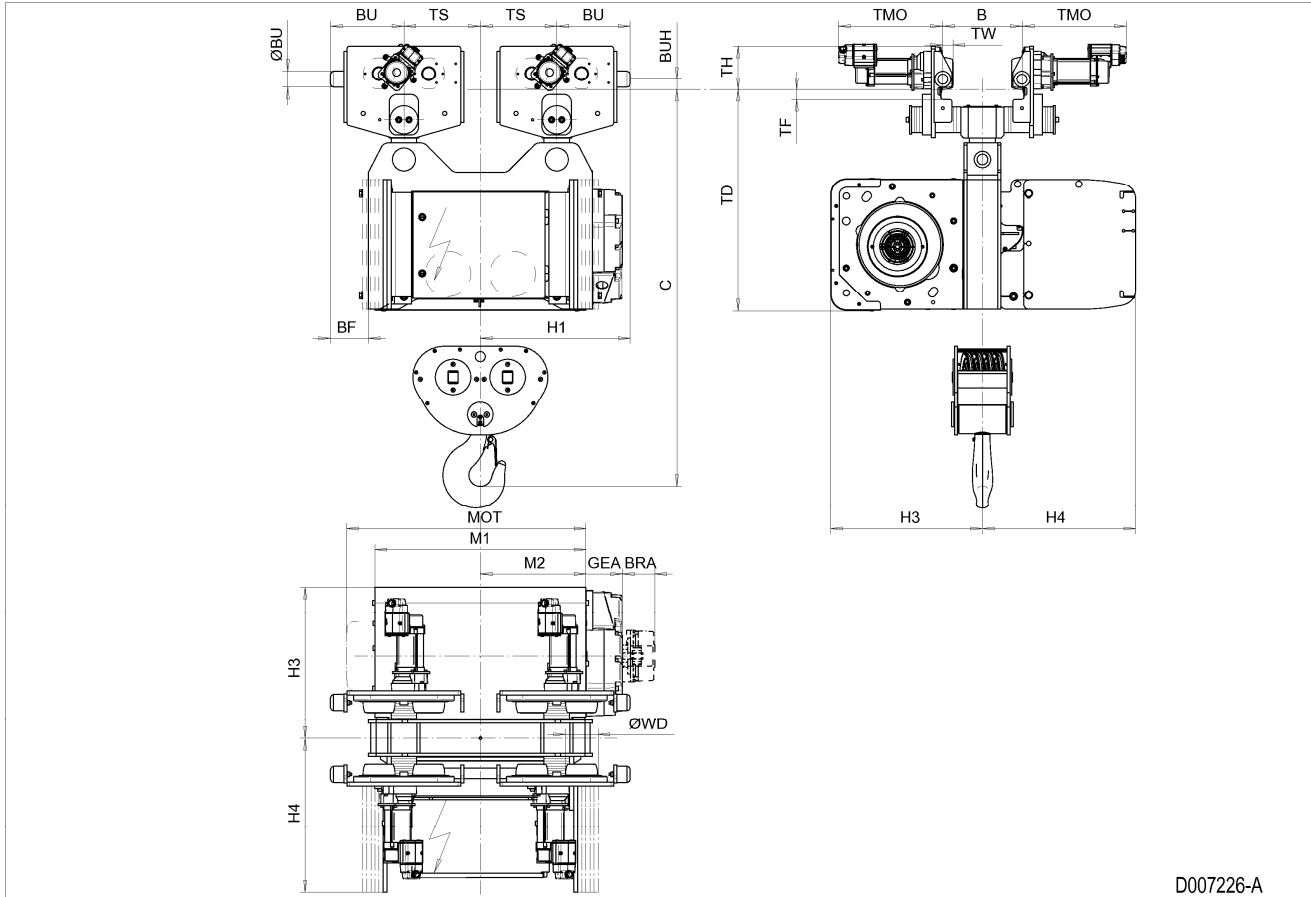

D007226-A

72 NORMAL HEADROOM HOIST NE, REEVING: 02

Hoist dimensions

HOL	HOL*	Length Code	E11	M1	M2	TS	BF	H1	H2	Weight A**	Weight B**
m	m		mm	mm	mm	mm	mm	mm	mm	kg	kg
15.5	10	C	605	462	610	1310	88	838	139	2000	2200
21	15.5	D	605	562	610	1310	88	838	188	2000	2300
28	22.5	E	605	682	560	1540	88	788	251	2200	2400
36	30.5	F	605	832	560	1540	88	788	322	2300	2500
47	41.5	G	605	1022	640	2050	88	868	421	2500	2700
61	55.5	H	605	1272	640	2050	88	868	546	2700	2900
80.5	75	J	1064	1622	600	1910	-371	828	721	3100	3400
97	91.5	K	1064	1922	600	1910	-371	828	868	3300	3600

*HOL with drum brake

**Presence of a drum brake will increase weight by 80 kgs.

Motor dimensions

Motor	P6	P7	P8	A7	S7	S8	SA
MOT (mm)	536	576	711	536	715	763	803
Weight (kg)	85	105	106	71	81	97	120

Travelling dimensions

Motor	MF06LA
TMO (mm)	400
Weight (kg)	7.8

Trolley dimensions

B1 min	B1 max	B2 min	B2 max	C	ØBU	ØWD	Min R	BU	BUH	E1	E2
120	610	180	320	1752	63	125	2500	288	40	605	959
E3	GEA	H3	H4	M3	TD	TF	TH	TW			
126	218	871	756	44	998	35	170	41.5			

D006985_A

103527

Note: All dimensions in mm.

Note: Weight calculated with P6 motor when B=300 mm.

Note: Dimensions B1 min, B1 max and Weight A for normal track suspension.

Note: Dimensions B2 min, B2 max, Weight B and Min R for curved track suspension (option).

Normal Headroom Hoist NE, REEVING: 02

Electric panel size for hoists with Crane electric provisions

Trolley travel control type	2-speed --or-- MicroDrive	TravelMaster 3 power rating 002	TravelMaster 3 power ratings 003-004	TravelMaster 3 power ratings 005-007	TravelMaster 2p power ratings 002-005	TravelMaster 2p power ratings 007-011
Electric panel size + additional panel size Main voltage 400V or 460V	600x600	600x600	1000x600	600x600*	600x600 + 600x400	600x600*
Electric panel size + additional panel size Other main voltages	1000x600	1000x600	1000x600 + 600x400	600x600*	600x600*	600x600*

* Inverter in bridge panel.

Electric panel size for hoists with Solo electric provisions

Trolley travel control type	2-speed --or-- MicroDrive	TravelMaster 3 power rating 002	TravelMaster 3 power ratings 003-004	TravelMaster 3 power ratings 005-007	TravelMaster 2p power ratings 002-005	TravelMaster 2p power ratings 007-011
Electric panel size + additional panel size Main voltage 400V or 460V	1000x600	1000x600	1000x600	1000x600 + 1000x600	1000x600 + 600x400	1000x600 + 1000x600
Electric panel size + additional panel size Other main voltages	1000x600	1000x600	1000x600 + 600x400	1000x600 + 1000x600**	1000x600 + 600x400	1000x600 + 1000x600**

**Transformer in bridge panel.

Note: For hoists with Solo electric provisions and a hoisting inverter, a special cubicle layout is required. Please consult the factory.

Note: Detail view A for normal track suspension. Detail view B for curved track suspension (option).

Note: X points the location for an auxiliary electrical cubicle.

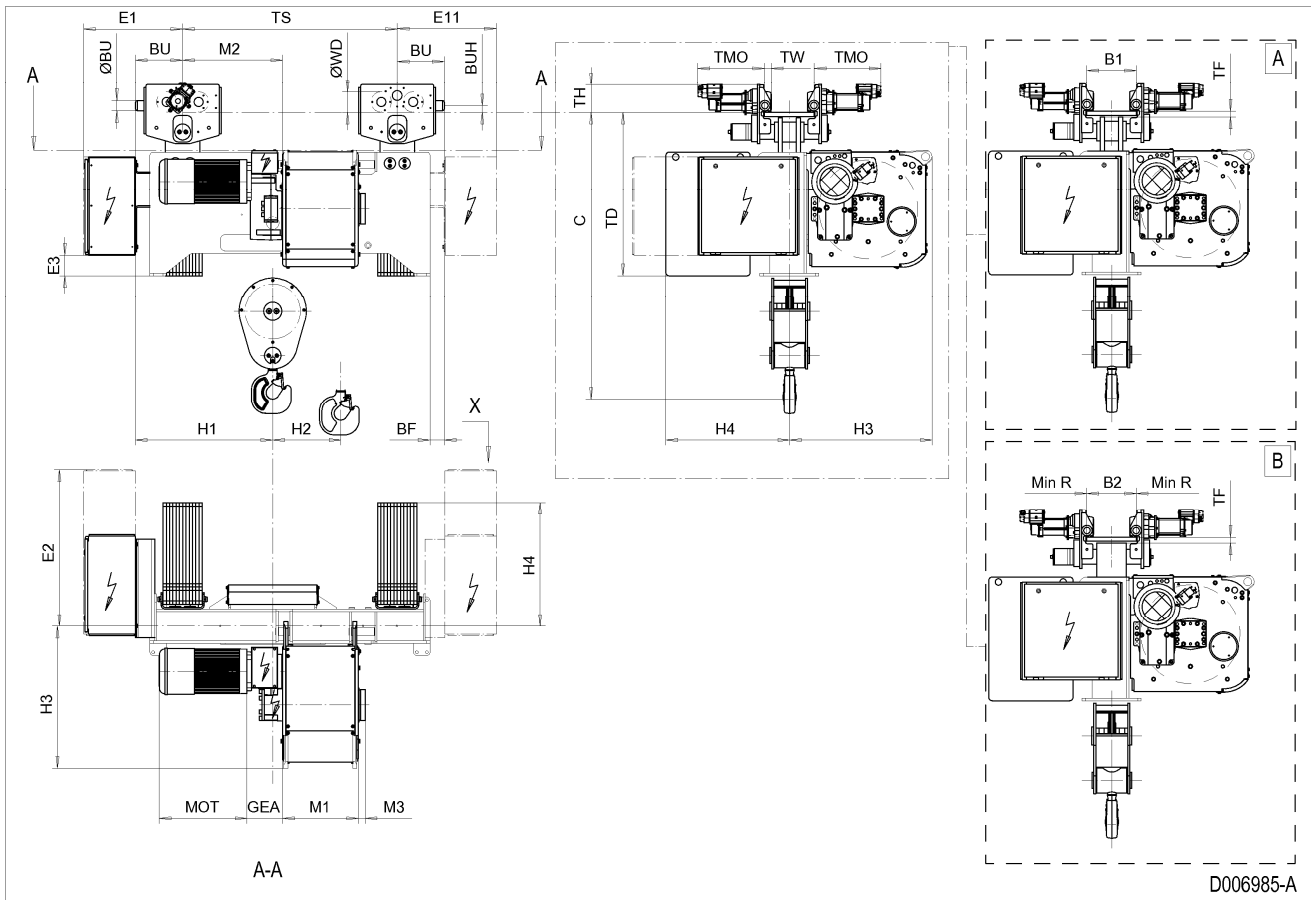

73 NORMAL HEADROOM HOIST NE, REEVING: 04

Hoist dimensions

HOL	HOL*	Length Code	E11	M1	M2	TS	BF	H1	H2	Weight A**	Weight B**
m	m		mm	mm	mm	mm	mm	mm	mm	kg	kg
7.5	4.5	C	605	462	610	1310	165	915	69	2300	2500
10.5	7.5	D	605	562	610	1310	165	915	94	2300	2600
14	11	E	1085	682	560	1060	-315	865	125	2500	2700
18	15	F	1085	832	560	1060	-315	865	161	2600	2800
23.5	20.5	G	1255	1022	640	1400	-485	945	210	2800	3000
30.5	27.5	H	1255	1272	640	1400	-485	945	273	3000	3200
40	37	J	1574	1622	600	1400	-804	905	360	3400	3600
48.5	45.5	K	1574	1922	600	1400	-804	905	434	3600	3900

*HOL with drum brake

**Presence of a drum brake will increase weight by 80 kgs.

Motor dimensions

Motor	P6	P7	P8	A7	S7	S8	SA
MOT (mm)	536	576	711	536	715	763	803
Weight (kg)	85	105	106	71	81	97	120

Travelling dimensions

Motor	MF06LA
TMO (mm)	431
Weight (kg)	7.8

Trolley dimensions

B1 min	B1 max	B2 min	B2 max	C	ØBU	ØWD	Min R	BU	BUH	E1	E2
130	610	180	320	1762	80	180	4000	365	53	605	959
E3	GEA	H3	H4	M3	TD	TF	TH	TW			
126	218	871	756	44	1008	45	208	53			

D006986_A

103528

Note: All dimensions in mm.

Note: Weight calculated with P6 motor when B=300 mm.

Note: Dimensions B1 min, B1 max and Weight A for normal track suspension.

Note: Dimensions B2 min, B2 max, Weight B and Min R for curved track suspension (option).

Normal Headroom Hoist NE, REEVING: 04

Electric panel size for hoists with Crane electric provisions

Trolley travel control type	2-speed --or-- MicroDrive	TravelMaster 3 power rating 002	TravelMaster 3 power ratings 003-004	TravelMaster 3 power ratings 005-007	TravelMaster 2p power ratings 002-005	TravelMaster 2p power ratings 007-011
Electric panel size + additional panel size Main voltage 400V or 460V	600x600	600x600	1000x600	600x600*	600x600 + 600x400	600x600*
Electric panel size + additional panel size Other main voltages	1000x600	1000x600	1000x600 + 600x400	600x600*	600x600*	600x600*

* Inverter in bridge panel.

Electric panel size for hoists with Solo electric provisions

Trolley travel control type	2-speed --or-- MicroDrive	TravelMaster 3 power rating 002	TravelMaster 3 power ratings 003-004	TravelMaster 3 power ratings 005-007	TravelMaster 2p power ratings 002-005	TravelMaster 2p power ratings 007-011
Electric panel size + additional panel size Main voltage 400V or 460V	1000x600	1000x600	1000x600	1000x600 + 1000x600	1000x600 + 600x400	1000x600 + 1000x600
Electric panel size + additional panel size Other main voltages	1000x600	1000x600	1000x600 + 600x400	1000x600 + 1000x600**	1000x600 + 600x400	1000x600 + 1000x600**

**Transformer in bridge panel.

Note: For hoists with Solo electric provisions and a hoisting inverter, a special cubicle layout is required. Please consult the factory.

Note: Detail view A for normal track suspension. Detail view B for curved track suspension (option).

Note: X points the location for an auxiliary electrical cubicle.

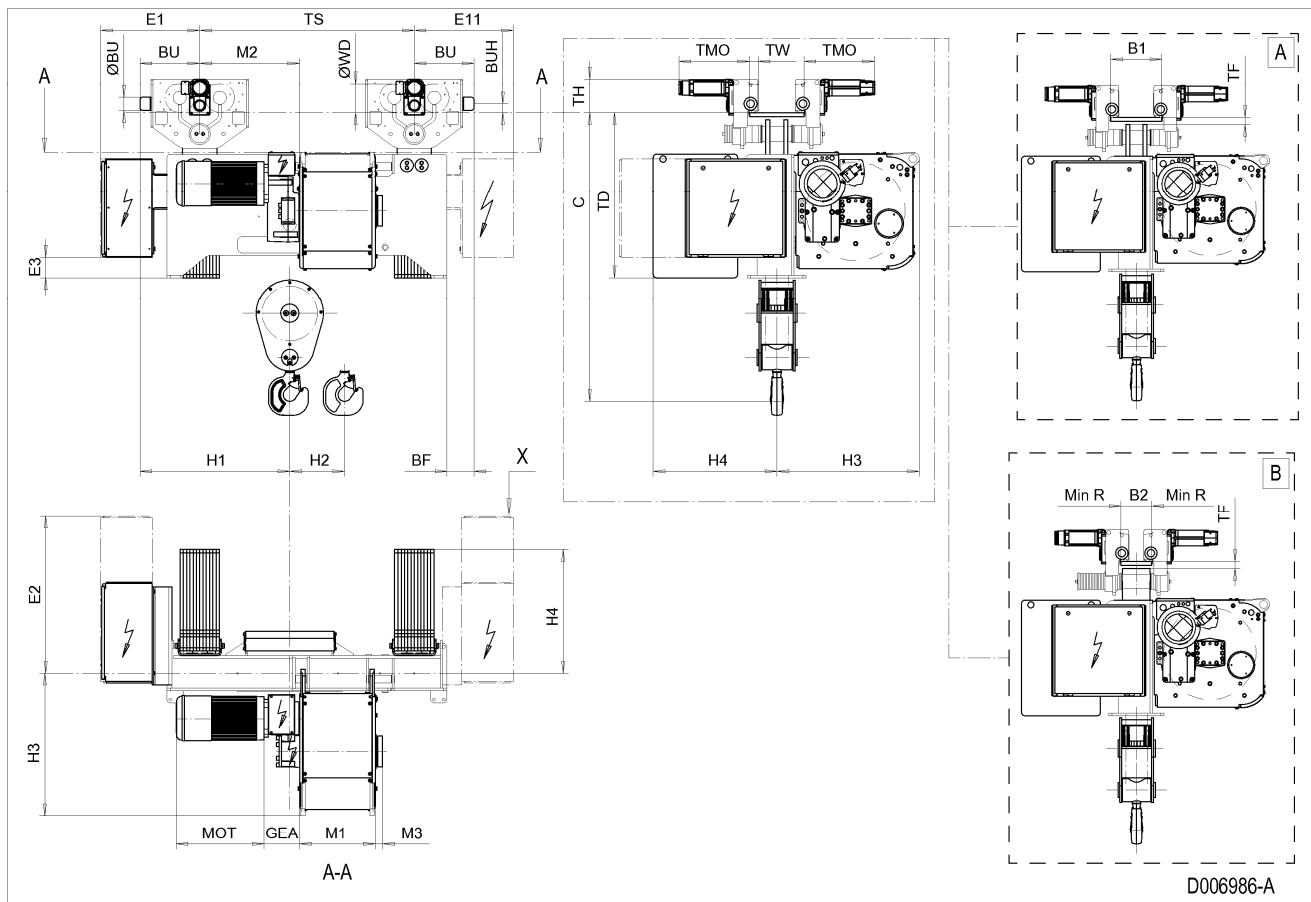

74 NORMAL HEADROOM HOIST NE, REEVING: 06

Hoist dimensions

HOL	HOL*	Length Code	E11	M1	M2	TS	BF	H1	H2	Weight A**	Weight B**
m	m		mm	mm	mm	mm	mm	mm	mm	kg	kg
5	3	C	605	462	610	1310	165	915	46	2400	2600
7	5	D	605	562	610	1310	165	915	63	2400	2700
9	7	E	1085	682	560	1060	-315	865	84	2600	2800
12	10	F	1085	832	560	1060	-315	865	107	2700	2900
15.5	13.5	G	1255	1022	640	1400	-485	945	140	2900	3100
20	18	H	1255	1272	640	1400	-485	945	182	3100	3300
26.5	24.5	J	1574	1622	600	1400	-804	905	240	3500	3700
32	30	K	1574	1922	600	1400	-804	905	289	3700	4000

*HOL with drum brake

**Presence of a drum brake will increase weight by 80 kgs.

Motor dimensions

Motor	P6	P7	P8	A7	S7	S8	SA
MOT (mm)	536	576	711	536	715	763	803
Weight (kg)	85	105	106	71	81	97	120

Travelling dimensions

Motor	MF06LA
TMO (mm)	431
Weight (kg)	7.8

Trolley dimensions

B1 min	B1 max	B2 min	B2 max	C	ØBU	ØWD	Min R	BU	BUH	E1	E2
130	610	180	320	1881	80	180	4000	365	53	605	959
E3	GEA	H3	H4	M3	TD	TF	TH	TW			
126	218	871	756	44	1008	45	208	53			

D006987_A

103529

Note: All dimensions in mm.

Note: Weight calculated with P6 motor when B=300 mm.

Note: Dimensions B1 min, B1 max and Weight A for normal track suspension.

Note: Dimensions B2 min, B2 max, Weight B and Min R for curved track suspension (option).

Normal Headroom Hoist NE, REEVING: 06

Electric panel size for hoists with Crane electric provisions

Trolley travel control type	2-speed --or-- MicroDrive	TravelMaster 3 power rating 002	TravelMaster 3 power ratings 003-004	TravelMaster 3 power ratings 005-007	TravelMaster 2p power ratings 002-005	TravelMaster 2p power ratings 007-011
Electric panel size + additional panel size Main voltage 400V or 460V	600x600	600x600	1000x600	600x600*	600x600 + 600x400	600x600*
Electric panel size + additional panel size Other main voltages	1000x600	1000x600	1000x600 + 600x400	600x600*	600x600*	600x600*

* Inverter in bridge panel.

Electric panel size for hoists with Solo electric provisions

Trolley travel control type	2-speed --or-- MicroDrive	TravelMaster 3 power rating 002	TravelMaster 3 power ratings 003-004	TravelMaster 3 power ratings 005-007	TravelMaster 2p power ratings 002-005	TravelMaster 2p power ratings 007-011
Electric panel size + additional panel size Main voltage 400V or 460V	1000x600	1000x600	1000x600	1000x600 + 1000x600	1000x600 + 600x400	1000x600 + 1000x600
Electric panel size + additional panel size Other main voltages	1000x600	1000x600	1000x600 + 600x400	1000x600 + 1000x600**	1000x600 + 600x400	1000x600 + 1000x600**

**Transformer in bridge panel.

Note: For hoists with Solo electric provisions and a hoisting inverter, a special cubicle layout is required. Please consult the factory.

Note: Detail view A for normal track suspension. Detail view B for curved track suspension (option).

Note: X points the location for an auxiliary electrical cubicle.

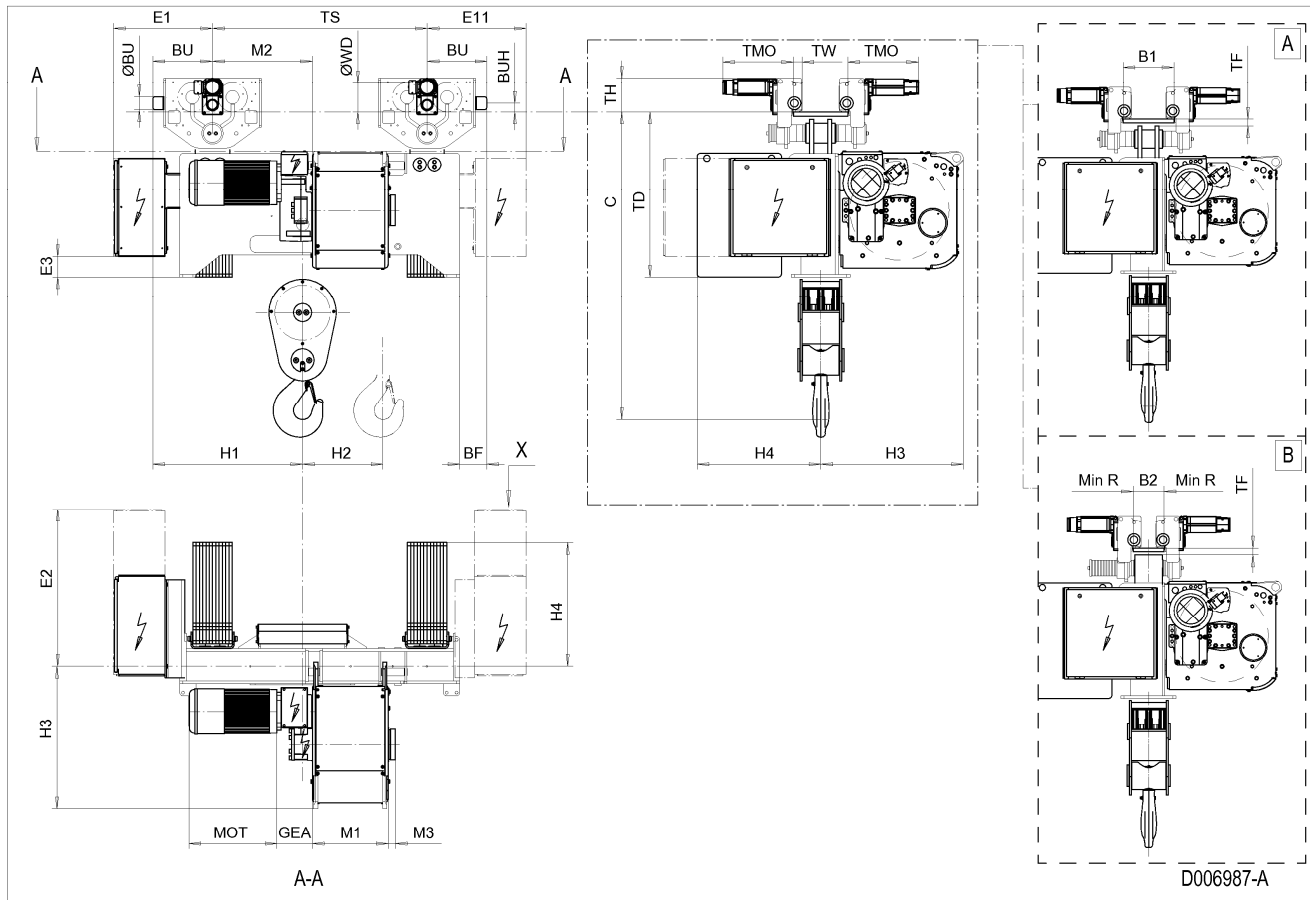

75 NORMAL HEADROOM HOIST NE, REEVING: 22

Hoist dimensions

HOL m	HOL* m	Length code	E1 mm	M1 mm	M2 mm	TS mm	BF mm	Weight A** kg	Weight B** kg
16.5	9	E	605	682	314	655	93	2000	2200
22	14.5	F	605	832	239	655	93	2100	2300
29.5	22	G	605	1022	144	655	93	2300	2500
39	31.5	H	605	1272	319	955	93	2500	2800
52	44.5	J	605	1622	144	955	93	2800	3100
63.5	56	K	925	1922	-306	655	-227	3000	3300
77	69.5	L	925	2272	-481	655	-227	3300	3600
86.5	79	M	900	2522	-306	955	-202	3600	4000
98	90.5	N	900	2822	-456	955	-202	3800	4300

*HOL with drum brake

**Presence of a drum brake will increase weight by 80 kgs.

Motor dimensions

Motor	P6	P7	P8	A7	S7	S8	SA
MOT (mm)	536	576	711	536	715	763	803
Weight (kg)	85	105	106	71	81	97	120

Travelling dimensions

Motor	MF06LA
TMO (mm)	400
Weight (kg)	7.8

Trolley dimensions

B1 min	B1 max	B2 min	B2 max	C	ØBU	ØWD	Min R	BU	BUH	E2	E3
120	610	180	320	1667	63	125	2500	288	40	979	126
GEA	H3	H4	M3	TD	TF	TH	TW				
218	848	733	44	998	35	170	41.5				

D006895_A

101302

Note: All dimensions in mm.

Note: Weight calculated with P6 motor when B=300 mm.

Note: Dimensions B1 min, B1 max and Weight A for normal track suspension.

Note: Dimensions B2 min, B2 max, Weight B and Min R for curved track suspension (option).

Normal Headroom Hoist NE, REEVING: 22

Electric panel size for hoists with Crane electric provisions

Trolley travel control type	2-speed --or-- MicroDrive	TravelMaster 3 power rating 002	TravelMaster 3 power ratings 003-004	TravelMaster 3 power ratings 005-007	TravelMaster 2p power ratings 002-005	TravelMaster 2p power ratings 007-011
Electric panel size + additional panel size Main voltage 400V or 460V	600x600	600x600	1000x600	600x600*	600x600 + 600x400	600x600*
Electric panel size + additional panel size Other main voltages	1000x600	1000x600	1000x600 + 600x400	600x600*	600x600*	600x600*

* Inverter in bridge panel.

Electric panel size for hoists with Solo electric provisions

Trolley travel control type	2-speed --or-- MicroDrive	TravelMaster 3 power rating 002	TravelMaster 3 power ratings 003-004	TravelMaster 3 power ratings 005-007	TravelMaster 2p power ratings 002-005	TravelMaster 2p power ratings 007-011
Electric panel size + additional panel size Main voltage 400V or 460V	1000x600	1000x600	1000x600	1000x600 + 1000x600	1000x600 + 600x400	1000x600 + 1000x600
Electric panel size + additional panel size Other main voltages	1000x600	1000x600	1000x600 + 600x400	1000x600 + 1000x600**	1000x600 + 600x400	1000x600 + 1000x600**

**Transformer in bridge panel.

Note: For hoists with Solo electric provisions and a hoisting inverter, a special cubicle layout is required. Please consult the factory.

Note: Detail view A for normal track suspension. Detail view B for curved track suspension (option).

Note: X points the location for an auxiliary electrical cubicle.

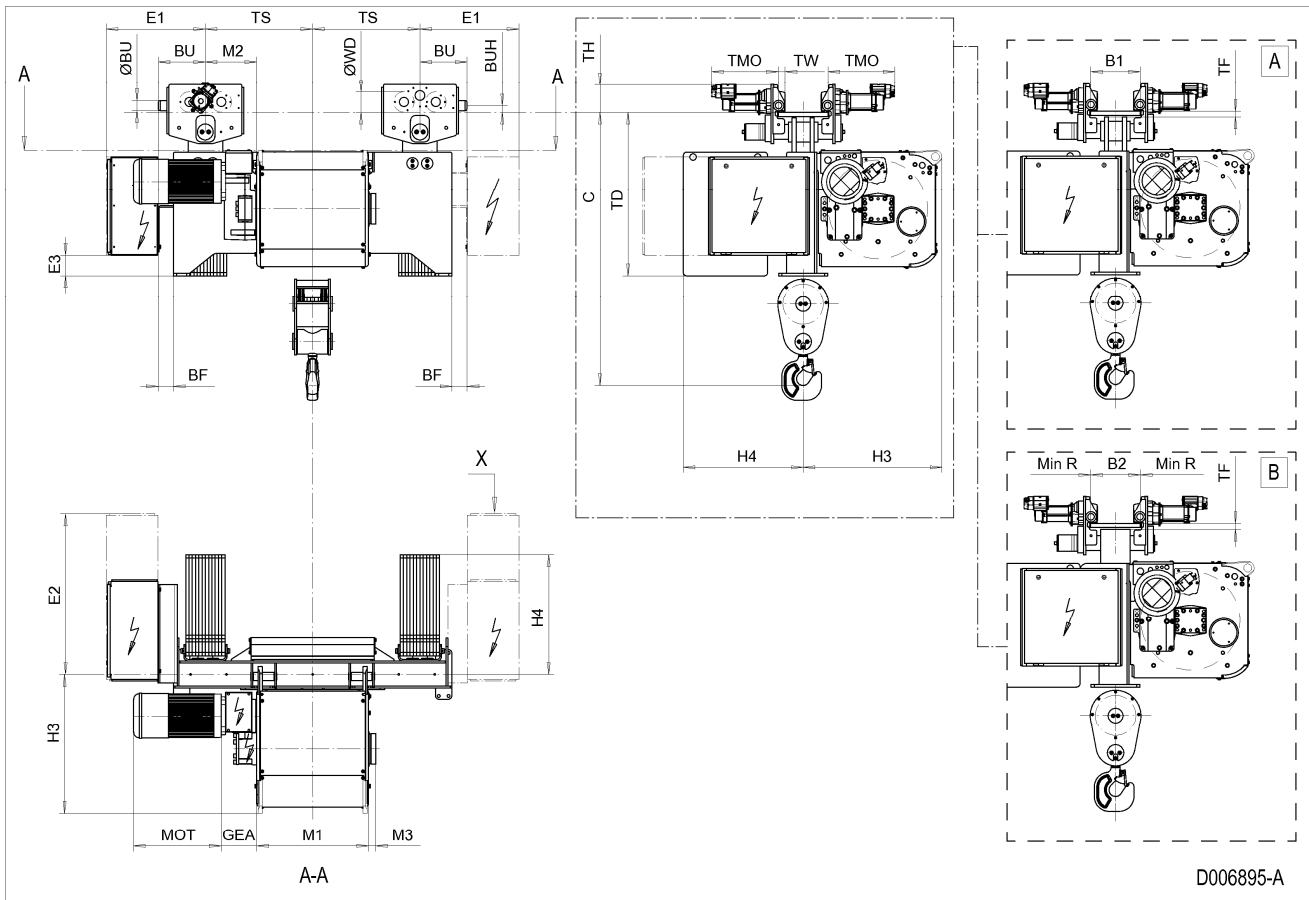

76 NORMAL HEADROOM HOIST NE, REEVING: 24

Hoist dimensions

HOL m	HOL* m	Length code	E1 mm	M1 mm	M2 mm	TS mm	BF mm	Weight A** kg	Weight B** kg
8	4	E	605	682	314	655	93	2100	2300
11	7	F	605	832	239	655	93	2200	2400
14.5	10.5	G	605	1022	144	655	93	2400	2600
19.5	15.5	H	605	1272	319	955	93	2600	2900
26	22	J	605	1622	144	955	93	2900	3100
31.5	27.5	K	925	1922	-306	655	-227	3100	3400
38.5	34.5	L	925	2272	-481	655	-227	3400	3700
43	39	M	900	2522	-306	955	-202	3700	4100
49	45	N	900	2822	-456	955	-202	3900	4300

*HOL with drum brake

**Presence of a drum brake will increase weight by 80 kgs.

Motor dimensions

Motor	P6	P7	P8	A7	S7	S8	SA
MOT (mm)	536	576	711	536	715	763	803
Weight (kg)	85	105	106	71	81	97	120

Travelling dimensions

Motor	MF06LA
TMO (mm)	400
Weight (kg)	7.8

Trolley dimensions

B1 min	B1 max	B2 min	B2 max	C	ØBU	ØWD	Min R	BU	BUH	E2	E3
120	610	180	320	1975	63	125	2500	288	40	979	126
GEA	H3	H4	M3	TD	TF	TH	TW				
218	848	733	44	998	35	170	41.5				

D006896_A

101303

Note: All dimensions in mm.

Note: Weight calculated with P6 motor when B=300 mm.

Note: Dimensions B1 min, B1 max and Weight A for normal track suspension.

Note: Dimensions B2 min, B2 max, Weight B and Min R for curved track suspension (option).

Normal Headroom Hoist NE, REEVING: 24

Electric panel size for hoists with Crane electric provisions

Trolley travel control type	2-speed --or-- MicroDrive	TravelMaster 3 power rating 002	TravelMaster 3 power ratings 003-004	TravelMaster 3 power ratings 005-007	TravelMaster 2p power ratings 002-005	TravelMaster 2p power ratings 007-011
Electric panel size + additional panel size Main voltage 400V or 460V	600x600	600x600	1000x600	600x600*	600x600 + 600x400	600x600*
Electric panel size + additional panel size Other main voltages	1000x600	1000x600	1000x600 + 600x400	600x600*	600x600*	600x600*

* Inverter in bridge panel.

Electric panel size for hoists with Solo electric provisions

Trolley travel control type	2-speed --or-- MicroDrive	TravelMaster 3 power rating 002	TravelMaster 3 power ratings 003-004	TravelMaster 3 power ratings 005-007	TravelMaster 2p power ratings 002-005	TravelMaster 2p power ratings 007-011
Electric panel size + additional panel size Main voltage 400V or 460V	1000x600	1000x600	1000x600	1000x600 + 1000x600	1000x600 + 600x400	1000x600 + 1000x600
Electric panel size + additional panel size Other main voltages	1000x600	1000x600	1000x600 + 600x400	1000x600 + 1000x600**	1000x600 + 600x400	1000x600 + 1000x600**

**Transformer in bridge panel.

Note: For hoists with Solo electric provisions and a hoisting inverter, a special cubicle layout is required. Please consult the factory.

Note: Detail view A for normal track suspension. Detail view B for curved track suspension (option).

Note: X points the location for an auxiliary electrical cubicle.

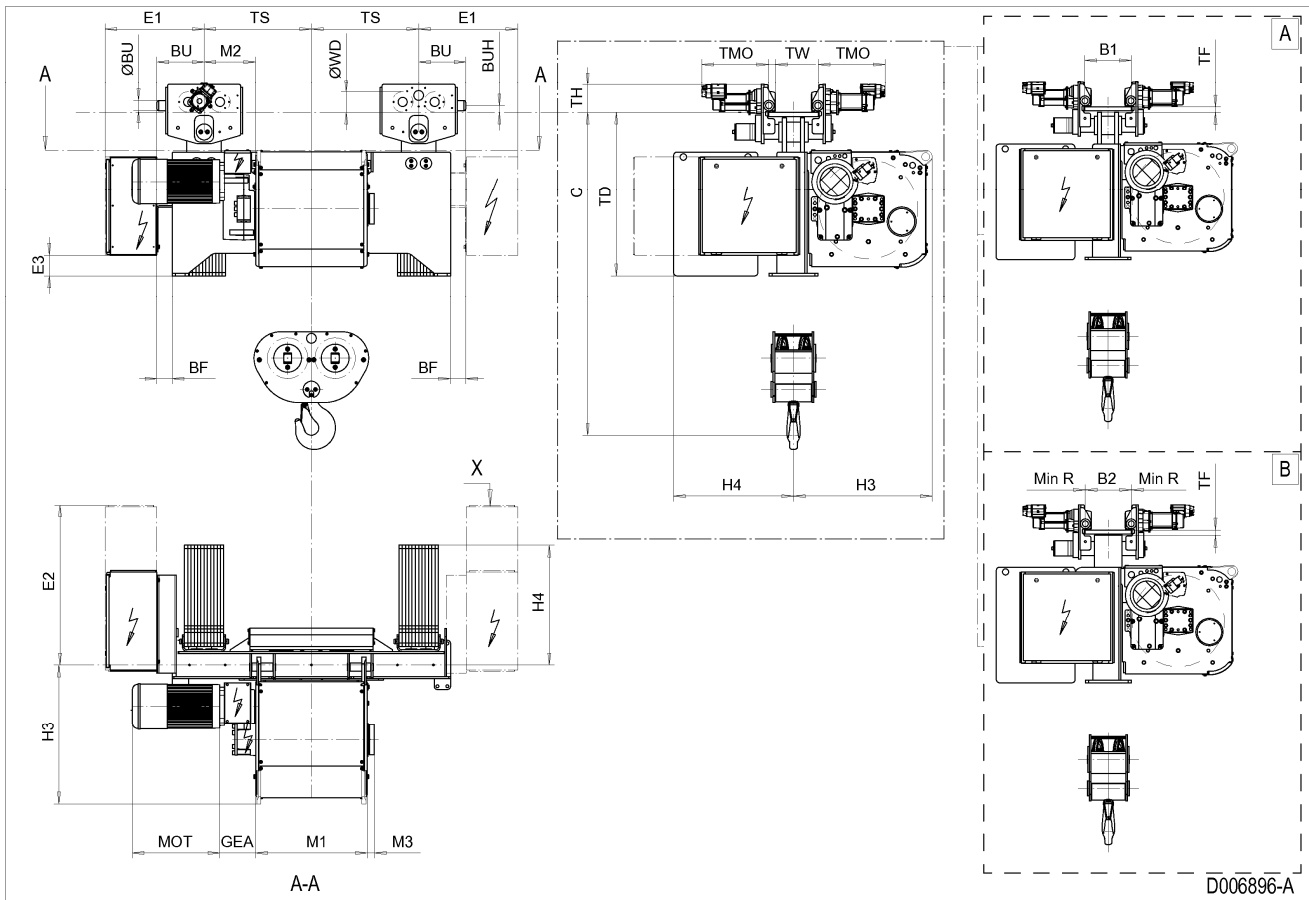

77 NORMAL HEADROOM HOIST NE, REEVING: 26

Hoist dimensions

HOL m	HOL* m	Length Code	E1 mm	M1 mm	M2 mm	TS mm	BF mm	Weight A** kg	Weight B** kg
5.5	3	E	605	682	314	655	170	2400	2600
7	4.5	F	605	832	239	655	170	2500	2700
9.5	7	G	605	1022	144	655	170	2700	2900
13	11.5	H	605	1272	319	955	170	2900	3200
17	14.5	J	605	1622	144	955	170	3200	3500
21	18.5	K	925	1922	-306	655	-150	3400	3700
25.5	23	L	925	2272	-481	655	-150	3700	4000
28.5	26	M	900	2522	-306	955	-125	4000	4400
32.5	30	N	900	2822	-456	955	-125	4200	4700

*HOL with drum brake

**Presence of a drum brake will increase weight by 80 kgs.

Motor dimensions

Motor	P6	P7	P8	A7	S7	S8	SA
MOT (mm)	536	576	711	536	715	763	803
Weight (kg)	85	105	106	71	81	97	120

Travelling dimensions

Motor	MF06LA
TMO (mm)	431
Weight (kg)	7.8

Trolley dimensions

B1 min	B1 max	B2 min	B2 max	C	ØBU	ØWD	Min R	BU	BUH	E2	E3
130	610	180	320	2086	80	180	4000	365	53	979	126
GEA	H3	H4	M3	TD	TF	TH	TW				
218	848	733	44	1008	45	208	53				

D006897_A

101304

Note: All dimensions in mm.

Note: Weight calculated with P6 motor when B=300 mm.

Note: Dimensions B1 min, B1 max and Weight A for normal track suspension.

Note: Dimensions B2 min, B2 max, Weight B and Min R for curved track suspension (option).

Normal Headroom Hoist NE, REEVING: 26

Electric panel size for hoists with Crane electric provisions

Trolley travel control type	2-speed --or-- MicroDrive	TravelMaster 3 power rating 002	TravelMaster 3 power ratings 003-004	TravelMaster 3 power ratings 005-007	TravelMaster 2p power ratings 002-005	TravelMaster 2p power ratings 007-011
Electric panel size + additional panel size Main voltage 400V or 460V	600x600	600x600	1000x600	600x600*	600x600 + 600x400	600x600*
Electric panel size + additional panel size Other main voltages	1000x600	1000x600	1000x600 + 600x400	600x600*	600x600*	600x600*

* Inverter in bridge panel.

Electric panel size for hoists with Solo electric provisions

Trolley travel control type	2-speed --or-- MicroDrive	TravelMaster 3 power rating 002	TravelMaster 3 power ratings 003-004	TravelMaster 3 power ratings 005-007	TravelMaster 2p power ratings 002-005	TravelMaster 2p power ratings 007-011
Electric panel size + additional panel size Main voltage 400V or 460V	1000x600	1000x600	1000x600	1000x600 + 1000x600	1000x600 + 600x400	1000x600 + 1000x600
Electric panel size + additional panel size Other main voltages	1000x600	1000x600	1000x600 + 600x400	1000x600 + 1000x600**	1000x600 + 600x400	1000x600 + 1000x600**

**Transformer in bridge panel.

Note: For hoists with Solo electric provisions and a hoisting inverter, a special cubicle layout is required. Please consult the factory.

Note: Detail view A for normal track suspension. Detail view B for curved track suspension (option).

Note: X points the location for an auxiliary electrical cubicle.

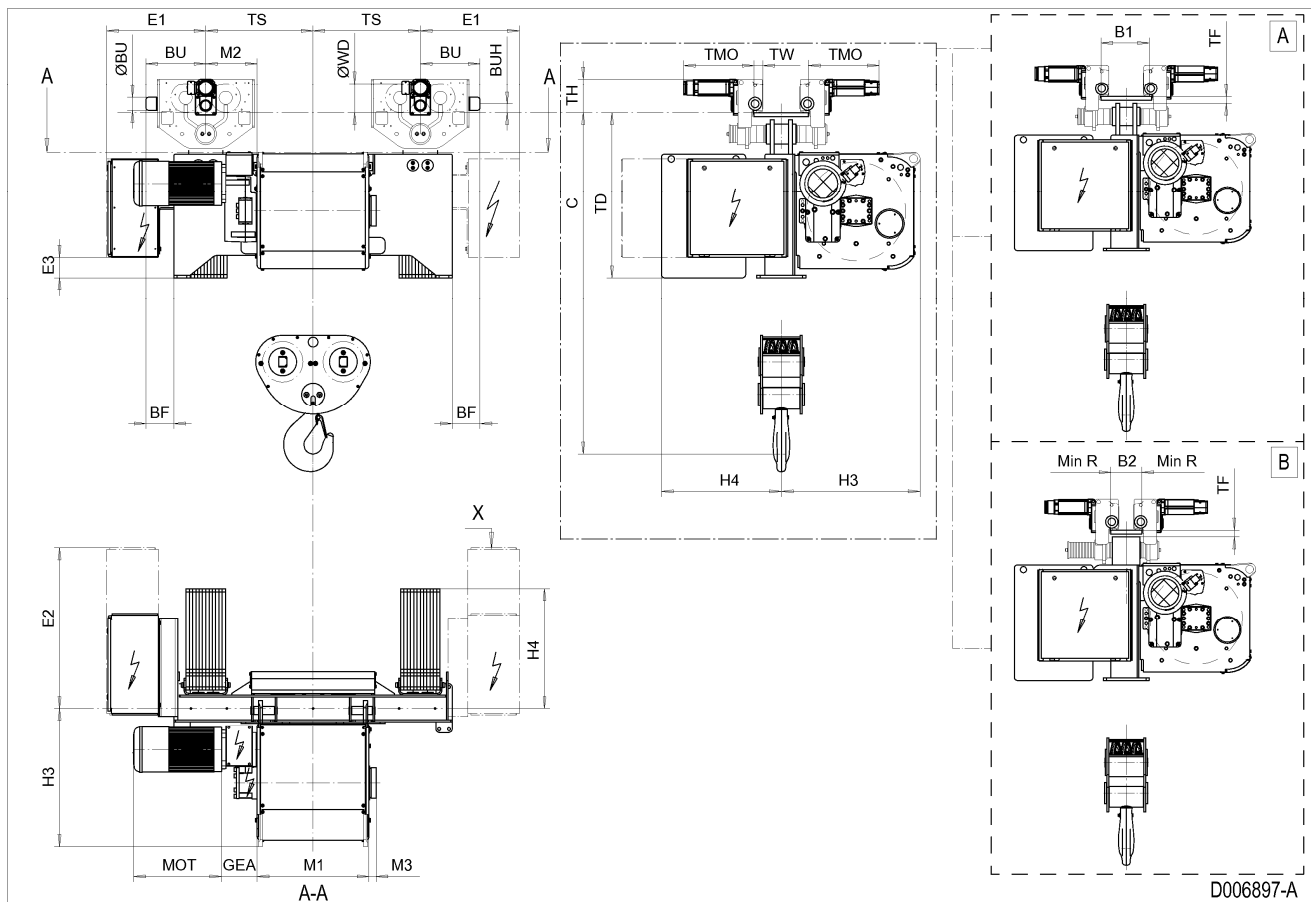

78 NORMAL HEADROOM HOIST NE, REEVING: 28

Hoist dimensions

HOL m	HOL* m	Length code	E1 mm	M1 mm	M2 mm	TS mm	BF mm	Weight A** kg	Weight B** kg
5.5	3.5	F	605	832	239	655	170	2700	2900
7	5	G	605	1022	144	655	170	2800	3000
9.5	7.5	H	605	1272	319	955	170	3000	3300
13	11	J	605	1622	144	955	170	3300	3600
15.5	13.5	K	925	1922	-306	655	-150	3500	3900
19	17	L	925	2272	-481	655	-150	3800	4200
21.5	19.5	M	900	2522	-306	955	-125	4100	4500
24.5	22.5	N	900	2822	-456	955	-125	4400	4800

*HOL with drum brake

**Presence of a drum brake will increase weight by 80 kgs.

Motor dimensions

Motor	P6	P7	P8	A7	S7	S8	SA
MOT (mm)	536	576	711	536	715	763	803
Weight (kg)	85	105	106	71	81	97	120

Travelling dimensions

Motor	MF06LA
TMO (mm)	431
Weight (kg)	7.8

Trolley dimensions

B1 min	B1 max	B2 min	B2 max	C	ØBU	ØWD	Min R	BU	BUH	E2	E3
130	610	180	320	2212	80	180	4000	365	53	979	126
GEA	H3	H4	M3	TD	TF	TH	TW				
218	848	733	44	1008	45	208	53				

D006898_A

101305

Note: All dimensions in mm.

Note: Weight calculated with P6 motor when B=300 mm.

Note: Dimensions B1 min, B1 max and Weight A for normal track suspension.

Note: Dimensions B2 min, B2 max, Weight B and Min R for curved track suspension (option).

Normal Headroom Hoist NE, REEVING: 28

Electric panel size for hoists with Crane electric provisions

Trolley travel control type	2-speed --or-- MicroDrive	TravelMaster 3 power rating 002	TravelMaster 3 power ratings 003-004	TravelMaster 3 power ratings 005-007	TravelMaster 2p power ratings 002-005	TravelMaster 2p power ratings 007-011
Electric panel size + additional panel size Main voltage 400V or 460V	600x600	600x600	1000x600	600x600*	600x600 + 600x400	600x600*
Electric panel size + additional panel size Other main voltages	1000x600	1000x600	1000x600 + 600x400	600x600*	600x600*	600x600*

* Inverter in bridge panel.

Electric panel size for hoists with Solo electric provisions

Trolley travel control type	2-speed --or-- MicroDrive	TravelMaster 3 power rating 002	TravelMaster 3 power ratings 003-004	TravelMaster 3 power ratings 005-007	TravelMaster 2p power ratings 002-005	TravelMaster 2p power ratings 007-011
Electric panel size + additional panel size Main voltage 400V or 460V	1000x600	1000x600	1000x600	1000x600 + 1000x600	1000x600 + 600x400	1000x600 + 1000x600
Electric panel size + additional panel size Other main voltages	1000x600	1000x600	1000x600 + 600x400	1000x600 + 1000x600**	1000x600 + 600x400	1000x600 + 1000x600**

**Transformer in bridge panel.

Note: For hoists with Solo electric provisions and a hoisting inverter, a special cubicle layout is required. Please consult the factory.

Note: Detail view A for normal track suspension. Detail view B for curved track suspension (option).

Note: X points the location for an auxiliary electrical cubicle.

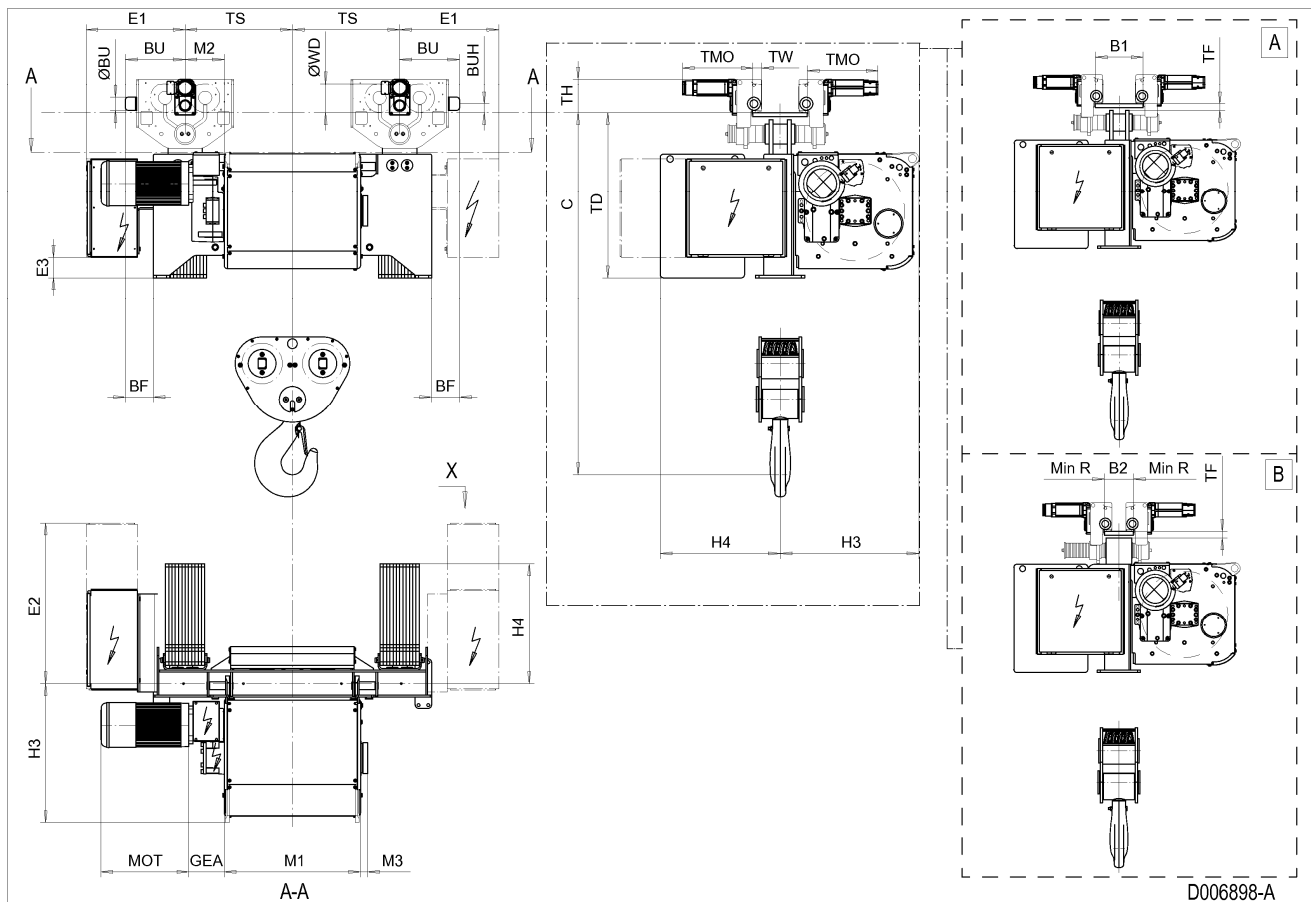

FIXED HOIST

79 FIXED HOIST NB, REEVING: 02

Hoist dimensions

HOL m	Length code	M1 mm	H2 mm	H3 mm	H3* mm	R mm	Weight kg
12	A	326	90	448	463	400	125
19	C	456	144	448	463	530	135

Motor dimensions

Motor	P1	P2	P3	A3	S3
MOT (mm)	386	446	476	446	526
Weight (kg)	21	31	35	32	28

Trolley dimensions

C	ØF	E3	F1	F3	GEA	H1	H4	M2	RO	TH	
195	18	78	100	100	110	127	391	37	25	395	

D002071_A
062131

Note: All dimensions in mm.

Note: Weight calculated with P1 motor.

* Please, disregard the dimension H3*.

Fixed Hoist NB, REEVING: 02

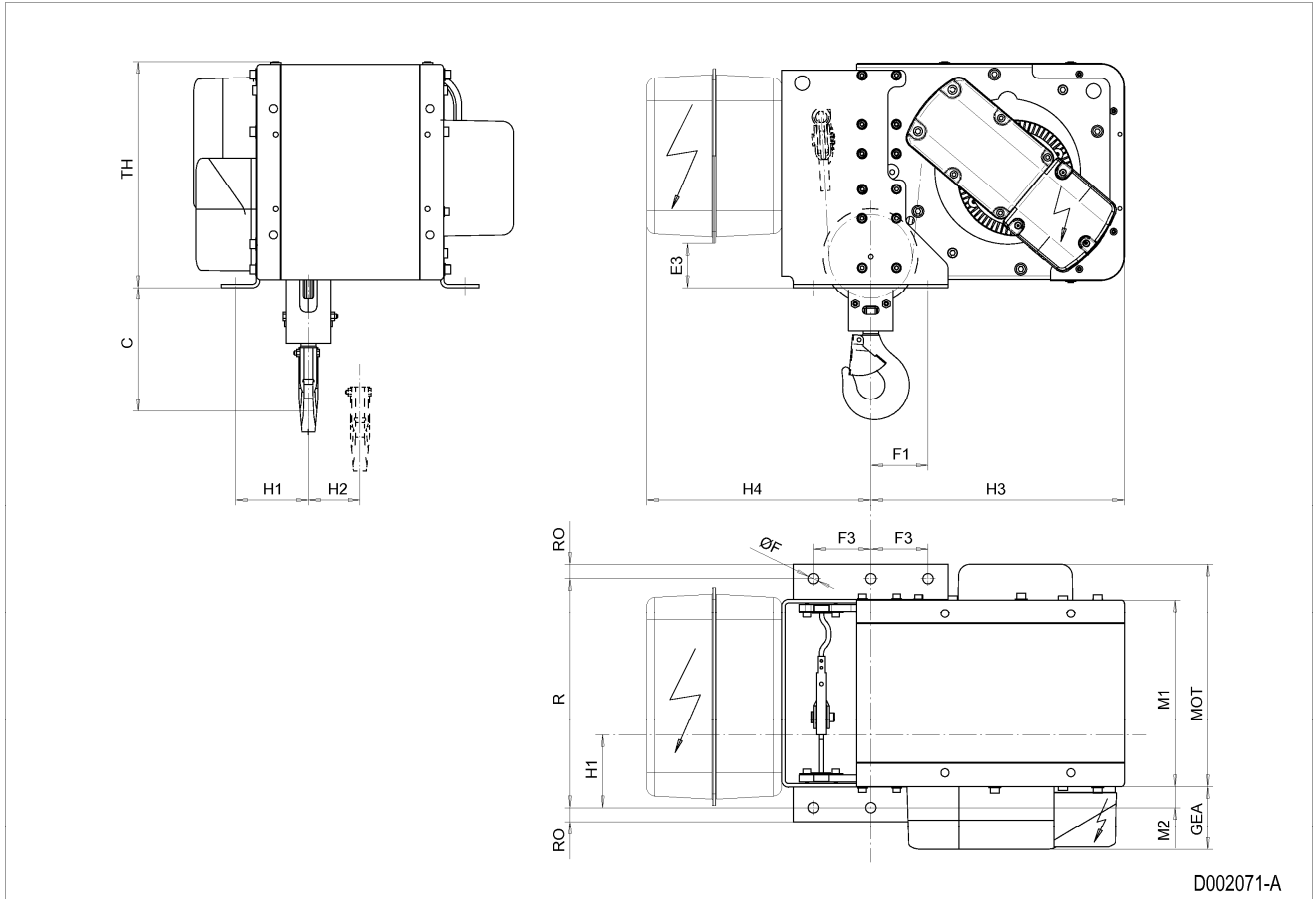

80 FIXED HOIST NB, REEVING: 04

Hoist dimensions

HOL m	Length code	M1 mm	H2 mm	H3 mm	H3* mm	R mm	Weight kg
6	A	326	45	461	476	400	130
9.5	C	456	72	461	476	530	140

Motor dimensions

Motor	P1	P2	P3	A3	S3
MOT (mm)	386	446	476	446	526
Weight (kg)	21	31	35	32	28

Trolley dimensions

C	ØF	E3	F1	F3	GEA	H1	H4	M2	RO	TH	
145	18	78	113	100	110	182	378	37	25	395	

D002078_A
062132

Note: All dimensions in mm.

Note: Weight calculated with P1 motor.

* Please, disregard the dimension H3*.

Fixed Hoist NB, REEVING: 04

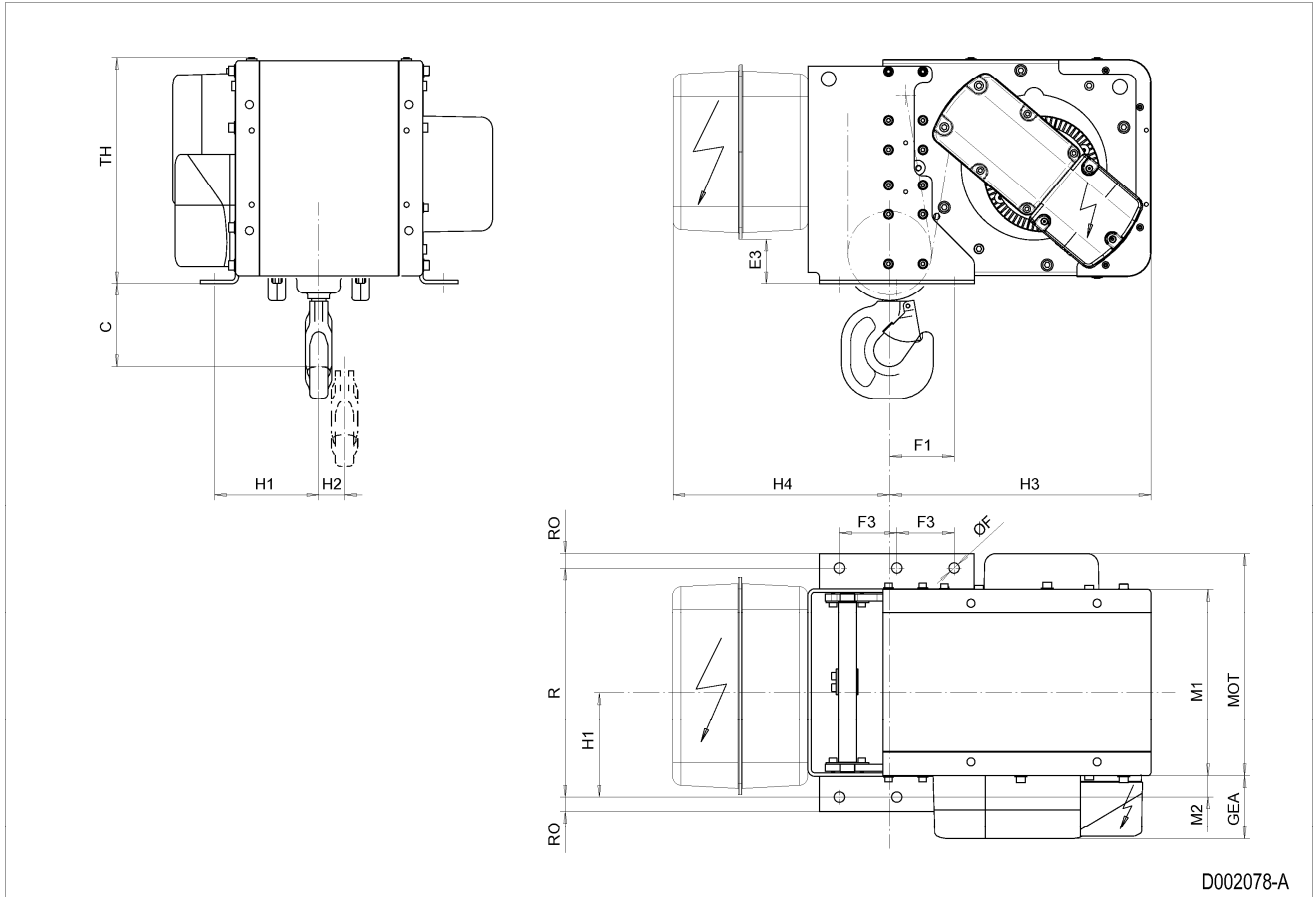

81 FIXED HOIST NC, REEVING: 02

Hoist dimensions

HOL m	Length code	M1 mm	M2 mm	H1 mm	H2 mm	H3 mm	H3* mm	R mm	Weight kg
12	B	356	153	239	98	528	544	560	195
18	C	456	53	139	147	528	544	560	205
24	D	556	53	139	196	528	544	780	220
30	E	676	53	139	256	528	544	780	240

Motor dimensions

Motor	P3	P4	A3	S3	S5
MOT (mm)	473	574	443	523	602
Weight (kg)	35	53	32	28	53

Trolley dimensions

C	ØF	E3	F1	F3	GEA	H4	RO	TH			
240	18	148	42	120	116	460	20	444			

D002086_A
062134

Note: All dimensions in mm.

Note: Weight calculated with P3 motor.

Note: Motor S5 is unavailable for load class 3200 kg.

* Please, disregard the dimension H3*.

Fixed Hoist NC, REEVING: 02

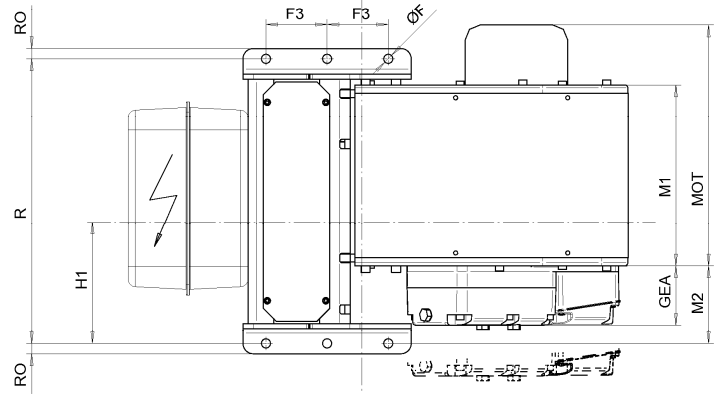
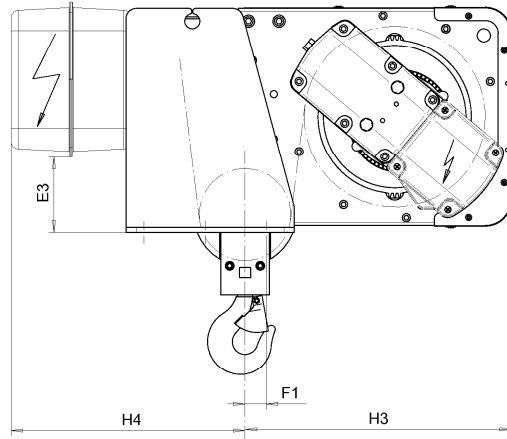
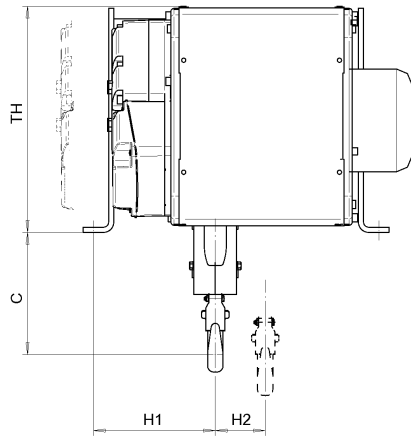

D002086-A

82 FIXED HOIST NC, REEVING: 04

Hoist dimensions

HOL m	Length code	M1 mm	M2 mm	H1 mm	H2 mm	H3 mm	H3* mm	R mm	Weight kg
6	B	356	153	320	49	551	567	560	200
9	C	456	53	220	73	551	567	560	210
12	D	556	53	220	97	551	567	780	220
15	E	676	53	220	127	551	567	780	230

Motor dimensions

Motor	P3	P4	A3	S3	S5
MOT (mm)	473	574	443	523	602
Weight (kg)	35	53	32	28	53

Trolley dimensions

C1	C2	ØF	E3	F1	F3	GEA	H4	RO	TH		
215	232	18	148	65	120	116	436	20	444		

D002091_A
062135

Note: All dimensions in mm.

Note: Weight calculated with P3 motor.

Note: Motor S5 is unavailable for load class 6300 kg.

* Please, disregard the dimension H3*.

Fixed Hoist NC, REEVING: 04

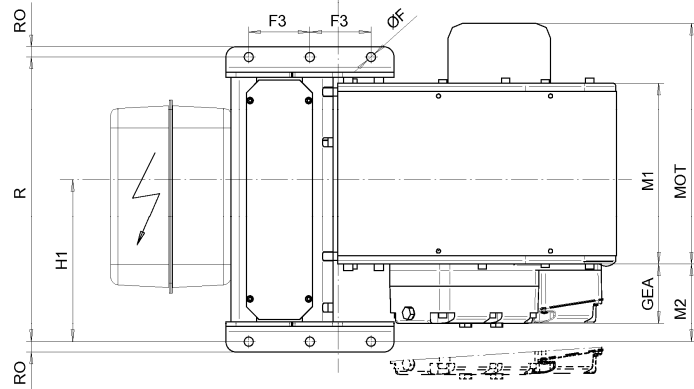
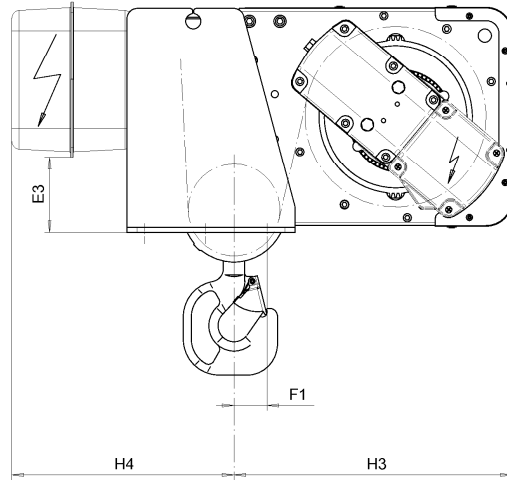
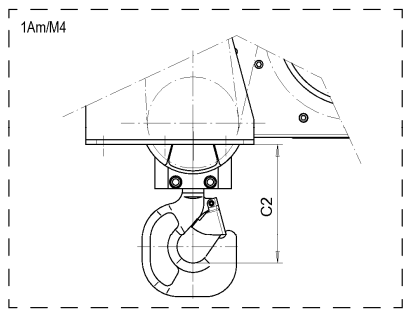
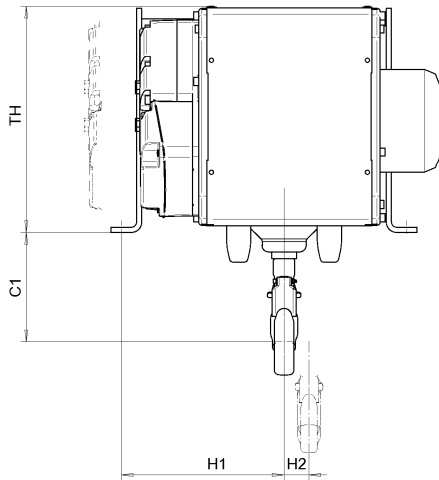

D002091-A

83 FIXED HOIST ND, REEVING: 02

Hoist dimensions

HOL m	Length code	M1 mm	M2 mm	H1 mm	H2 mm	H3 mm	H3* mm	R mm	Weight kg
18	D	558	196	354	176	621	641	830	430
24	E	678	76	234	235	621	641	830	445
32	F	828	76	234	310	621	641	1170	460
40	G	1018	76	234	405	621	641	1170	480

Motor dimensions

Motor	P5	P6	P7	A5	S5	S7
MOT (mm)	578	578	618	498	606	757
Weight (kg)	58	85	105	45	53	81

Trolley dimensions

C	ØF	E3	F1	F3	GEA	H4	RO	TH			
366	18	80	140	175	143	543	25	537			

D002111_A
062189

Note: All dimensions in mm.

Note: Weight calculated with P5 motor.

Note: Motor S7 is unavailable for load class 6300 kg.

* Please, disregard the dimension H3*.

Fixed Hoist ND, REEVING: 02

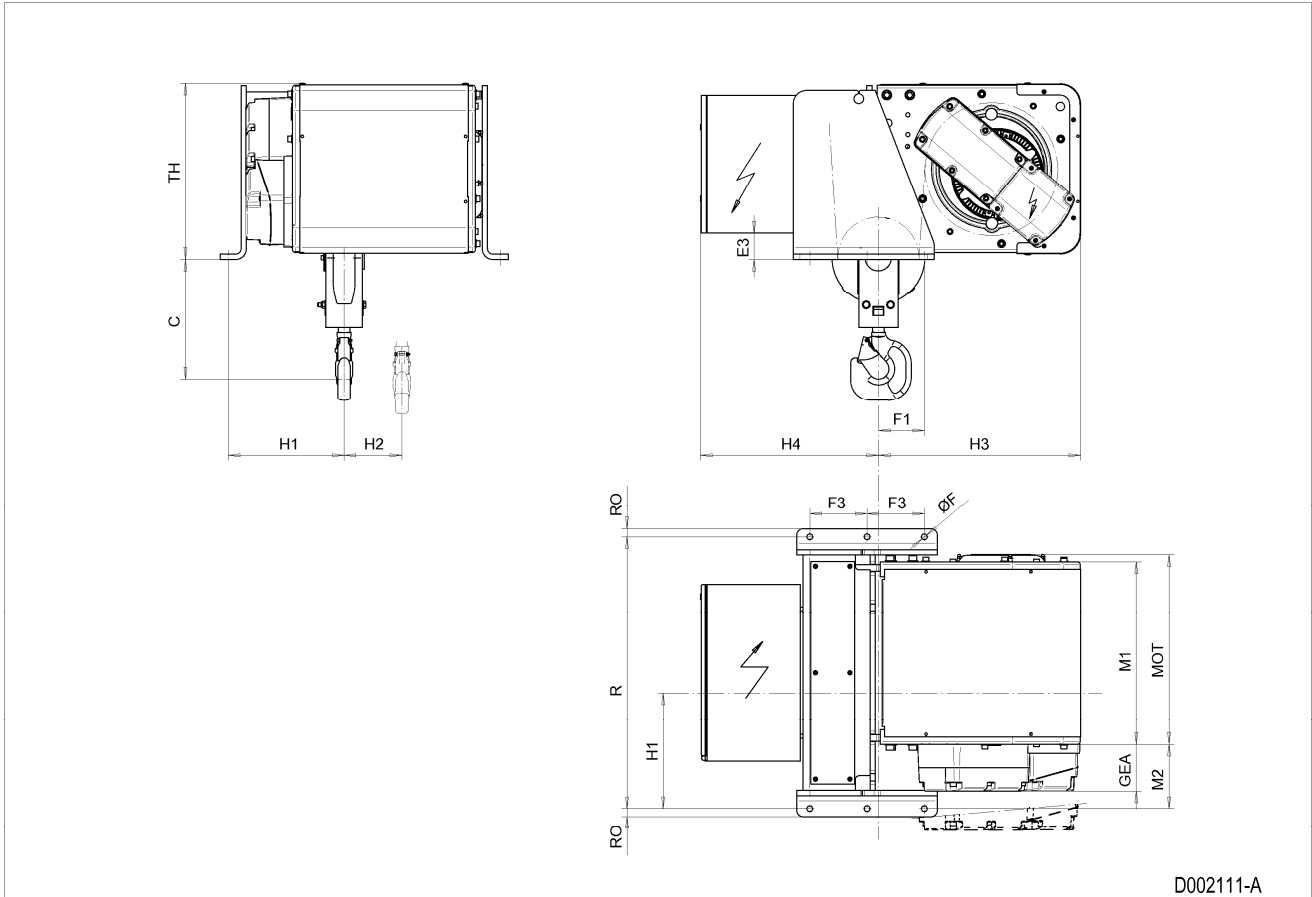

D002111-A

84 FIXED HOIST ND, REEVING: 04

Hoist dimensions

HOL m	Length code	M1 mm	M2 mm	H1 mm	H2 mm	H3 mm	H3* mm	R mm	Weight kg
9	D	558	196	434	88	645	665	830	445
12	E	678	76	314	118	645	665	830	460
16	F	828	76	314	156	645	665	1170	480
20	G	1018	76	314	204	645	665	1170	500

Motor dimensions

Motor	P5	P6	P7	A5	S5	S7
MOT (mm)	578	578	618	498	606	757
Weight (kg)	58	85	105	45	53	81

Trolley dimensions

C1	C2	ØF	E3	F1	F3	GEA	H4	RO	TH		
310	367	18	80	168	175	143	516	25	537		

D002116_A
062190

Note: All dimensions in mm.

Note: Weight calculated with P5 motor.

Note: Motor S7 is unavailable for load class 12500 kg.

* Please, disregard the dimension H3*.

Fixed Hoist ND, REEVING: 04

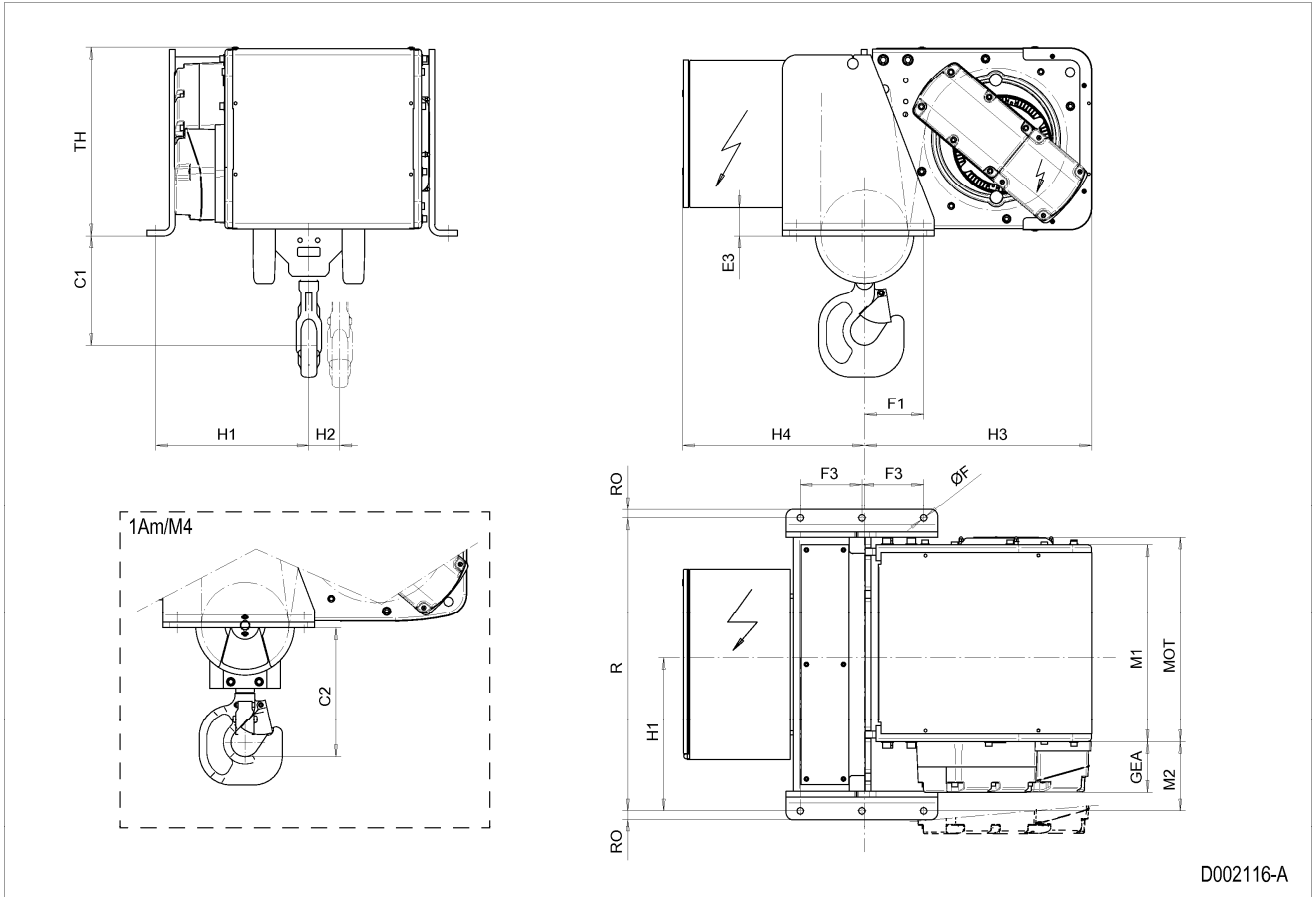

D002116-A

85 FIXED HOIST ND, REEVING: 06

Hoist dimensions

HOL m	Length code	M1 mm	M2 mm	Min R mm	H1 mm	H2 mm	H3 mm	H3* mm	Weight kg
6	D	558	548	1200	515	53	605	625	585
8	E	678	628	1400	595	78	605	625	625
10	F	828	778	1700	745	98	605	625	675
13	G	1018	888	2000	855	132	605	625	735

Motor dimensions

Motor	P5	P6	P7	A5	S5	S7
MOT (mm)	578	578	618	498	606	757
Weight (kg)	58	85	105	45	53	81

Trolley dimensions

C	ØF	E1	E3	E8	F1	F2	F3	GEA	H4	RO	TH
693	18	406	100	130	200	440	70	143	270	70	527

D007242_A
126313

Note: All dimensions in mm.

Note: Weight calculated with P5 motor.

Note: H1, M2 and weight calculated with Min R.

Note: Standard rail gauges: 1200, 1400, 1700, 2000 and 2400.

* Please, disregard the dimension H3*.

Fixed Hoist ND, REEVING: 06

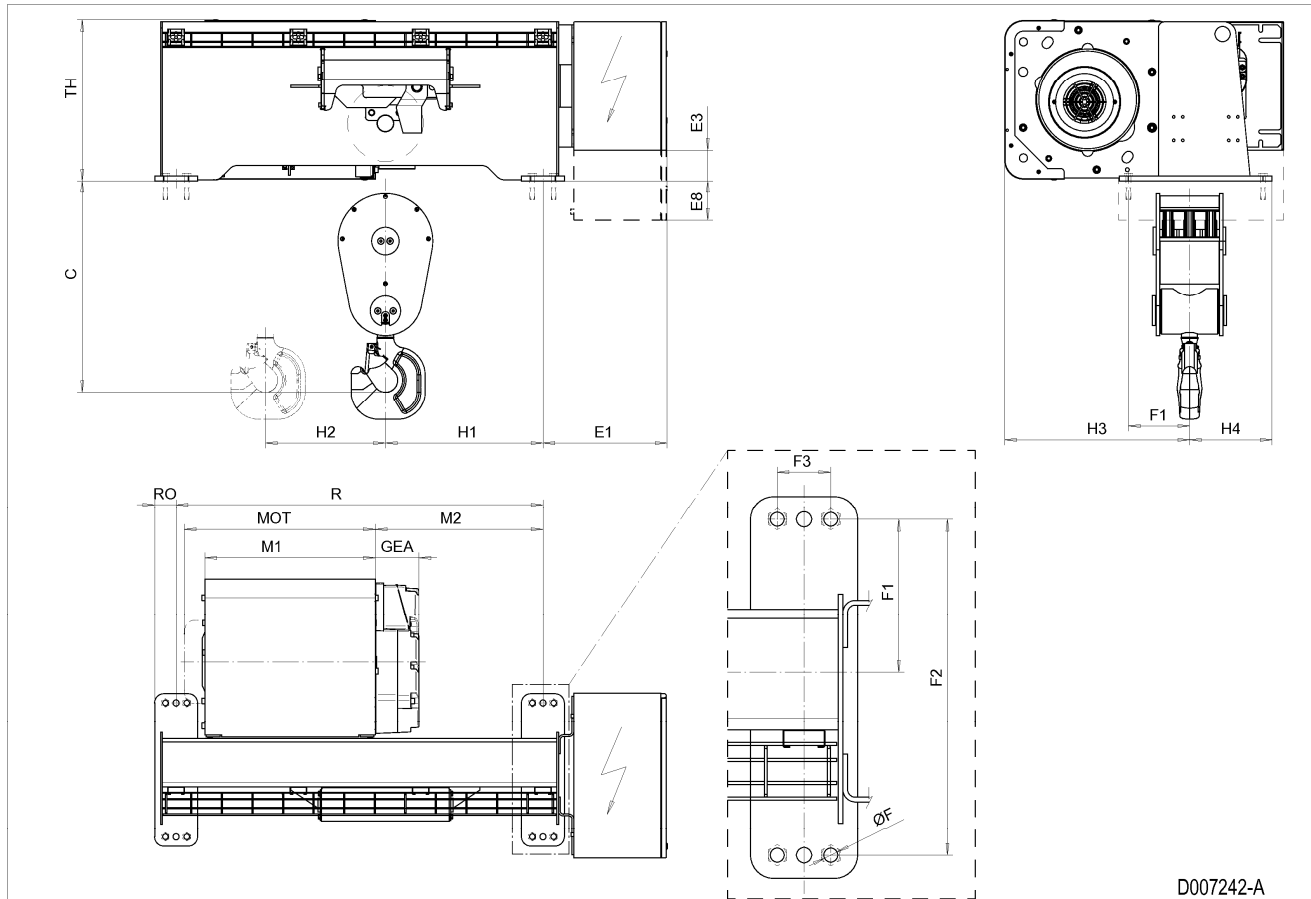

86 FIXED HOIST ND, REEVING: 08

Hoist dimensions

HOL m	Length code	M1 mm	M2 mm	Min R mm	H1 mm	H2 mm	H3 mm	H3* mm	Weight kg
4.5	D	558	548	1200	515	44	605	625	600
6	E	678	628	1400	595	53	605	625	635
8	F	828	778	1700	745	76	605	625	690
10	G	1018	888	2000	855	98	605	625	750

Motor dimensions

Motor	P5	P6	P7	A5	S5	S7
MOT (mm)	578	578	618	498	606	757
Weight (kg)	58	85	105	45	53	81

Trolley dimensions

C	ØF	E1	E3	E8	F1	F2	F3	GEA	H4	RO	TH
693	18	406	100	130	200	440	70	143	270	70	527

D007243_A
126314

Note: All dimensions in mm.

Note: Weight calculated with P5 motor.

Note: H1, M2 and weight calculated with Min R.

Note: Standard rail gauges: 1200, 1400, 1700, 2000 and 2400.

* Please, disregard the dimension H3*.

Fixed Hoist ND, REEVING: 08

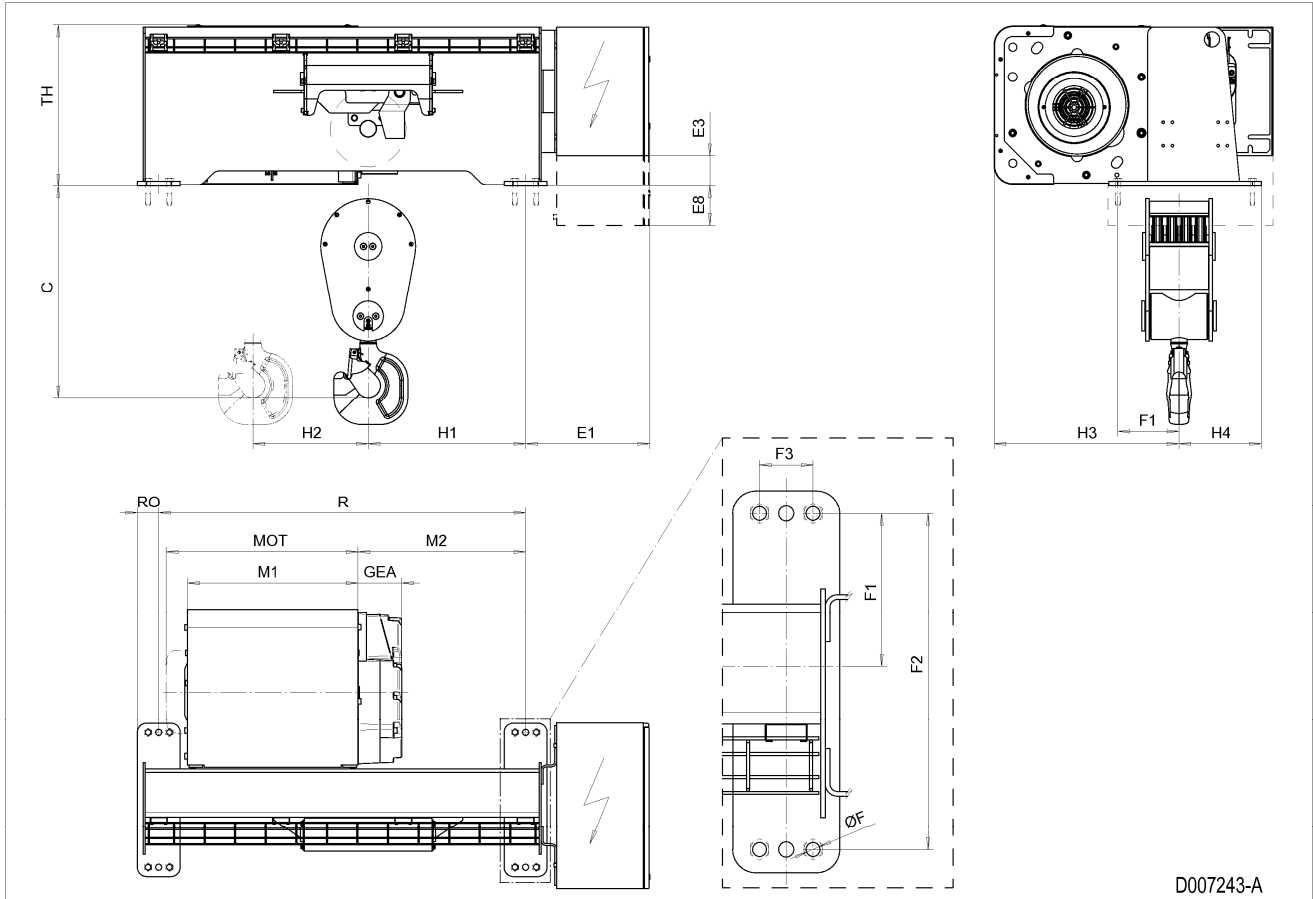

D007243-A

87 FIXED HOIST ND, REEVING: 22

Hoist dimensions

HOL m	Length code	M1 mm	M2 mm	Min R mm	BRA mm	H3 mm	H3* mm	Weight kg
8.5	D	558	321	1200	-	595	615	505
13	E	678	261	1200	-	595	615	530
18	F	828	186	1200	-	595	615	555
25	G	1018	91	1200	-	595	615	590
33.5	H	1268	216	1700	128	595	615	670
46	J	1618	191	2000	128	595	615	755

Motor dimensions

Motor	P5	P6	P7	A5	S5	S7
MOT (mm)	578	578	618	498	606	757
Weight (kg)	58	85	105	45	53	81

Trolley dimensions

C	ØF	E1	E3	E8	F1	F2	F3	GEA	H4	RO	TH
523	18	406	100	130	155	440	70	143	315	70	527

D007244_A
126316

Note: All dimensions in mm.

Note: Weight calculated with P5 motor.

Note: M2 and weight calculated with Min R.

Note: Standard rail gauges: 1200, 1700 and 2000.

Note: Gear brake as standard brake for drum lengths H and J.

* Please, disregard the dimension H3*.

Fixed Hoist ND, REEVING: 22

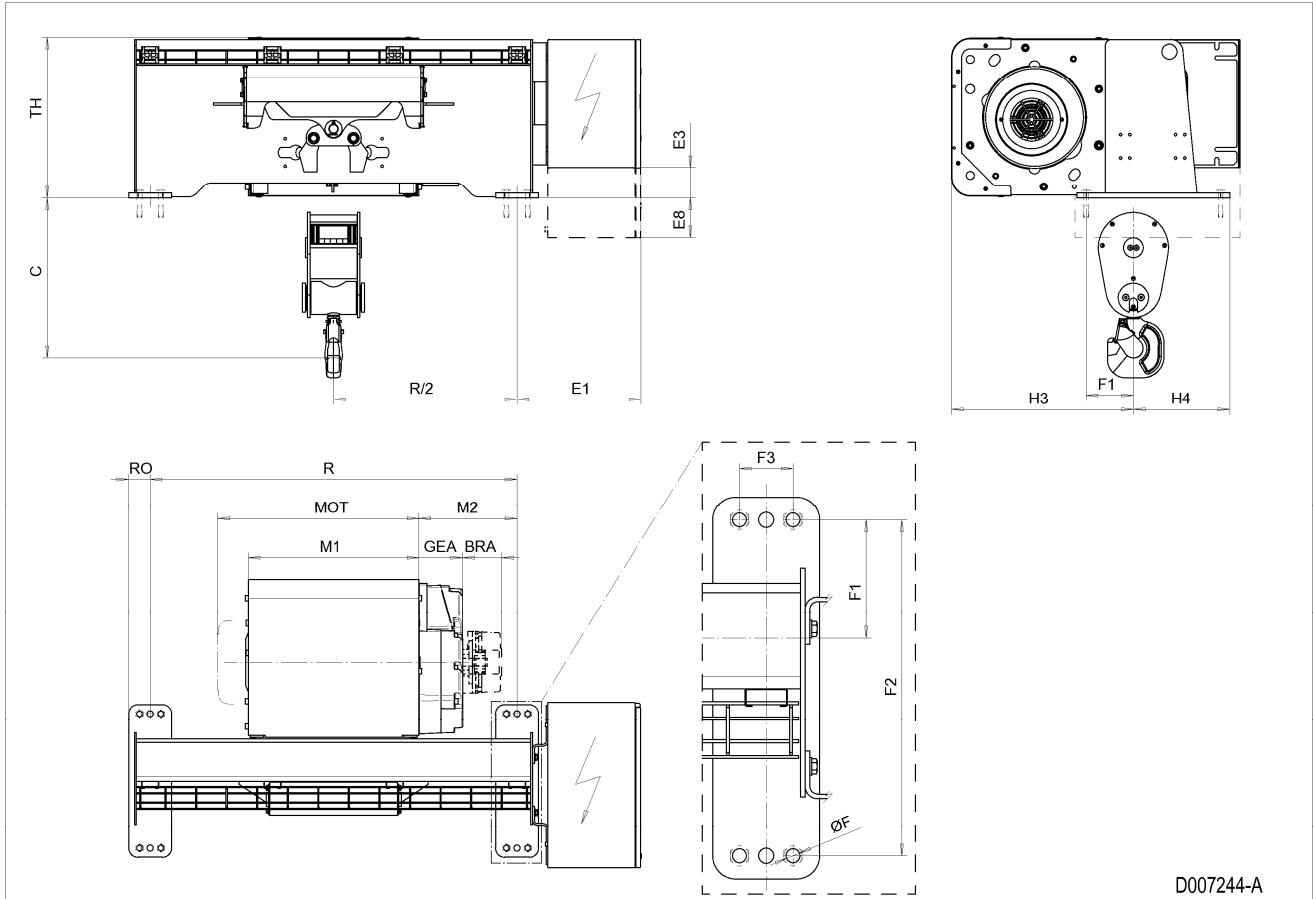

88 FIXED HOIST ND, REEVING: 24

Hoist dimensions

HOL m	Length code	M1 mm	M2 mm	Min R mm	BRA mm	H3 mm	H3* mm	Weight kg
4	D	558	321	1200	-	595	615	570
6.5	E	678	261	1200	-	595	615	590
9	F	828	186	1200	-	595	615	620
12.5	G	1018	91	1200	-	595	615	655
16.5	H	1268	216	1700	128	595	615	735
23	J	1618	191	2000	128	595	615	815

Motor dimensions

Motor	P5	P6	P7	A5	S5	S7
MOT (mm)	578	578	618	498	606	757
Weight (kg)	58	85	105	45	53	81

Trolley dimensions

C	ØF	E1	E3	E8	F1	F2	F3	GEA	H4	RO	TH
688	18	406	100	130	155	440	70	143	315	70	527

D007245_A
126317

Note: All dimensions in mm.

Note: Weight calculated with P5 motor.

Note: M2 and weight calculated with Min R.

Note: Standard rail gauges: 1200, 1700 and 2000.

Note: Gear brake as standard brake for drum lengths H and J.

* Please, disregard the dimension H3*.

Fixed Hoist ND, REEVING: 24

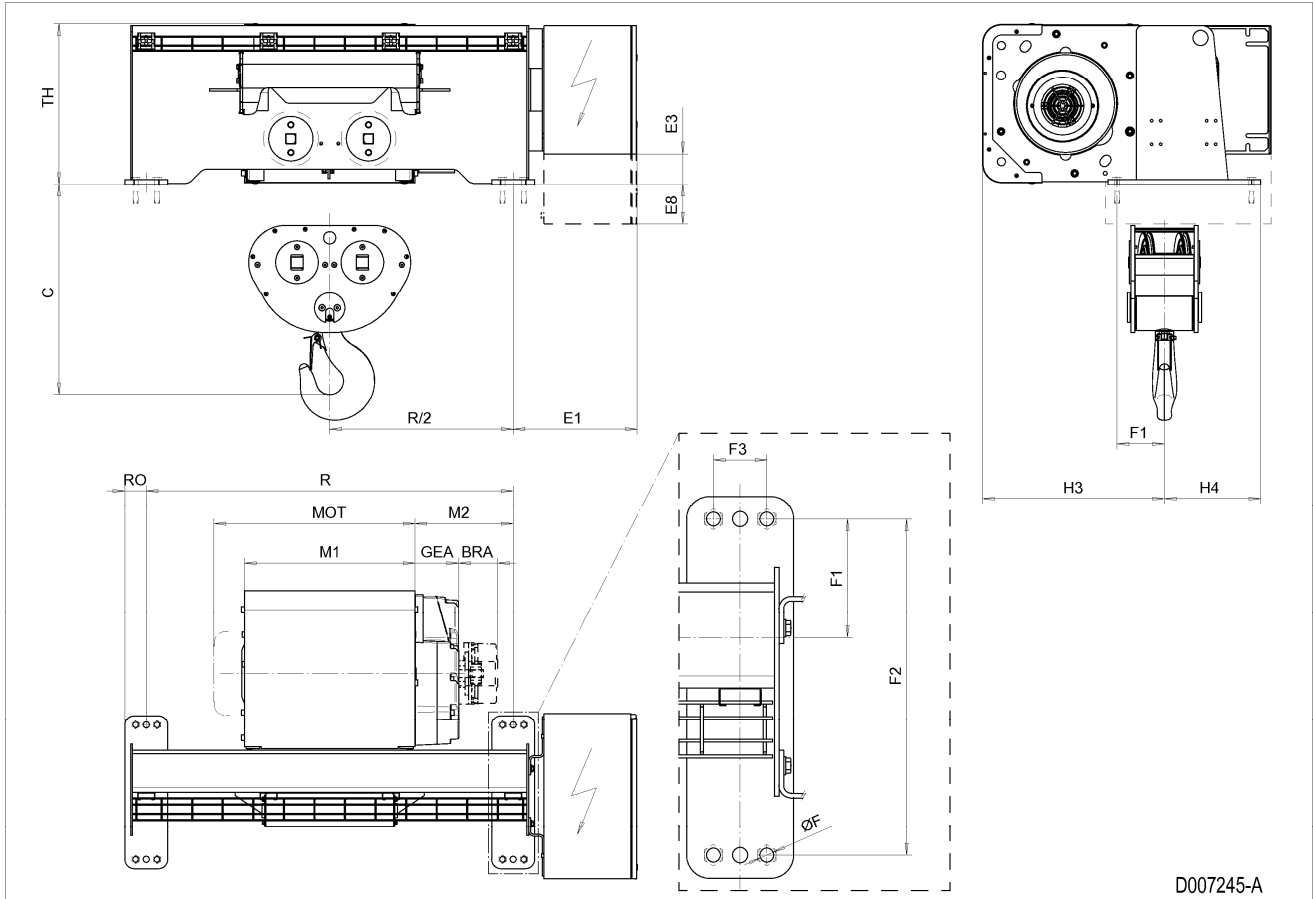

89 FIXED HOIST ND, REEVING: 26

Hoist dimensions

HOL m	Length code	M1 mm	M2 mm	Min R mm	BRA mm	H3 mm	H3* mm	Weight kg
4	E	678	261	1200	-	595	615	600
6	F	828	186	1200	-	595	615	625
8	G	1018	91	1200	-	595	615	665
11	H	1268	216	1700	128	595	615	745
15	J	1618	191	2000	128	595	615	830

Motor dimensions

Motor	P5	P6	P7	A5	S5	S7
MOT (mm)	578	578	618	498	606	757
Weight (kg)	58	85	105	45	53	81

Trolley dimensions

C	ØF	E1	E3	E8	F1	F2	F3	GEA	H4	RO	TH
688	18	406	100	130	200	440	70	143	270	70	527

D007246_A
126318

Note: All dimensions in mm.

Note: Weight calculated with P5 motor.

Note: M2 and weight calculated with Min R.

Note: Standard rail gauges: 1200, 1700 and 2000.

Note: Gear brake as standard brake for drum lengths H and J.

* Please, disregard the dimension H3*.

Fixed Hoist ND, REEVING: 26

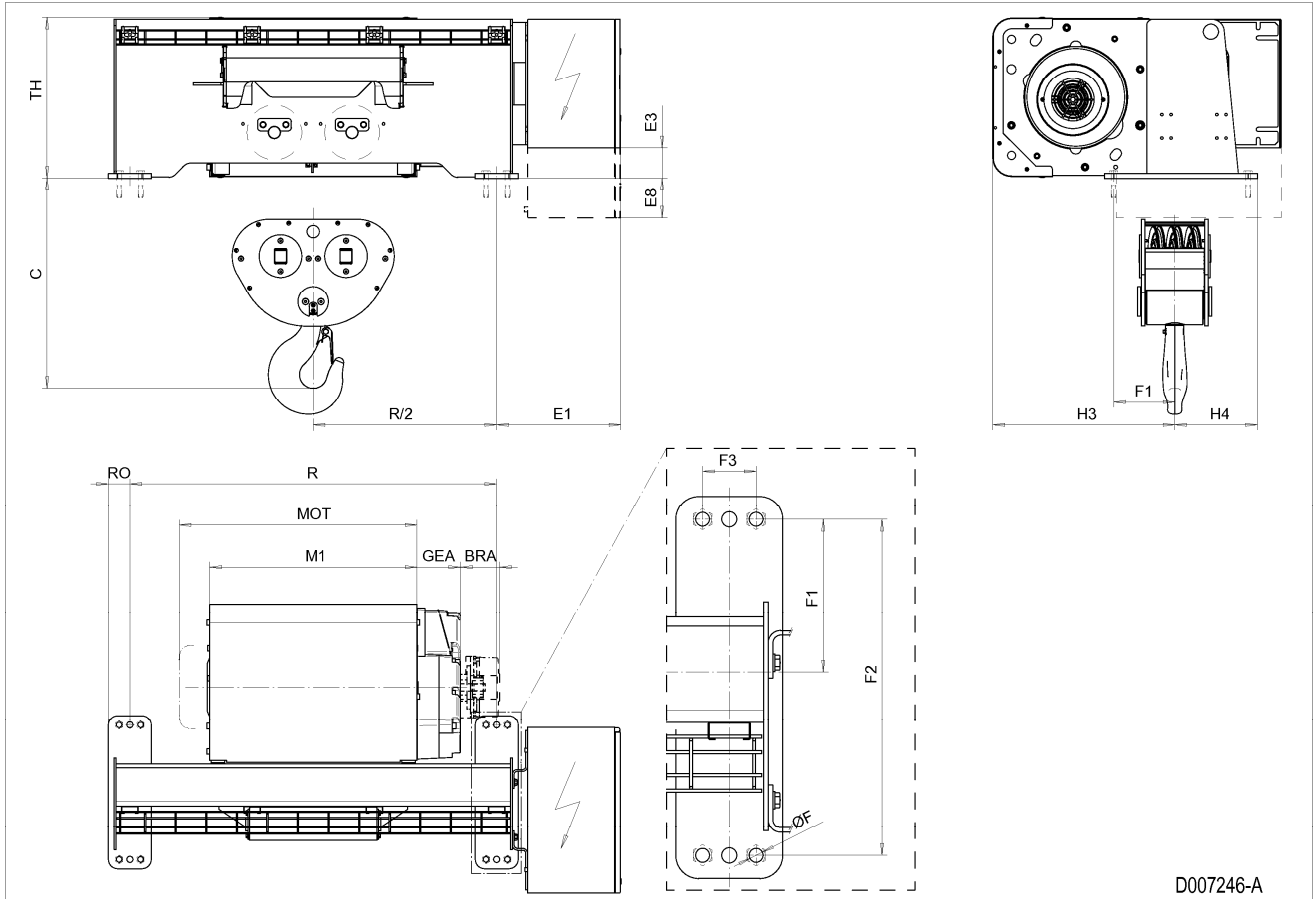

90 FIXED HOIST ND, REEVING: 28

Hoist dimensions

HOL m	Length code	M1 mm	M2 mm	Min R mm	BRA mm	H3 mm	H3* mm	Weight kg
4.5	F	828	186	1200	-	595	615	640
6	G	1018	91	1200	-	595	615	675
8	H	1268	216	1700	128	595	615	755
11.5	J	1618	191	2000	128	595	615	815

Motor dimensions

Motor	P5	P6	P7	A5	S5	S7
MOT (mm)	578	578	618	498	606	757
Weight (kg)	58	85	105	45	53	81

Trolley dimensions

C	ØF	E1	E3	E8	F1	F2	F3	GEA	H4	RO	TH
688	18	406	100	130	200	440	70	143	270	70	527

D007247_A
126319

Note: All dimensions in mm.

Note: Weight calculated with P5 motor.

Note: M2 and weight calculated with Min R.

Note: Standard rail gauges: 1200, 1700 and 2000.

Note: Gear brake as standard brake for drum lengths H and J.

* Please, disregard the dimension H3*.

Fixed Hoist ND, REEVING: 28

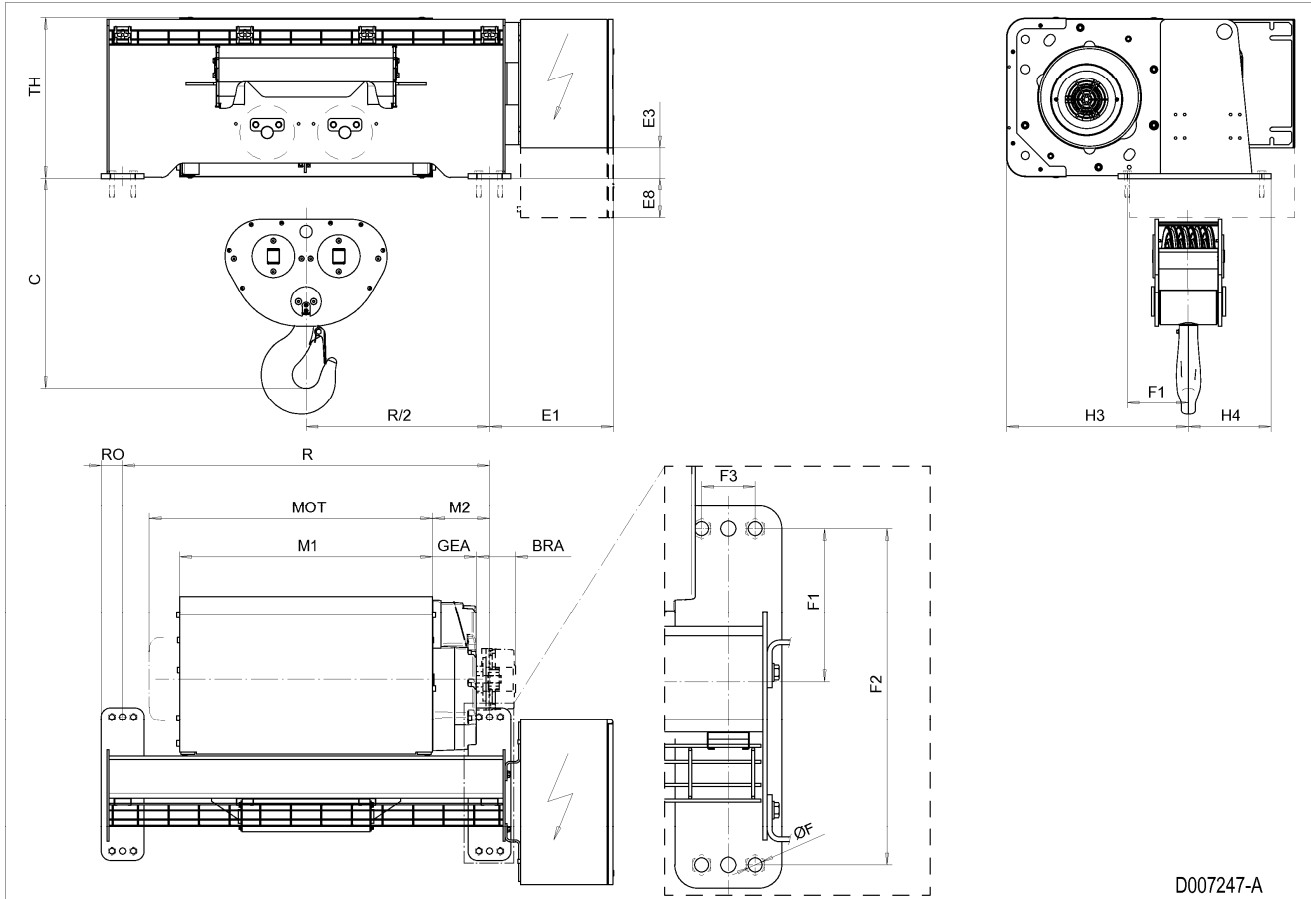

D007247-A

91 FIXED HOIST NE, REEVING: 02

Hoist dimensions

HOL m	HOL* m	Length code	R mm	M1 mm	M2 mm	H1 mm	H2 mm	Weight** kg
15.5	10	C	1610	462	760	700	139	1200
21	15.5	D	1610	562	760	700	188	1300
28	22.5	E	1840	682	590	650	251	1300
36	30.5	F	1840	832	590	650	322	1400
47	41.5	G	2350	1022	670	730	421	1500
61	55.5	H	2350	1272	670	730	546	1600
80.5	75	J	2759	1622	840	690	721	1900
97	91.5	K	2759	1922	840	690	868	2000

*HOL with drum brake

**Presence of a drum brake will increase weight by 80 kgs.

Motor dimensions

Motor	P6	P7	P8	A7	S7	S8	SA
MOT (mm)	536	576	711	536	715	763	803
Weight (kg)	85	105	106	71	81	97	120

Trolley dimensions

C	ØF	E1	E2	E3	F1	F2	F3	GEA	H3	M3	RO
754	18	455	960	126	158.5	320	60	218	871	44	50
TH											
769											

D006936_A
102573

Note: All dimensions in mm.

Note: Weight calculated with P6 motor.

Note: X points the location for an auxiliary electrical cubicle.

Fixed Hoist NE, REEVING: 02

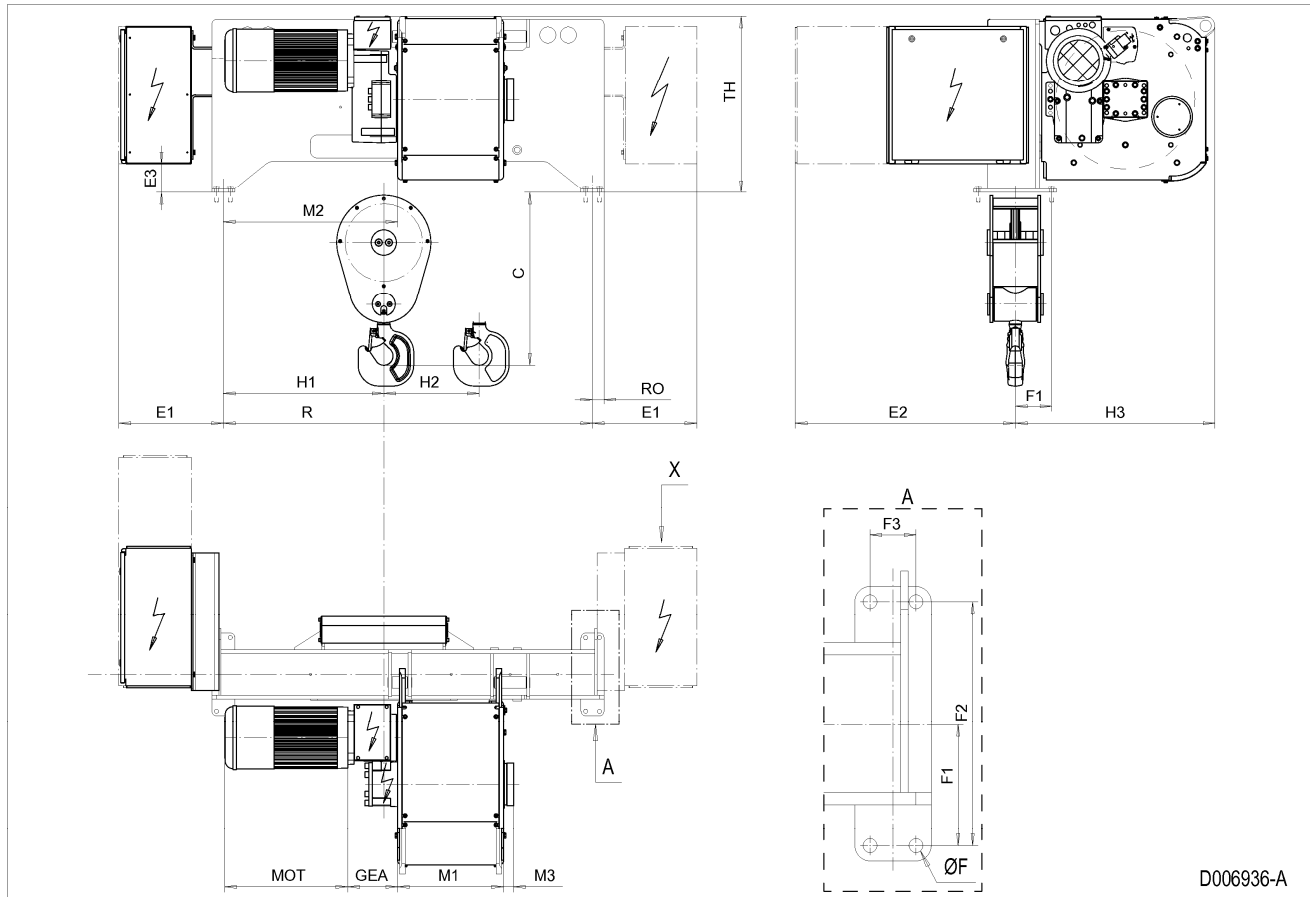

92 FIXED HOIST NE, REEVING: 04

Hoist dimensions

HOL m	HOL* m	Length code	R mm	M1 mm	M2 mm	H1 mm	H2 mm	Weight** kg
7.5	4.5	C	1610	462	760	700	69	1300
10.5	7.5	D	1610	562	760	700	94	1300
14	11	E	1840	682	590	650	125	1400
18	15	F	1840	832	590	650	161	1400
23.5	20.5	G	2350	1022	670	730	210	1600
30.5	27.5	H	2350	1272	670	730	273	1700
40	37	J	2759	1622	840	690	360	1900
48.5	45.5	K	2759	1922	840	690	434	2100

*HOL with drum brake

**Presence of a drum brake will increase weight by 80 kgs.

Motor dimensions

Motor	P6	P7	P8	A7	S7	S8	SA
MOT (mm)	536	576	711	536	715	763	803
Weight (kg)	85	105	106	71	81	97	120

Trolley dimensions

C	ØF	E1	E2	E3	F1	F2	F3	GEA	H3	M3	RO
754	18	455	960	126	158.5	320	60	218	871	44	50
TH											
769											

D006937_A
102574

Note: All dimensions in mm.

Note: Weight calculated with P6 motor.

Note: X points the location for an auxiliary electrical cubicle.

Fixed Hoist NE, REEVING: 04

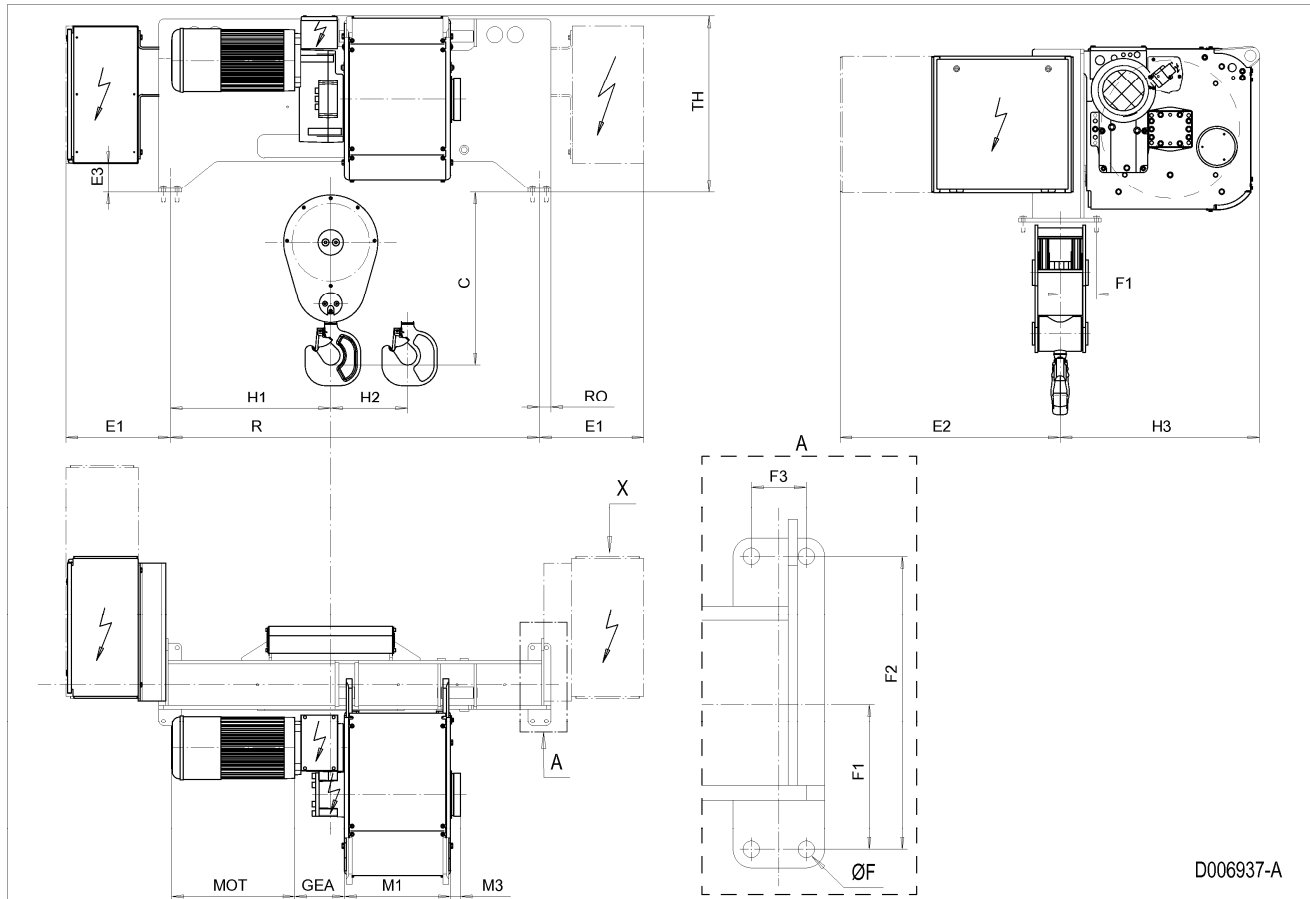

D006937-A

93 FIXED HOIST NE, REEVING: 06

Hoist dimensions

HOL m	HOL* m	Length code	R mm	M1 mm	M2 mm	H1 mm	H2 mm	Weight** kg
5	3	C	1610	462	760	700	46	1300
7	5	D	1610	562	760	700	63	1400
9	7	E	1840	682	590	650	84	1500
12	10	F	1840	832	590	650	107	1500
15.5	13.5	G	2350	1022	670	730	140	1600
20	18	H	2350	1272	670	730	182	1800
26.5	24.5	J	2759	1622	840	690	240	2000
32	30	K	2759	1922	840	690	289	2100

*HOL with drum brake

**Presence of a drum brake will increase weight by 80 kgs.

Motor dimensions

Motor	P6	P7	P8	A7	S7	S8	SA
MOT (mm)	536	576	711	536	715	763	803
Weight (kg)	85	105	106	71	81	97	120

Trolley dimensions

C	ØF	E1	E2	E3	F1	F2	F3	GEA	H3	M3	RO
873	18	455	960	126	158.5	320	60	218	871	44	50
TH											
769											

D006938_A
102575

Note: All dimensions in mm.

Note: Weight calculated with P6 motor.

Note: X points the location for an auxiliary electrical cubicle.

Fixed Hoist NE, REEVING: 06

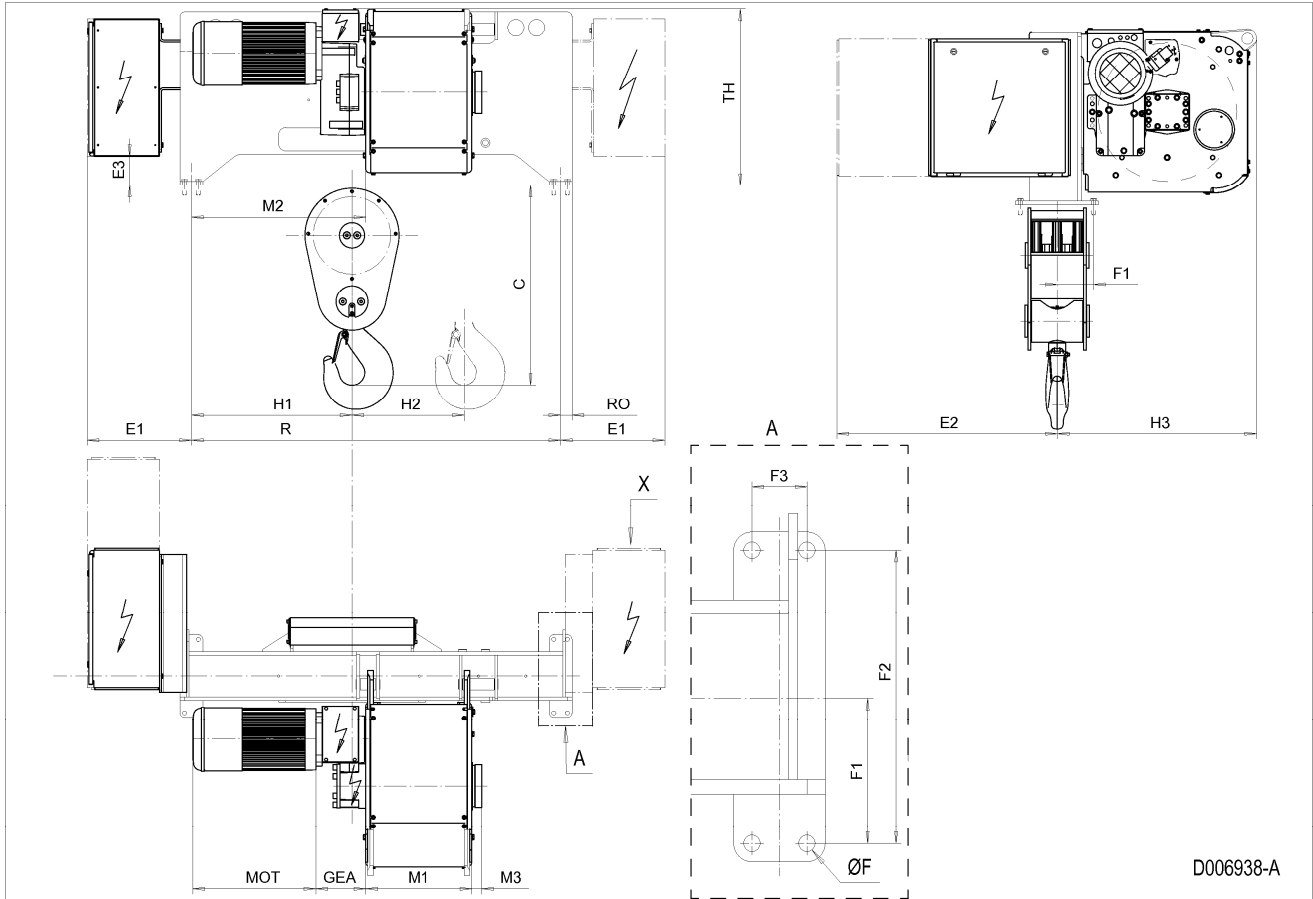

94 FIXED HOIST NE, REEVING: 08

Hoist dimensions

HOL m	HOL* m	Length code	R mm	M1 mm	M2 mm	H1 mm	H2 mm	Weight** kg
7	5.5	E	1840	682	590	650	63	1500
9	7.5	F	1840	832	590	650	81	1600
11.5	10	G	2350	1022	670	730	105	1700
15	13.5	H	2350	1272	670	730	137	1800
20	18.5	J	2759	1622	840	690	180	2100
24	22.5	K	2759	1922	840	690	217	2200

*HOL with drum brake

**Presence of a drum brake will increase weight by 80 kgs.

Motor dimensions

Motor	P6	P7	P8	A7	S7	S8	SA
MOT (mm)	536	576	711	536	715	763	803
Weight (kg)	85	105	106	71	81	97	120

Trolley dimensions

C	ØF	E1	E2	E3	F1	F2	F3	GEA	H3	M3	RO
1096	18	455	960	126	158.5	320	60	218	871	44	50
TH											
769											

D006939_A
102576

Note: All dimensions in mm.

Note: Weight calculated with P6 motor.

Note: X points the location for an auxiliary electrical cubicle.

Fixed Hoist NE, REEVING: 08

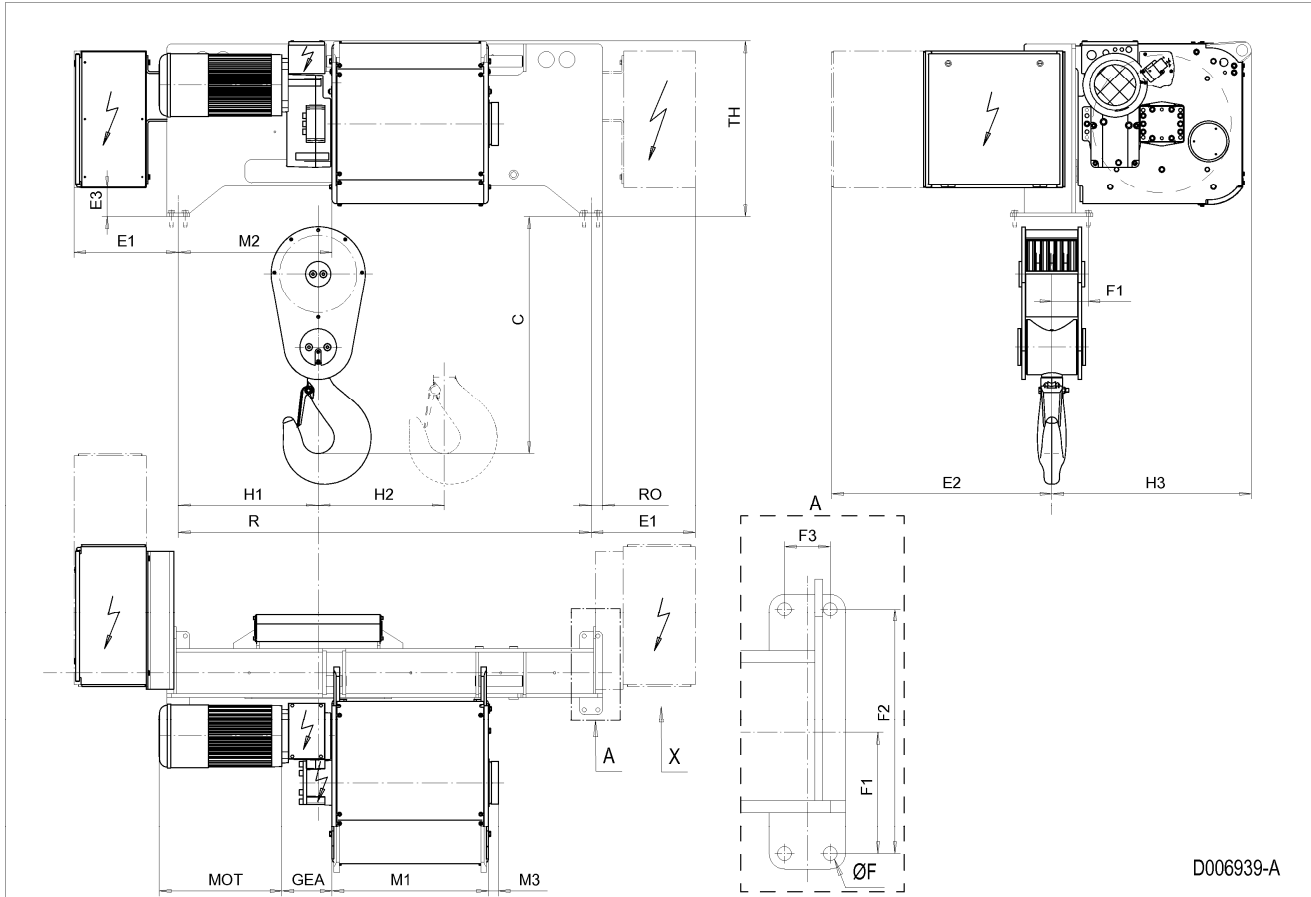

95 FIXED HOIST NE, REEVING: 22

Hoist dimensions

HOL m	HOL* m	Length code	R mm	M1 mm	M2 mm	Weight** kg
16.5	9	E	1600	682	459	1200
22	14.5	F	1600	832	384	1300
29.5	22	G	1600	1022	289	1300
39	31.5	H	2200	1272	464	1500
52	44.5	J	2200	1622	289	1600
63.5	56	K	2240	1922	164	1800
77	69.5	L	2240	2272	-10	2000
86.5	79	M	2790	2522	139	2200
98	90.5	N	2790	2822	-10	2300

*HOL with drum brake

**Presence of a drum brake will increase weight by 80 kgs.

Motor dimensions

Motor	P6	P7	P8	A7	S7	S8	SA
MOT (mm)	536	576	711	536	715	763	803
Weight (kg)	85	105	106	71	81	97	120

Trolley dimensions

C	ØF	E1	E2	E3	F1	F2	F3	GEA	H3	M3	RO
731	18	460	979	126	129.5	260	60	218	847	44	50
TH											
769											

D006940_A
102577

Note: All dimensions in mm.

Note: Weight calculated with P6 motor.

Note: X points the location for an auxiliary electrical cubicle.

Fixed Hoist NE, REEVING: 22

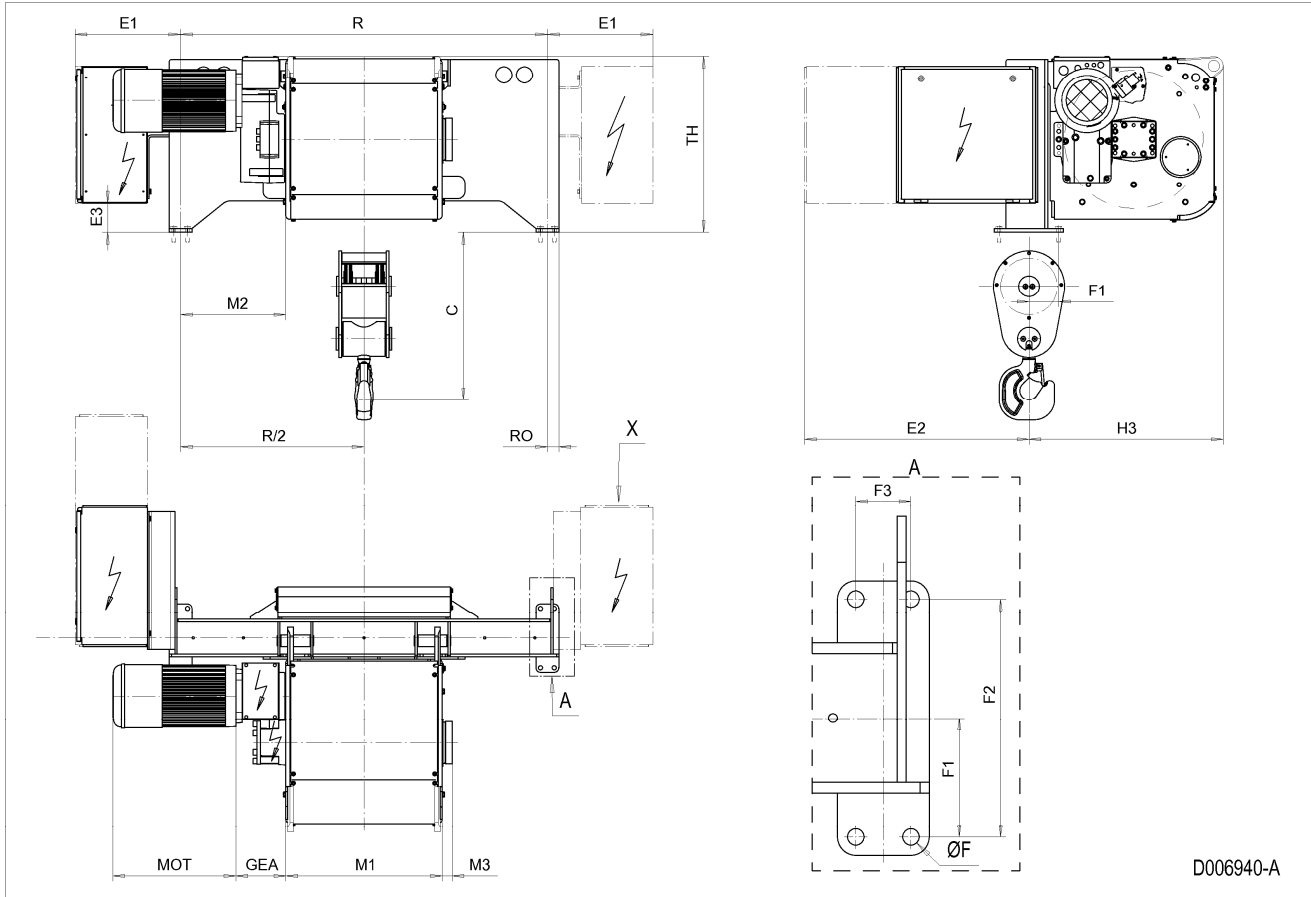

96 FIXED HOIST NE, REEVING: 24

Hoist dimensions

HOL m	HOL* m	Length code	R mm	M1 mm	M2 mm	Weight** kg
8	4	E	1600	682	459	1300
11	7	F	1600	832	384	1300
14.5	10.5	G	1600	1022	289	1400
19.5	15.5	H	2200	1272	464	1600
26	22	J	2200	1622	289	1700
31.5	27.5	K	2240	1922	164	1900
38.5	34.5	L	2240	2272	-10	2000
43	39	M	2790	2522	139	2200
49	45	N	2790	2822	-10	2400

*HOL with drum brake

**Presence of a drum brake will increase weight by 80 kgs.

Motor dimensions

Motor	P6	P7	P8	A7	S7	S8	SA
MOT (mm)	536	576	711	536	715	763	803
Weight (kg)	85	105	106	71	81	97	120

Trolley dimensions

C	ØF	E1	E2	E3	F1	F2	F3	GEA	H3	M3	RO
1040	18	460	979	126	129.5	260	60	218	847	44	50
TH											
769											

D006941_A

102578

Note: All dimensions in mm.

Note: Weight calculated with P6 motor.

Note: X points the location for an auxiliary electrical cubicle.

Fixed Hoist NE, REEVING: 24

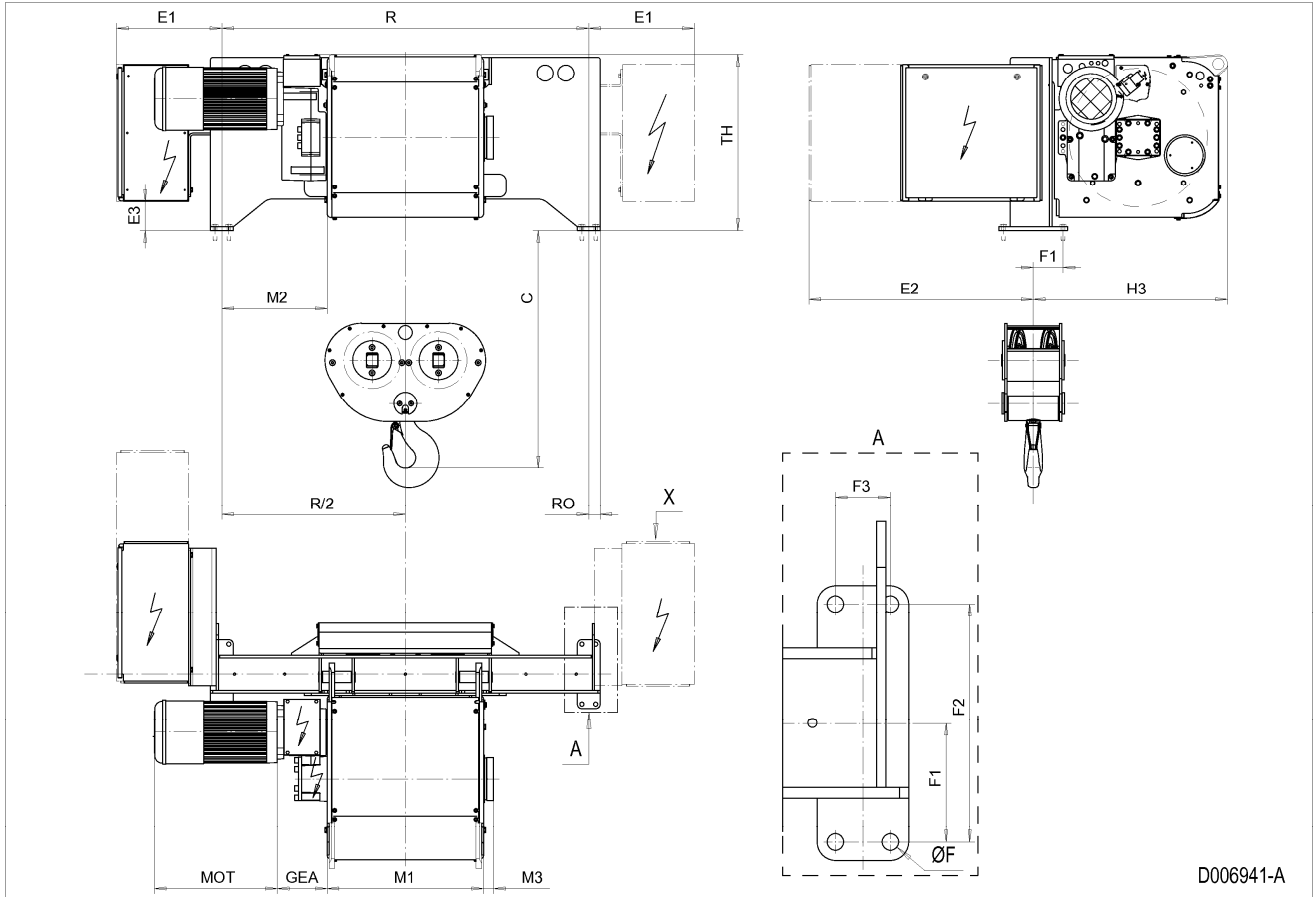

97 FIXED HOIST NE, REEVING: 26

Hoist dimensions

HOL m	HOL* m	Length code	R mm	M1 mm	M2 mm	Weight** kg
5.5	3	E	1600	682	459	1400
7	4.5	F	1600	832	384	1400
9.5	7	G	1600	1022	289	1500
13	10.5	H	2200	1272	464	1700
17	14.5	J	2200	1622	289	1800
21	18.5	K	2240	1922	164	1900
25.5	23	L	2240	2272	-10	2100
28.5	26	M	2790	2522	139	2300
32.5	30	N	2790	2822	-10	2400

*HOL with drum brake

**Presence of a drum brake will increase weight by 80 kgs.

Motor dimensions

Motor	P6	P7	P8	A7	S7	S8	SA
MOT (mm)	536	576	711	536	715	763	803
Weight (kg)	85	105	106	71	81	97	120

Trolley dimensions

C	ØF	E1	E2	E3	F1	F2	F3	GEA	H3	M3	RO
1079	18	460	979	126	129.5	260	60	218	847	44	50
TH											
769											

D006942_A
102579

Note: All dimensions in mm.

Note: Weight calculated with P6 motor.

Note: X points the location for an auxiliary electrical cubicle.

Fixed Hoist NE, REEVING: 26

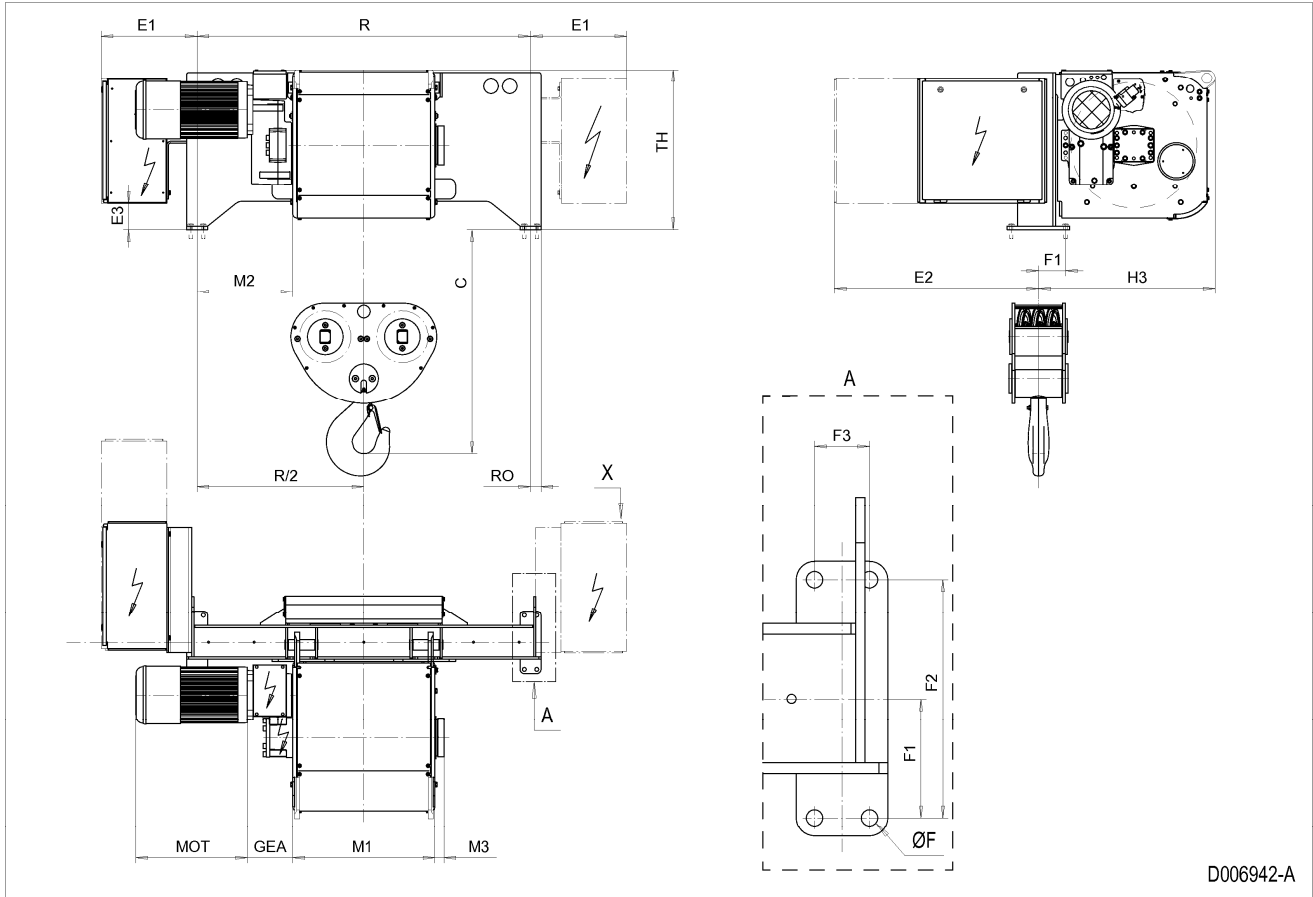

D006942-A

98 FIXED HOIST NE, REEVING: 28

Hoist dimensions

HOL m	HOL* m	Length code	R mm	M1 mm	M2 mm	Weight** kg
5.5	3.5	F	1600	832	384	1500
7	5	G	1600	1022	289	1600
9.5	7.5	H	2200	1272	464	1800
13	11	J	2200	1622	289	1900
15.5	13.5	K	2240	1922	164	2100
19	17	L	2240	2272	-10	2200
21.5	19.5	M	2790	2522	139	2400
24.5	22.5	N	2790	2822	-10	2600

*HOL with drum brake

**Presence of a drum brake will increase weight by 80 kgs.

Motor dimensions

Motor	P6	P7	P8	A7	S7	S8	SA
MOT (mm)	536	576	711	536	715	763	803
Weight (kg)	85	105	106	71	81	97	120

Trolley dimensions

C	ØF	E1	E2	E3	F1	F2	F3	GEA	H3	M3	RO
1206	18	460	979	126	129.5	260	60	218	847	44	50
TH											
769											

D006943_A
102580

Note: All dimensions in mm.

Note: Weight calculated with P6 motor.

Note: X points the location for an auxiliary electrical cubicle.

Fixed Hoist NE, REEVING: 28

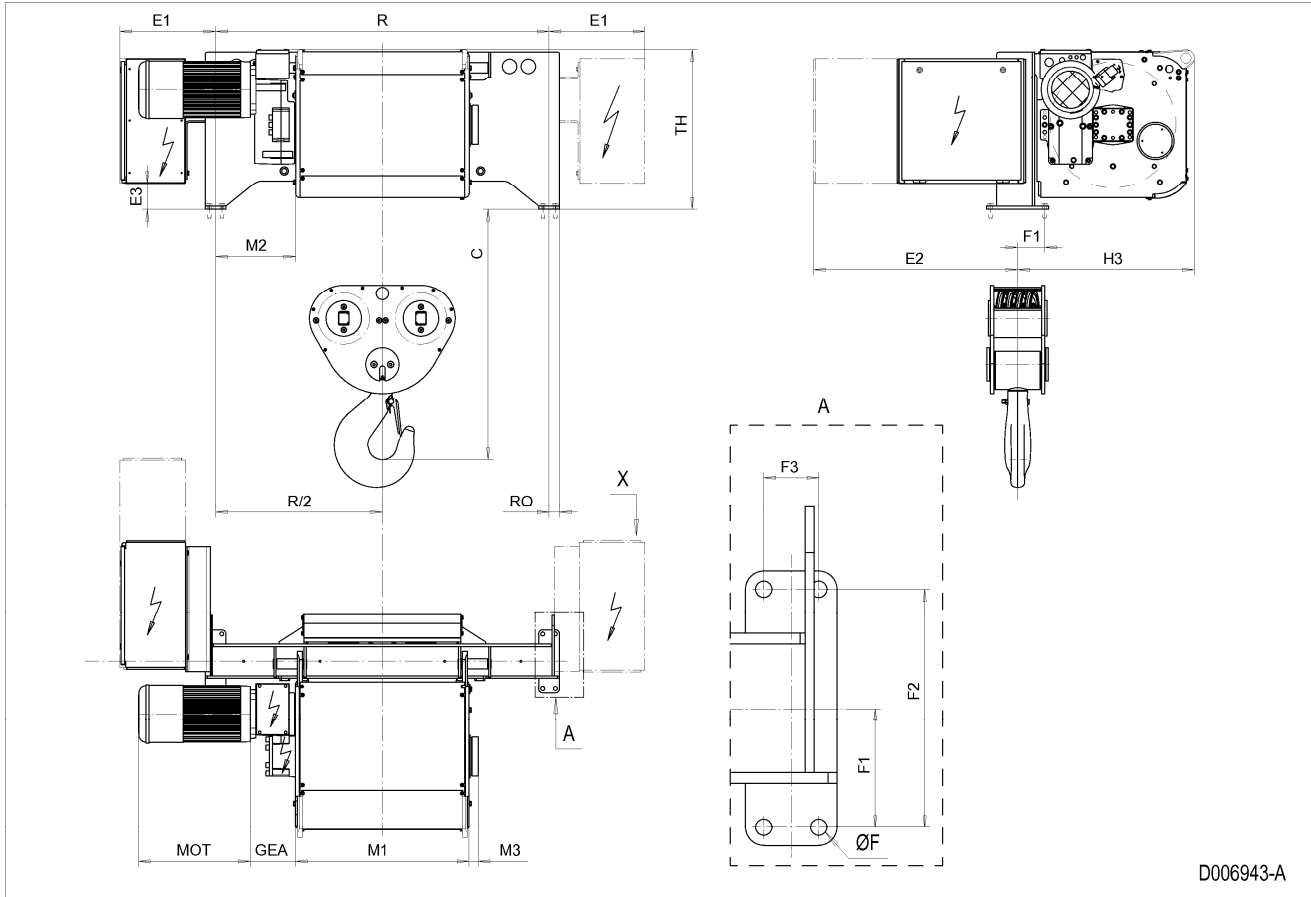

99 FIXED HOIST NF, REEVING: 22

Hoist dimensions

HOL m	HOL* m	Length code	R mm	M1 mm	M2 mm	Weight** kg
15.5	9	F	1700	832	434	1400
20.5	14	G	1700	1022	339	1500
27.5	21	H	2400	1272	565	1600
37.5	31	J	2400	1622	389	1800
46	39.5	K	3100	1922	339	2000
55.5	49	L	3100	2272	414	2200
62.5	56	M	3800	2522	840	2400
71	64.5	N	3800	2822	690	2600

*HOL with drum brake

**Presence of a drum brake will increase weight by 80 kgs.

Motor dimensions

Motor	P6	P7	A7	S7	S8	SA
MOT (mm)	536	576	536	715	763	803
Weight (kg)	85	105	71	81	97	120

Trolley dimensions

C	ØF	E1	E2	E3	F1	F2	F3	GEA	H3	M3	RO
918	18	488	941	122	220	540	70	218	871	44	92
TD	TH										
272	463										

D006944_A

102581

Note: All dimensions in mm.

Note: Weight calculated with P6 motors.

Note: The larger electrical cubicle is required with P7 motors.

Fixed Hoist NF, REEVING: 22

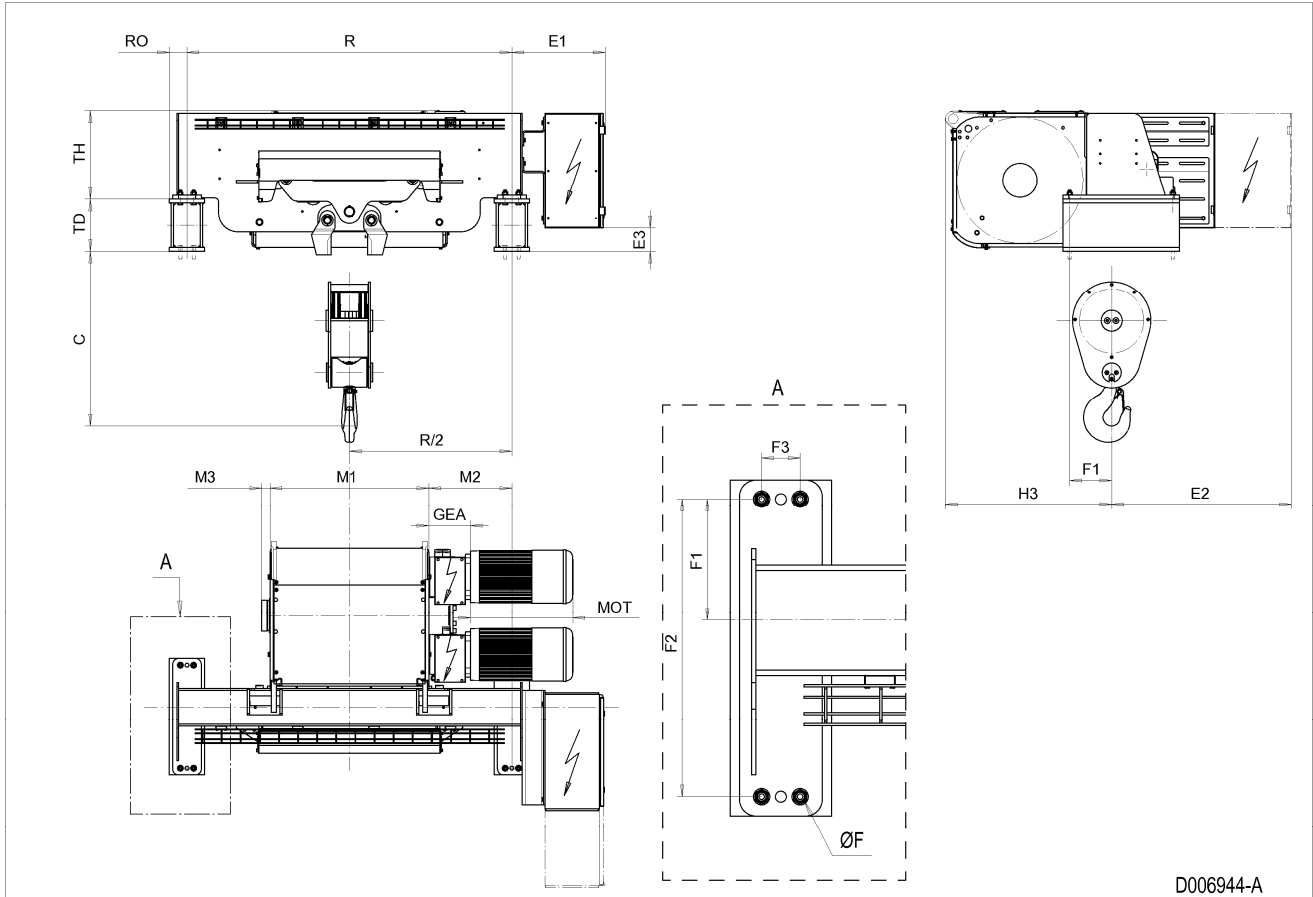

100 FIXED HOIST NF, REEVING: 24

Hoist dimensions

HOL m	HOL* m	Length code	R mm	M1 mm	M2 mm	Weight** kg
7.5	4	F	1700	832	434	1500
10	6.5	G	1700	1022	339	1500
13.5	10	H	2400	1272	565	1700
18.5	15	J	2400	1622	389	1800
23	19.5	K	3100	1922	339	2100
27.5	24	L	3100	2272	414	2200
31	27.5	M	3800	2522	840	2500
35.5	32	N	3800	2822	690	2600

*HOL with drum brake

**Presence of a drum brake will increase weight by 80 kgs.

Motor dimensions

Motor	P6	P7	A7	S7	S8	SA
MOT (mm)	536	576	536	715	763	803
Weight (kg)	85	105	71	81	97	120

Trolley dimensions

C	ØF	E1	E2	E3	F1	F2	F3	GEA	H3	M3	RO
1263	18	488	941	122	220	540	70	218	871	44	92
TD	TH										
272	463										

D006945_A

102582

Note: All dimensions in mm.

Note: Weight calculated with P6 motors.

Note: The larger electrical cubicle is required with P7 motors.

Fixed Hoist NF, REEVING: 24

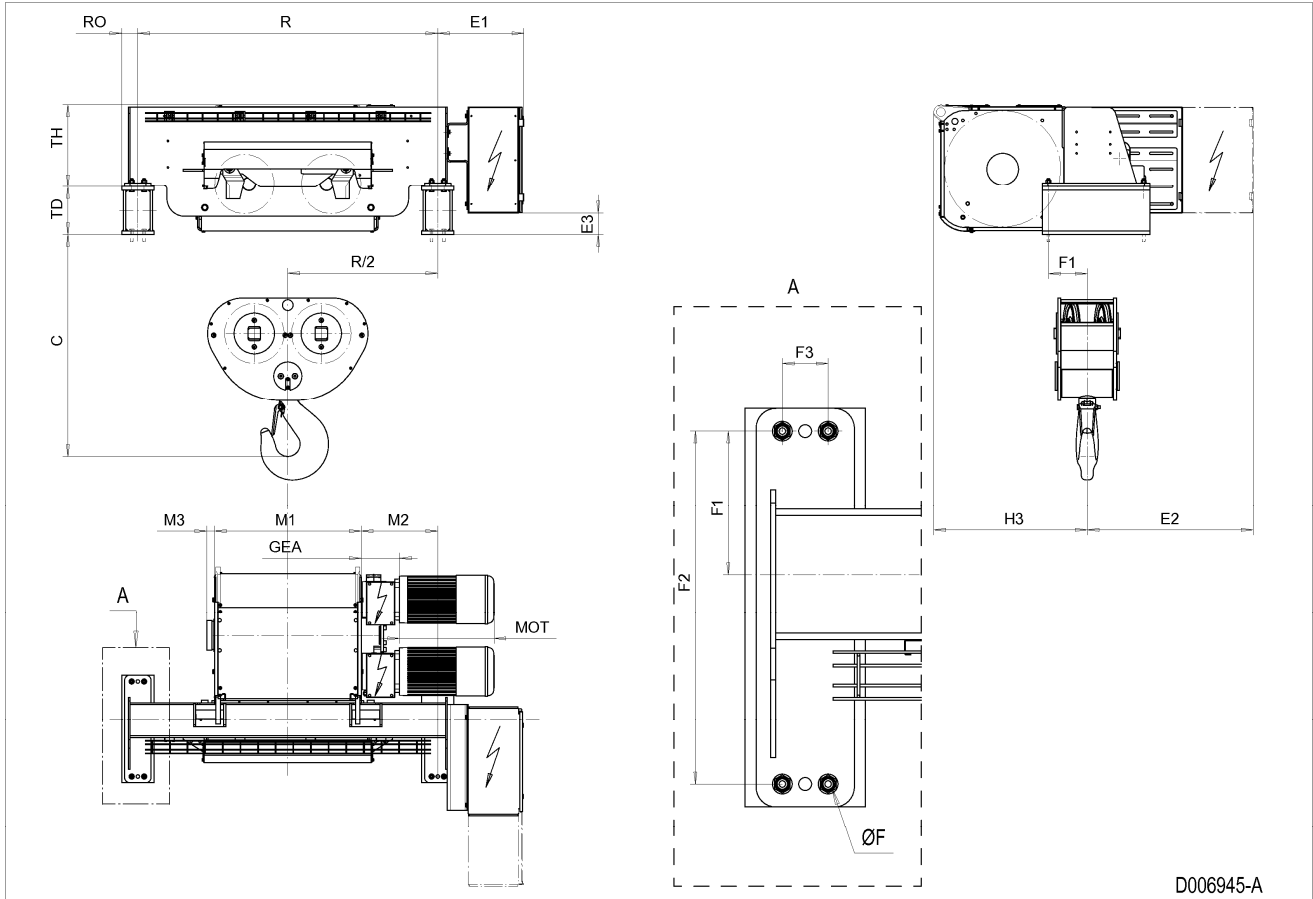

101 FIXED HOIST NF, REEVING: 26

Hoist dimensions

HOL m	HOL* m	Length code	R mm	M1 mm	M2 mm	Weight** kg
5	2.5	F	1700	832	434	1600
6.5	4	G	1700	1022	339	1700
9	6.5	H	2400	1272	565	1900
12.5	10	J	2400	1622	389	2000
15	12.5	K	3100	1922	339	2400
18.5	16	L	3100	2272	414	2600
20.5	18	M	3800	2522	840	3000
23.5	21	N	3800	2822	690	3100

*HOL with drum brake

**Presence of a drum brake will increase weight by 80 kgs.

Motor dimensions

Motor	P6	P7	A7	S7	S8	SA
MOT (mm)	536	576	536	715	763	803
Weight (kg)	85	105	71	81	97	120

Trolley dimensions

C	ØF	E1	E2	E3	F1	F2	F3	GEA	H3	M3	RO
1339	18	488	941	122	220	540	70	218	871	44	92
TD	TH										
330	405										

D006946_A
102583

Note: All dimensions in mm.

Note: Weight calculated with P6 motors.

Note: The larger electrical cubicle is required with P7 motors.

Fixed Hoist NF, REEVING: 26

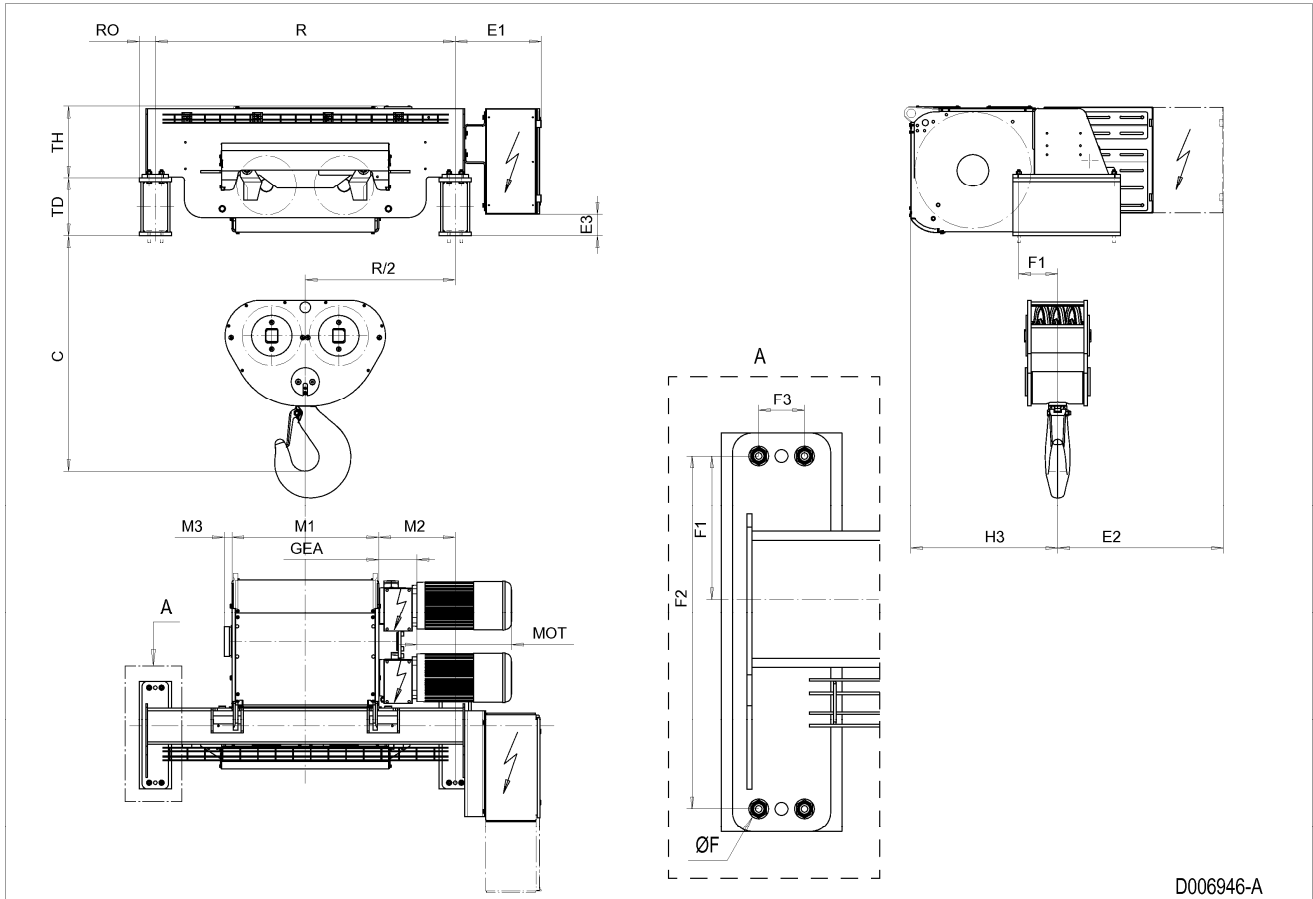

102 FIXED HOIST NF, REEVING: 28

Hoist dimensions

HOL m	HOL* m	Length code	R mm	M1 mm	M2 mm	Weight** kg
6.5	4.5	H	2400	1272	565	2000
9	7	J	2400	1622	389	2200
11	9	K	3100	1922	339	2600
13.5	11.5	L	3100	2272	414	2700
15.5	13.5	M	3800	2522	840	3100
17.5	15.5	N	3800	2822	690	3200

*HOL with drum brake

**Presence of a drum brake will increase weight by 80 kgs.

Motor dimensions

Motor	P6	P7	A7	S7	S8	SA
MOT (mm)	536	576	536	715	763	803
Weight (kg)	85	105	71	81	97	120

Trolley dimensions

C	ØF	E1	E2	E3	F1	F2	F3	GEA	H3	M3	RO
1430	18	488	941	122	220	540	70	218	871	44	92
TD	TH										
330	405										

D006947_A
102584

Note: All dimensions in mm.

Note: Weight calculated with P6 motors.

Note: The larger electrical cubicle is required with P7 motors.

Fixed Hoist NF, REEVING: 28

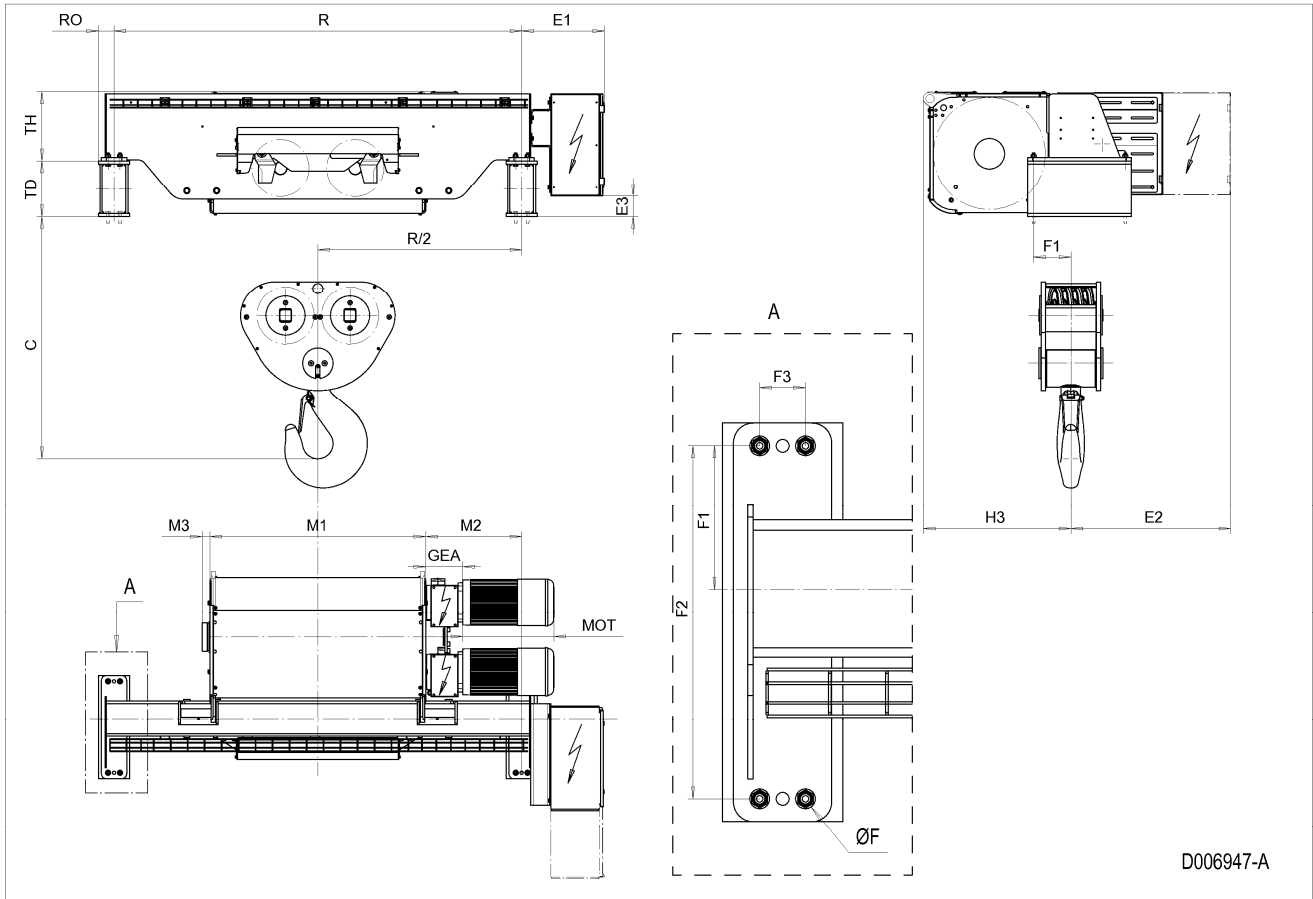

MACHINERY HOIST

103 MACHINERY HOIST NBM1V, REEVING: M1

Hoist dimensions

HOL m	Length code	M1 mm	H2 mm	T1 mm	Weight kg
24	A	318	182	270	95
38	C	448	288	400	105

Motor dimensions

Motor	P1	P2	P3	A3	S3
MOT (mm)	382	442	472	442	522
Weight (kg)	21	31	35	32	28

Trolley dimensions

ØF	E1	GEA	H1	M2	T2	TH	TO				
14	291	114	28	24	300	386	40				

D002083_A
062495

Note: All dimensions in mm.

Note: Weight calculated with P1 motor.

Note: Motor P1 is unavailable for load classes 600 and 800 kg.

Note: Max rope angle from drum groove +/- 4 degrees.

Machinery Hoist NBM1V, REEVING: M1

Note: Rope directions presented in detail views: A: down, B: left, C: up, D: right.

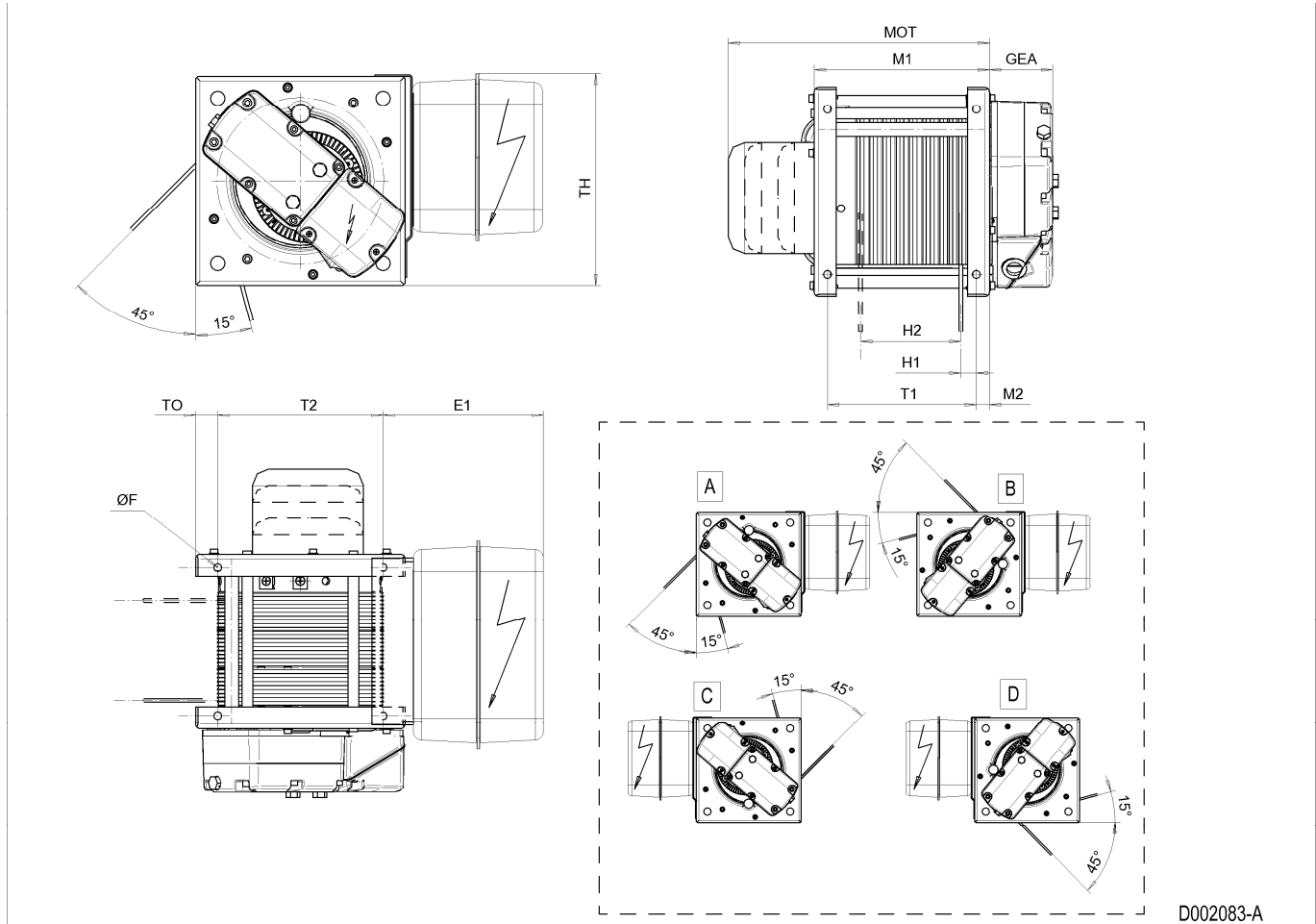

104 MACHINERY HOIST NBM2V, REEVING: M2, ROPES TO SAME DIRECTION

Hoist dimensions

HOL m	Length code	M1 mm	H2 mm	T1 mm	Weight kg
7	A	318	53	270	95
15	C	448	118	400	105

Motor dimensions

Motor	P1	P2	P3	A3	S3
MOT (mm)	382	442	472	442	522
Weight (kg)	21	31	35	32	28

Trolley dimensions

ØF	E1	GEA	H1	H3	M2	T2	TH	TO			
14	291	114	28	74	24	300	386	40			

D002085_A

062496

Note: All dimensions in mm.

Note: Weight calculated with P1 motor.

Note: Motor P1 is unavailable for load classes 600 and 800 kg.

Note: Rope 1 closer to the gearbox.

Note: max rope angle from drum groove +/- 4 degrees.

Machinery Hoist NBM2V, REEVING: , Ropes To Same Direction

Note: Rope directions presented in detail view: A: down, B: left, C: up, D: right.

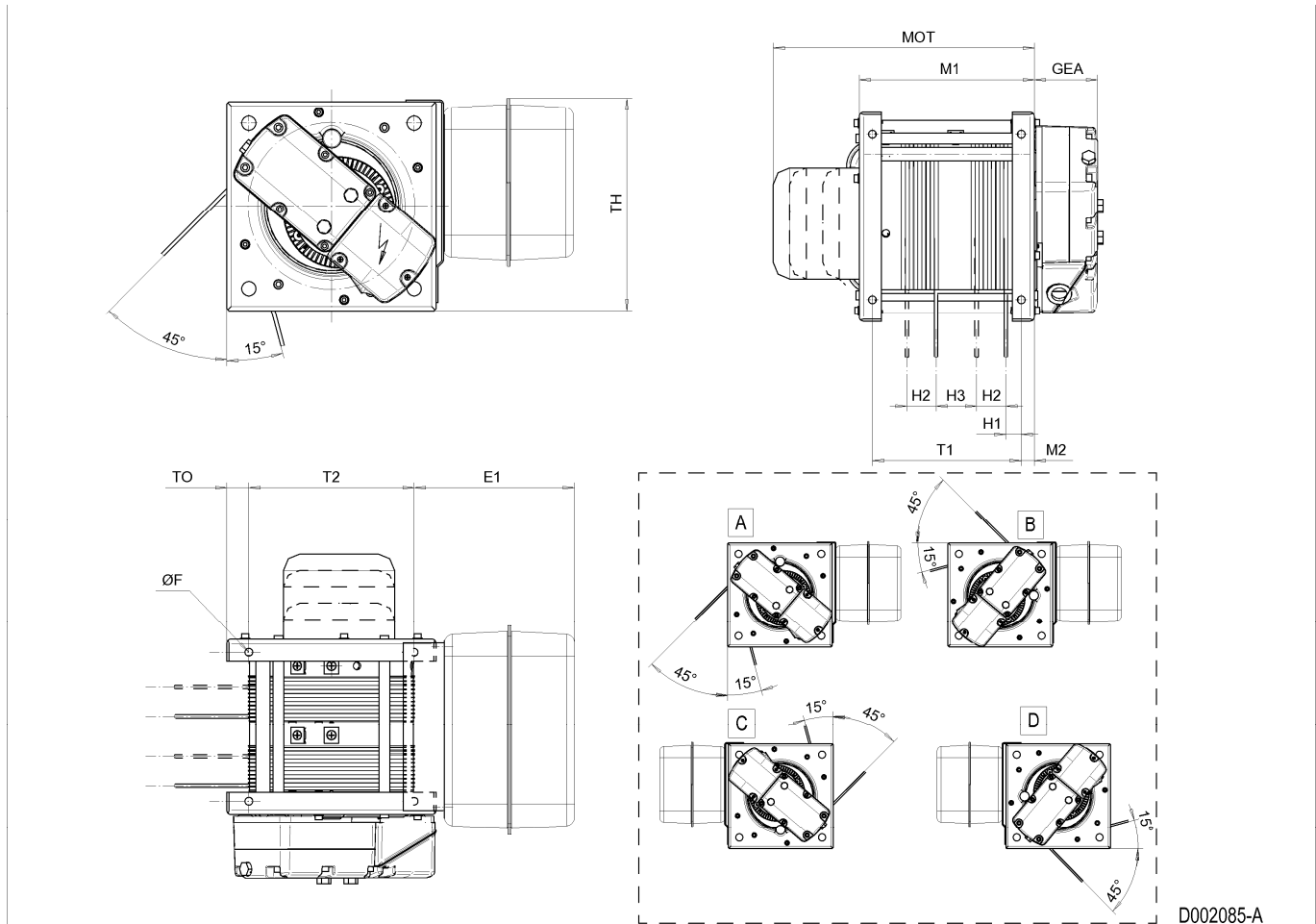

105 MACHINERY HOIST NBM2V, REEVING: M2, ROPES TO OPPOSITE DIRECTIONS

Hoist dimensions

HOL m	Length code	M1 mm	H2 mm	T1 mm	Weight kg
7	A	318	53	270	95
15	C	448	118	400	105

Motor dimensions

Motor	P1	P2	P3	A3	S3
MOT (mm)	382	442	472	442	522
Weight (kg)	21	31	35	32	28

Trolley dimensions

ØF	E1	E2	GEA	H1	H3	M2	T2	TH	TO		
14	291	307	114	28	74	24	300	386	40		

D002084_A

062561

Note: All dimensions in mm.

Note: Weight calculated with P1 motor.

Note: Motor P1 is unavailable for load classes 600 and 800 kg.

Note: Both ropes within the allowed rope angle!

Note: Max rope angle from drum groove +/- 4 degrees.

Machinery Hoist NBM2V, REEVING: M2, Ropes To Opposite Directions

Note: Rope directions presented in detail views: A: rope 1 down, B: rope 1 left, C: rope 2 up, D: rope 2 right.
 Note: Detail view E shows the optional and transport position of the cubicle.

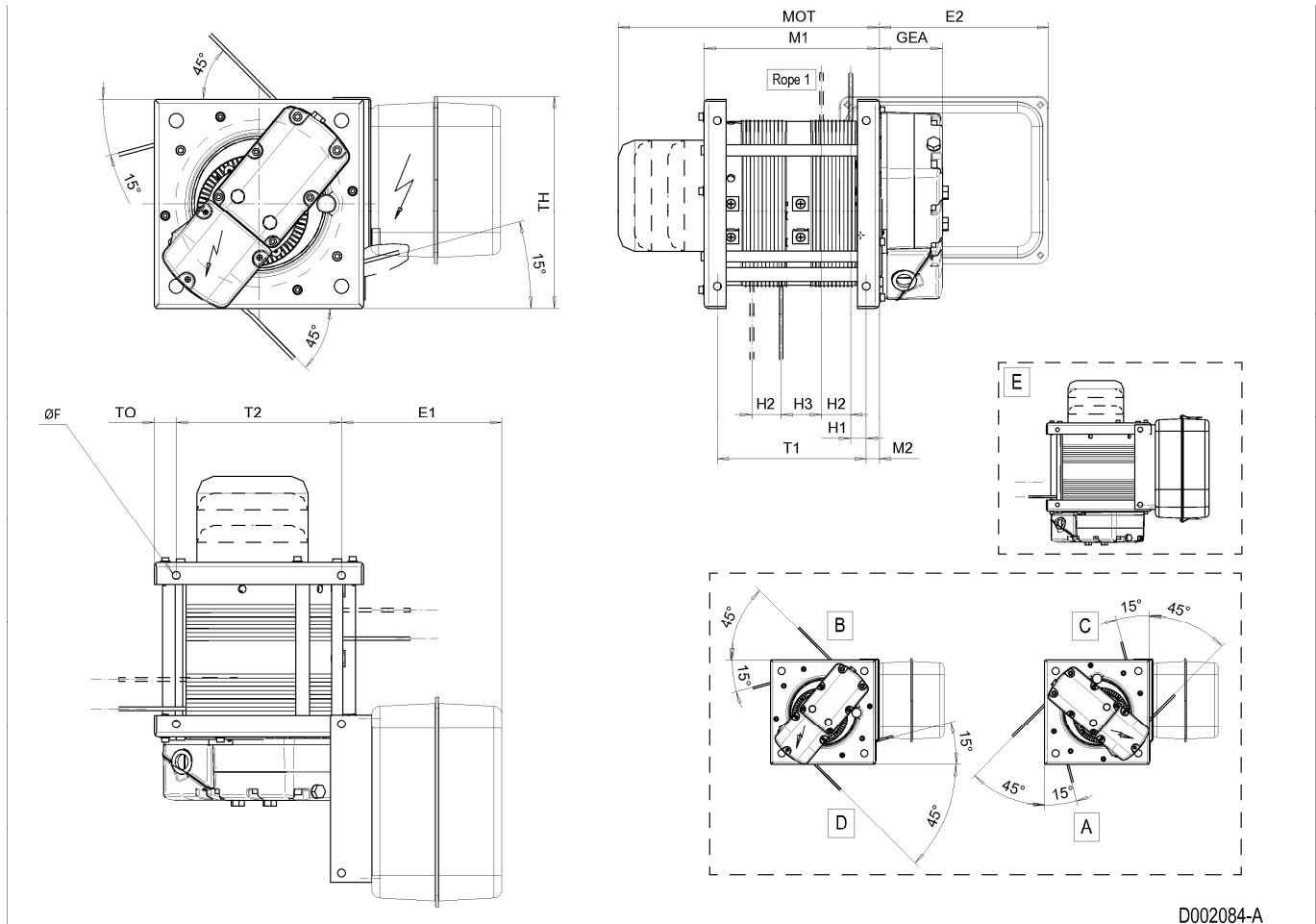

D002084-A

106 MACHINERY HOIST NCM1V, REEVING: M1

Hoist dimensions

HOL m	Length code	M1 mm	H2 mm	T1 mm	Weight kg
24	B	350	196	300	140
36	C	450	292	400	150
48	D	550	392	500	160
62	E	670	506	620	170

Motor dimensions

Motor	P3	P4	A3	S3	S5
MOT (mm)	470	571	440	520	599
Weight (kg)	35	53	32	28	53

Trolley dimensions

ØF	E1	GEA	H1	M2	T2	TH	TO				
18	294	119	40	25	350	456	43				

D002108_A
062500

Note: All dimensions in mm.

Note: Weight calculated with P3 motor.

Note: Motor S5 is unavailable for load class 1600 kg.

Note: Max rope angle from drum groove +/- 4 degrees.

Machinery Hoist NCM1V, REEVING: M1

Note: Rope directions presented in detail views: A: down, B: left, C: up, D: right.

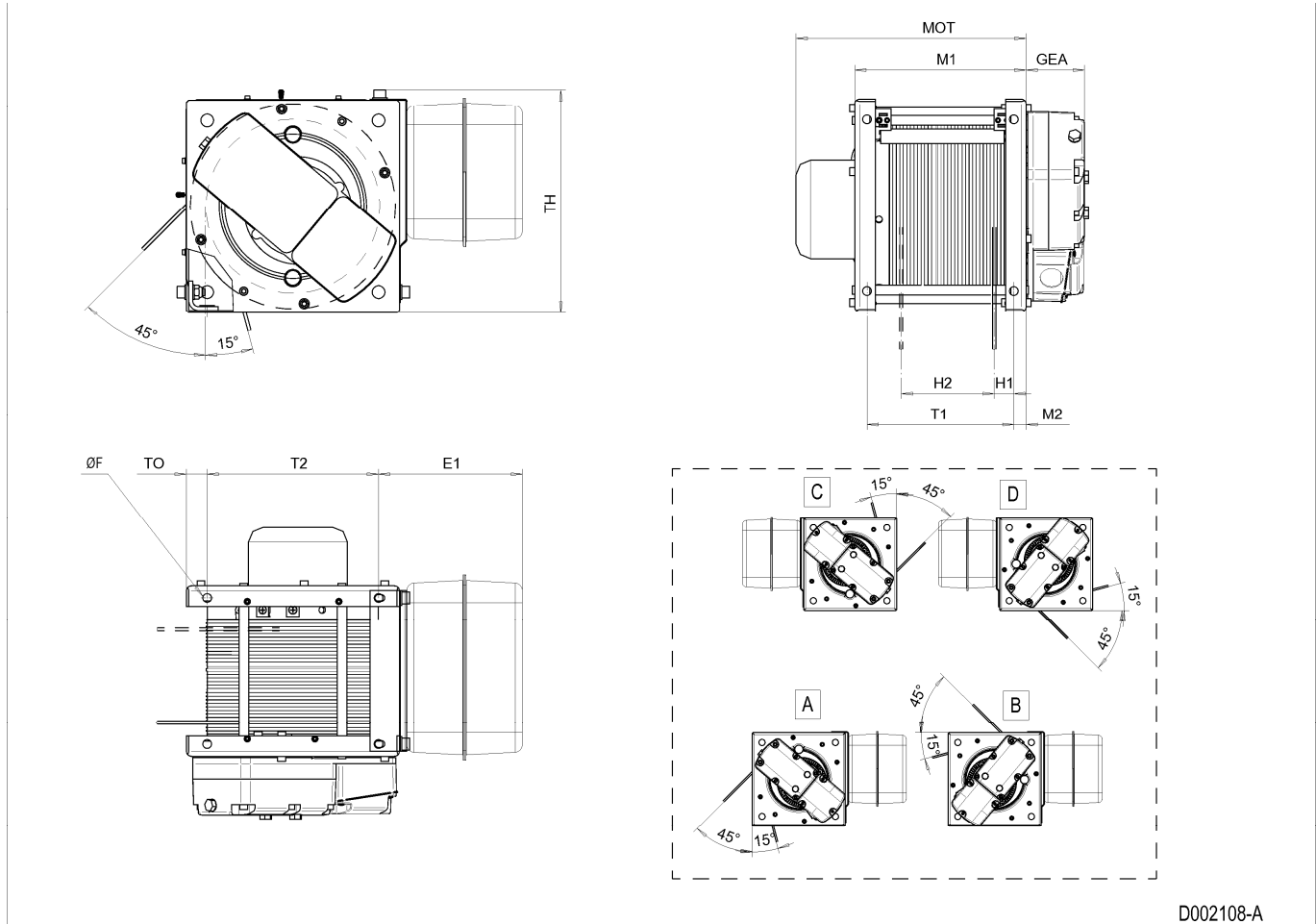

D002108-A

107 MACHINERY HOIST NCM2V, REEVING: M2, ROPES TO SAME DIRECTION

Hoist dimensions

HOL m	Length code	M1 mm	H2 mm	T1 mm	Weight kg
9.5	B	350	62	300	140
17	C	450	112	400	150
25	D	550	162	500	160
34	E	670	222	620	170

Motor dimensions

Motor	P3	P4	A3	S3	S5
MOT (mm)	470	571	440	520	599
Weight (kg)	35	53	32	28	53

Trolley dimensions

ØF	E1	GEA	H1	H3	M2	T2	TH	TO			
18	294	119	40	80	25	350	456	43			

D002110_A
062505

Note: All dimensions in mm.

Note: Weight calculated with P3 motor.

Note: Motor S5 is unavailable for load class 1600 kg.

Note: Max rope angle from drum groove +/- 4 degrees.

Machinery Hoist NCM2V, REEVING: M2, Ropes To Same Direction

Note: Rope directions presented in detail view: A: down, B: left, C: up, D: right.

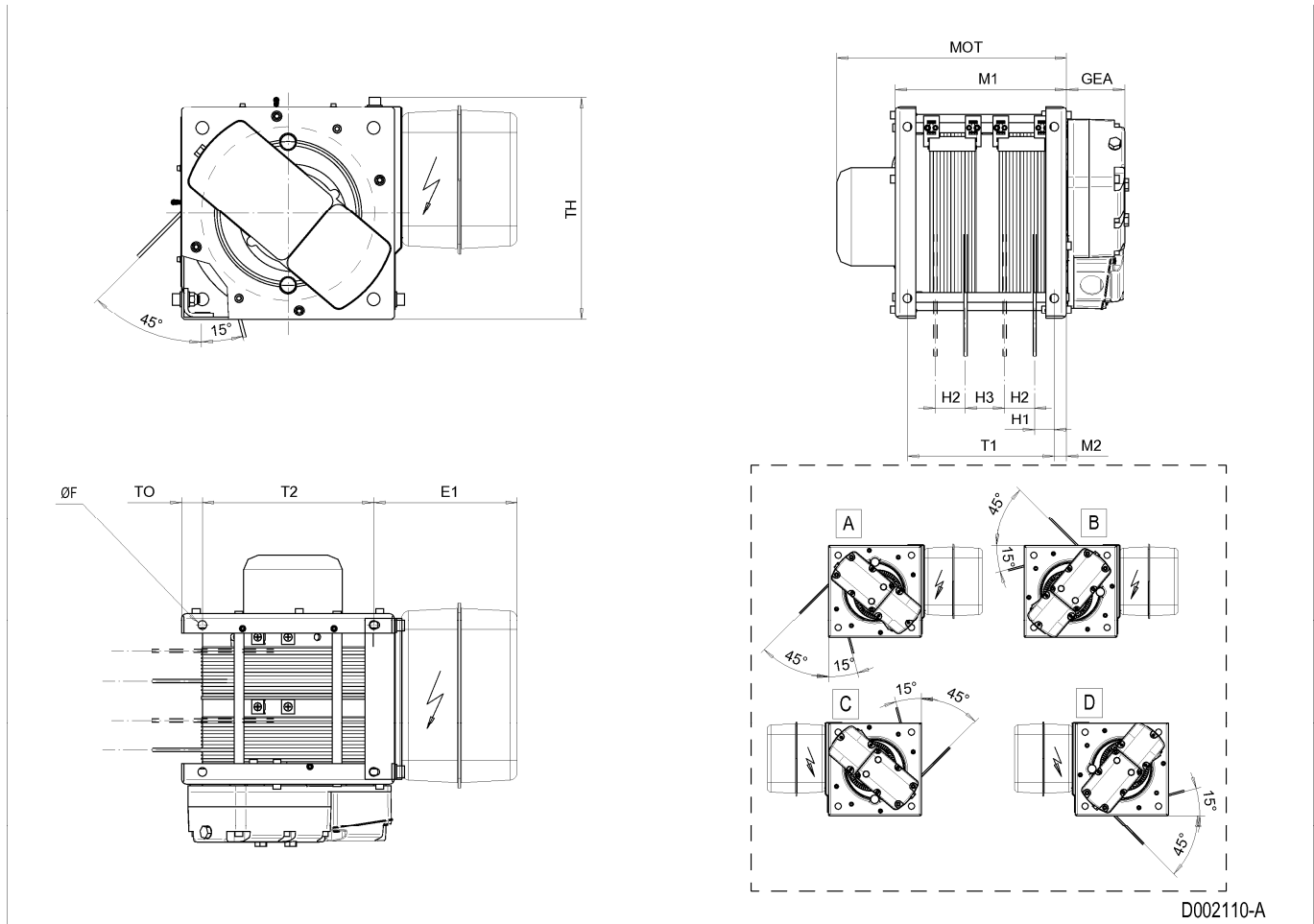

108 MACHINERY HOIST NCM2V, REEVING: M2, ROPES TO OPPOSITE DIRECTIONS

Hoist dimensions

HOL m	Length code	M1 mm	H2 mm	T1 mm	Weight kg
9.5	B	350	62	300	140
17	C	450	112	400	150
25	D	550	162	500	160
34	E	670	222	620	170

Motor dimensions

Motor	P3	P4	A3	S3	S5
MOT (mm)	470	571	440	520	599
Weight (kg)	35	53	32	28	53

Trolley dimensions

ØF	E1	E2	GEA	H1	H3	M2	T2	TH	TO		
18	296	308	119	40	80	25	350	456	43		

D002109_A
062501

Note: All dimensions in mm.

Note: Weight calculated with P3 motor.

Note: Motor S5 is unavailable for load class 1600 kg.

Note: Max rope angle from drum groove +/- 4 degrees.

Note: Rope 1 closer to the gearbox.

Machinery Hoist NCM2V, REEVING: M2, Ropes To Opposite Directions

Note: Rope directions presented in detail view: A: rope 1 down, B: rope 1 left, C: rope 2 up, D: rope 2 right.

Note: Detail view E shows the optional and transport position of the cubicle.

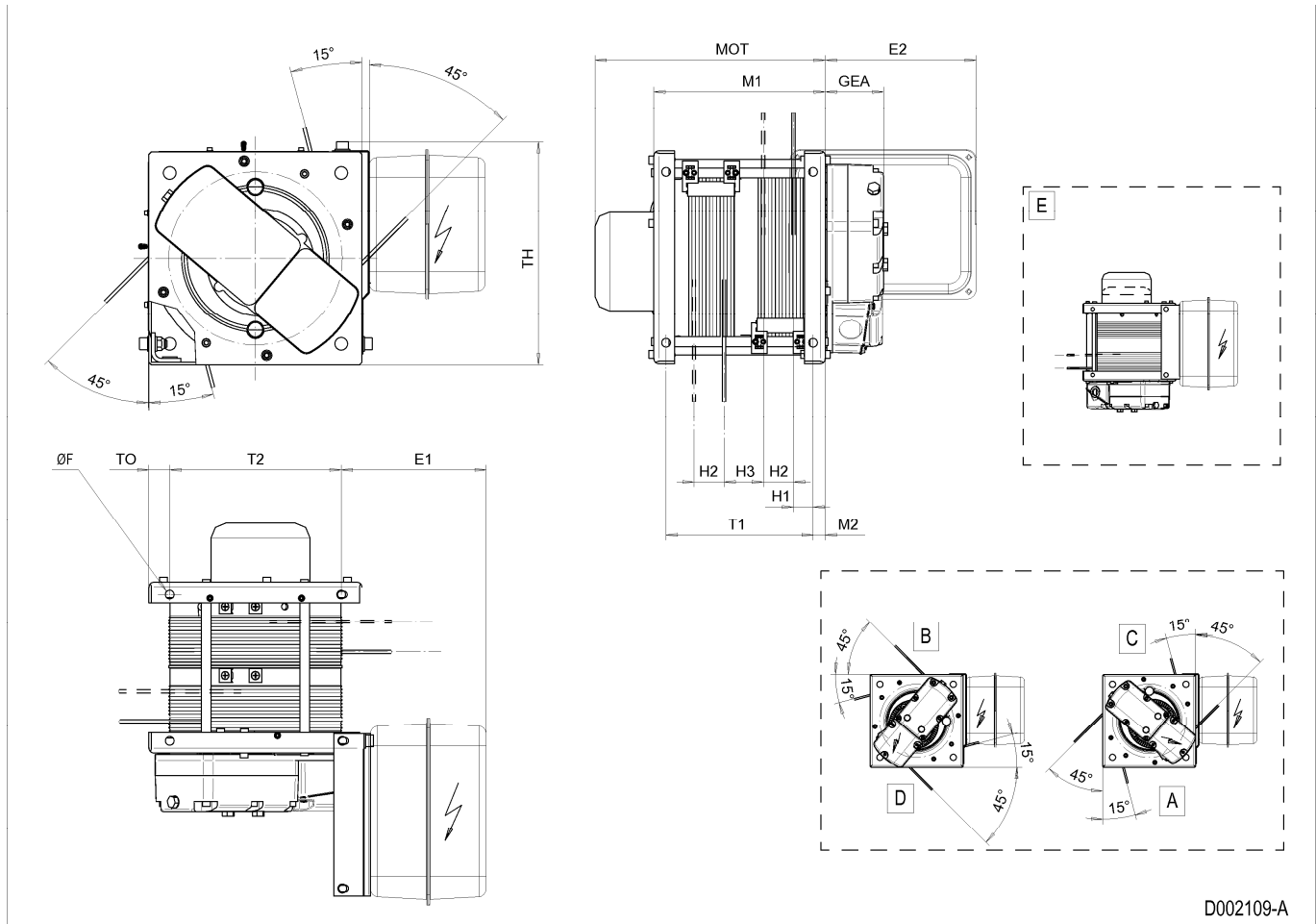

D002109-A

109 MACHINERY HOIST NDM1V, REEVING: M1

Hoist dimensions

HOL m	Length code	M1 mm	H2 mm	T1 mm	Weight kg
36	D	552	352	490	315
48	E	672	472	610	330
64	F	822	622	760	350
82	G	1012	812	950	370

Motor dimensions

Motor	P5	P6	P7	A5	S5	S7
MOT (mm)	575	575	615	495	603	754
Weight (kg)	58	85	105	45	53	81

Trolley dimensions

ØF	E1	GEA	H1	M2	T2	TH	TO				
22	391	146	54	31	400	541	58				

D002138_A
062940

Note: All dimensions in mm.

Note: Weight calculated with P5 motor.

Note: Motor S7 is unavailable for load class 3150 kg.

Note: Max rope angle from drum groove +/- 4 degrees.

Machinery Hoist NDM1V, REEVING: M1

Note: Rope directions presented in detail view: A: down, B: left, C: up, D: right.

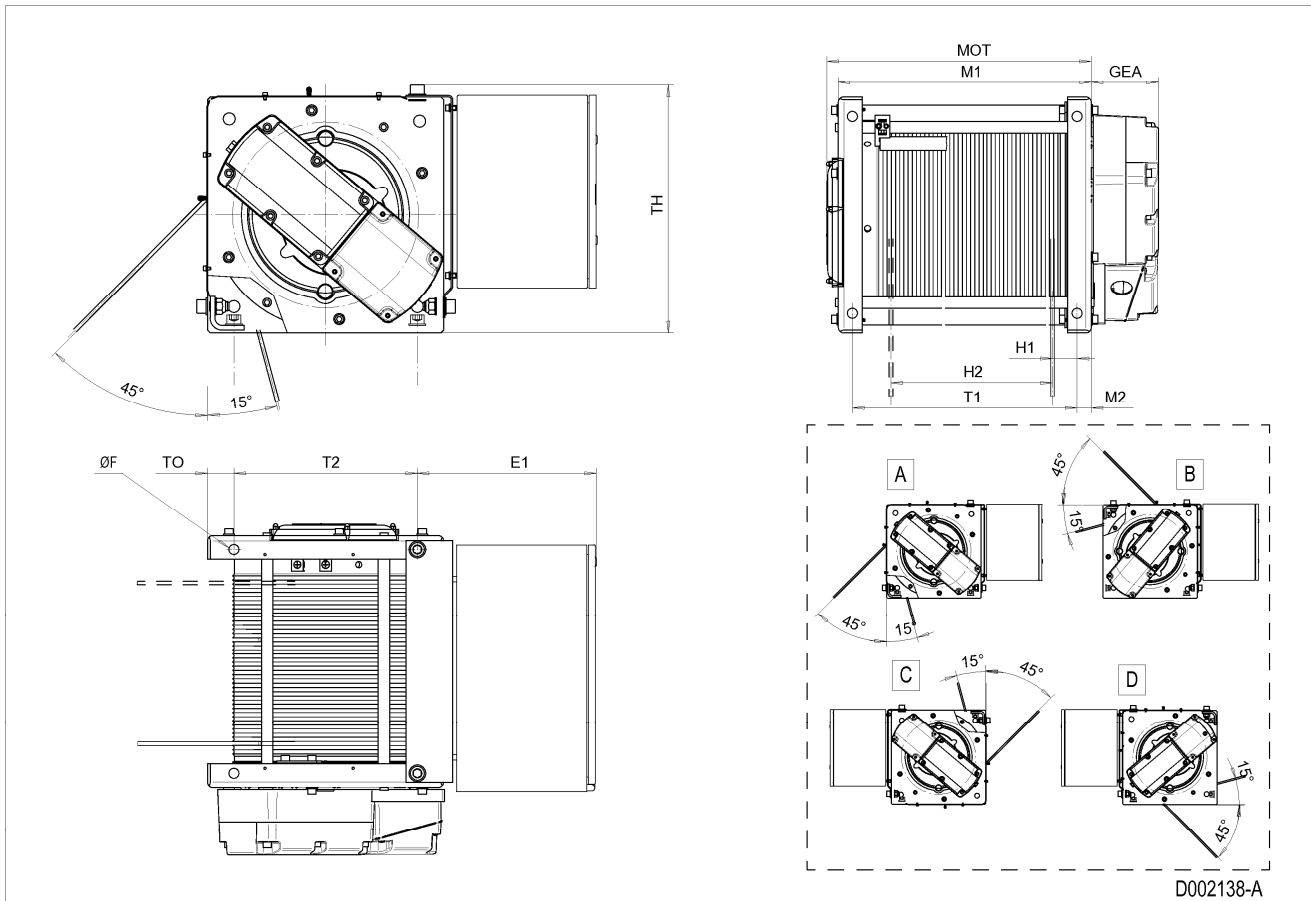

110 MACHINERY HOIST NDM2V, REEVING: M2, ROPES TO SAME DIRECTION

Hoist dimensions

HOL m	Length code	M1 mm	H2 mm	T1 mm	Weight kg
18	D	552	128	490	315
27	E	672	188	610	330
38	F	822	263	760	350
50	G	1012	358	950	370

Motor dimensions

Motor	P5	P6	P7	A5	S5	S7
MOT (mm)	575	575	615	495	603	754
Weight (kg)	58	85	105	45	53	81

Trolley dimensions

ØF	E1	E2	GEA	H1	H3	M2	T2	TH	TO		
22	391	499	146	65	99	31	400	541	58		

D002137_A
062942

Note: All dimensions in mm.

Note: Weight calculated with P5 motor.

Note: Motor S7 is unavailable for load class 3150 kg.

Note: Max rope angle from drum groove +/- 4 degrees.

Machinery Hoist NDM2V, REEVING: M2, Ropes To Same Direction

Note: Rope directions presented in detail view: A: down, B: left, C: up, D: right.

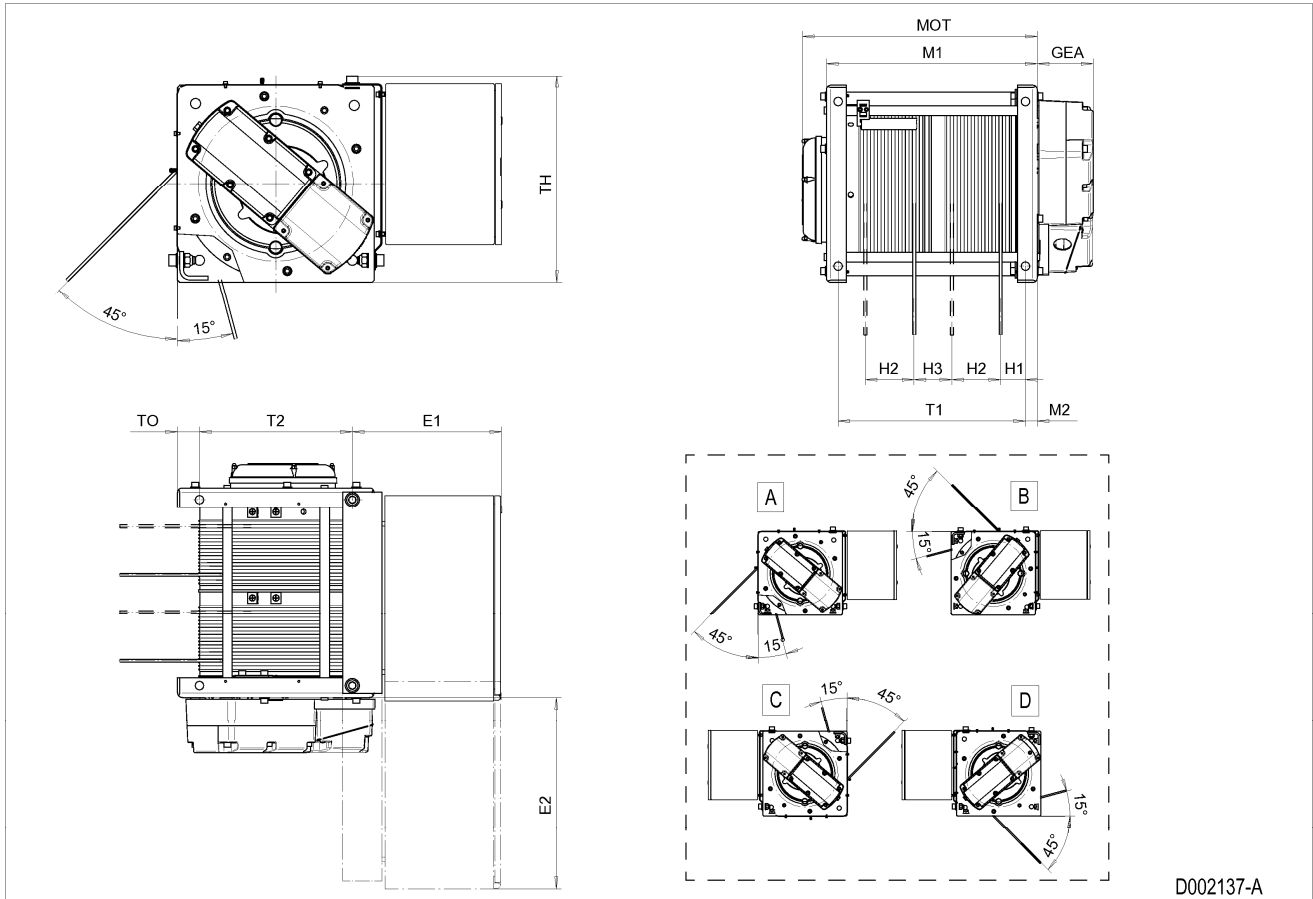

111 MACHINERY HOIST NDM2V, REEVING: M2, ROPES TO OPPOSITE DIRECTIONS

Hoist dimensions

HOL m	Length code	M1 mm	H2 mm	T1 mm	Weight kg
18	D	552	128	490	315
27	E	672	188	610	330
38	F	822	263	760	350
50	G	1012	358	950	370

Motor dimensions

Motor	P5	P6	P7	A5	S5	S7
MOT (mm)	575	575	615	495	603	754
Weight (kg)	58	85	105	45	53	81

Trolley dimensions

ØF	E1	E2	GEA	H1	H3	M2	T2	TH	TO		
22	391	499	146	65	99	31	400	541	58		

D002139_A
062943

Note: All dimensions in mm.

Note: Weight calculated with P5 motor.

Note: Motor S7 is unavailable for load class 3150 kg.

Note: Rope 1 closer to the gearbox.

Note: Max rope angle from drum groove +/- 4 degrees.

Machinery Hoist NDM2V, REEVING: M2, Ropes To Opposite Directions

Note: Rope directions presented in detail view: A: rope 1 down, B: rope 1 left, C: rope 2 up, D: rope 2 right.

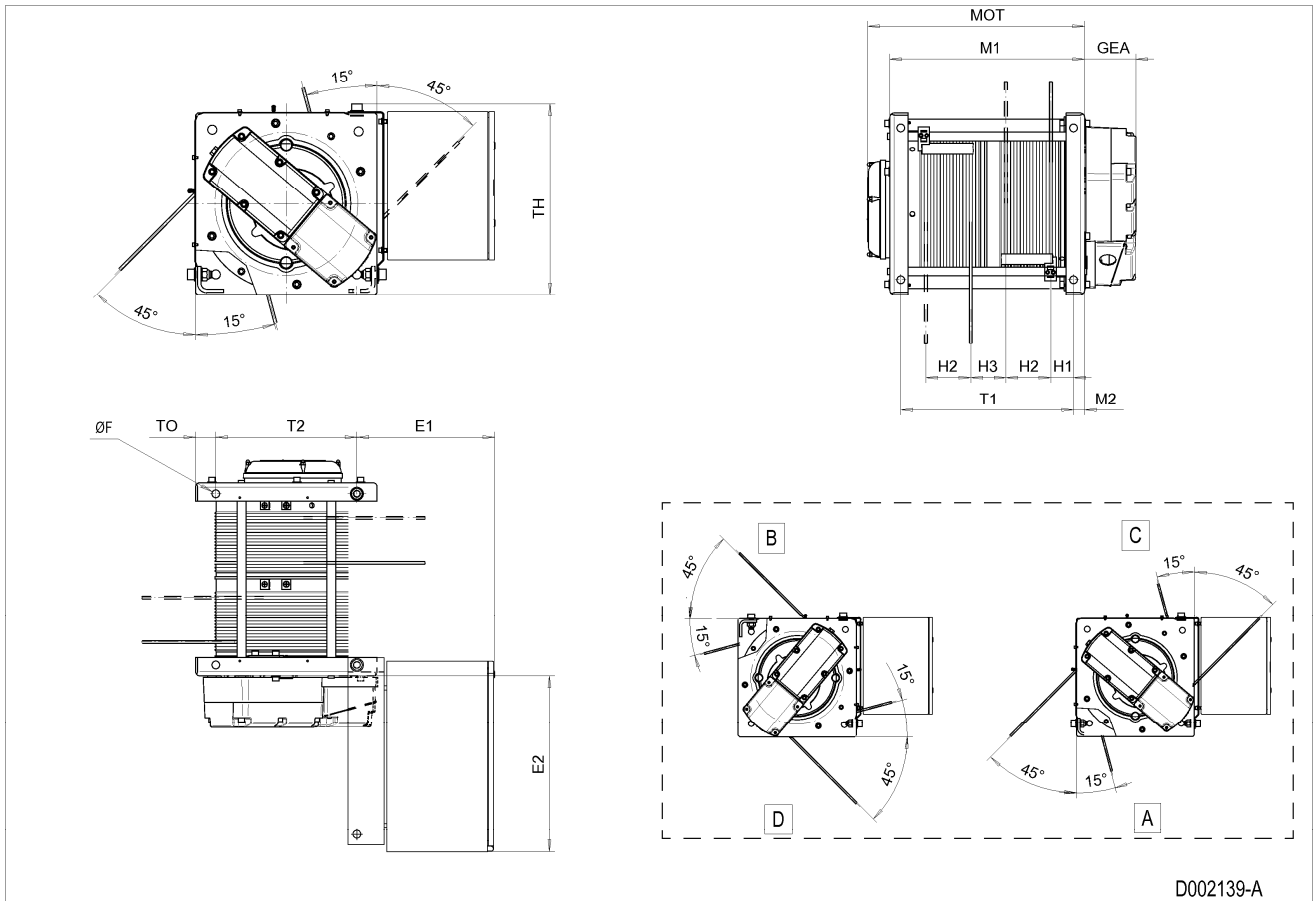

112 MACHINERY HOIST NEM1V, REEVING: M1

Hoist dimensions

HOL m	HOL* m	Length code	H2 mm	T1 mm	M1 mm	Weight** kg
32	22	C	286	400	466	600
43	33	D	385	500	566	630
56.5	46.5	E	506	620	686	660
73	63	F	654	770	836	700
94.5	84.5	G	846	960	1026	740
122.5	112.5	H	1097	1210	1276	810
161.5	151.5	J	1446	1560	1626	900
195	185	K	1746	1860	1926	980

*HOL with drum brake

**Presence of a drum brake will increase weight by 80 kgs.

Motor dimensions

Motor	P6	P7	P8	A7	S7	S8	SA
MOT (mm)	536	576	711	536	715	763	803
Weight (kg)	85	105	106	71	81	97	120

Trolley dimensions

ØF	E1	E2	GEA	H1	LIF	M2	M3	T2	T3	T4	TH
21	300	669	218	57	62	33	44	660	540	420	809
TO											
72											

D002433_A
063844

Note: All dimensions in mm.

Note: Weight calculated with P6 motor.

Note: Max rope angle from drum groove +/- 4 degrees.

Machinery Hoist NEM1V, REEVING: M1

Note: Rope directions presented in detail views: A: down, B: left, C: up, D: right.

Note: Detail view E for alternative mounting.

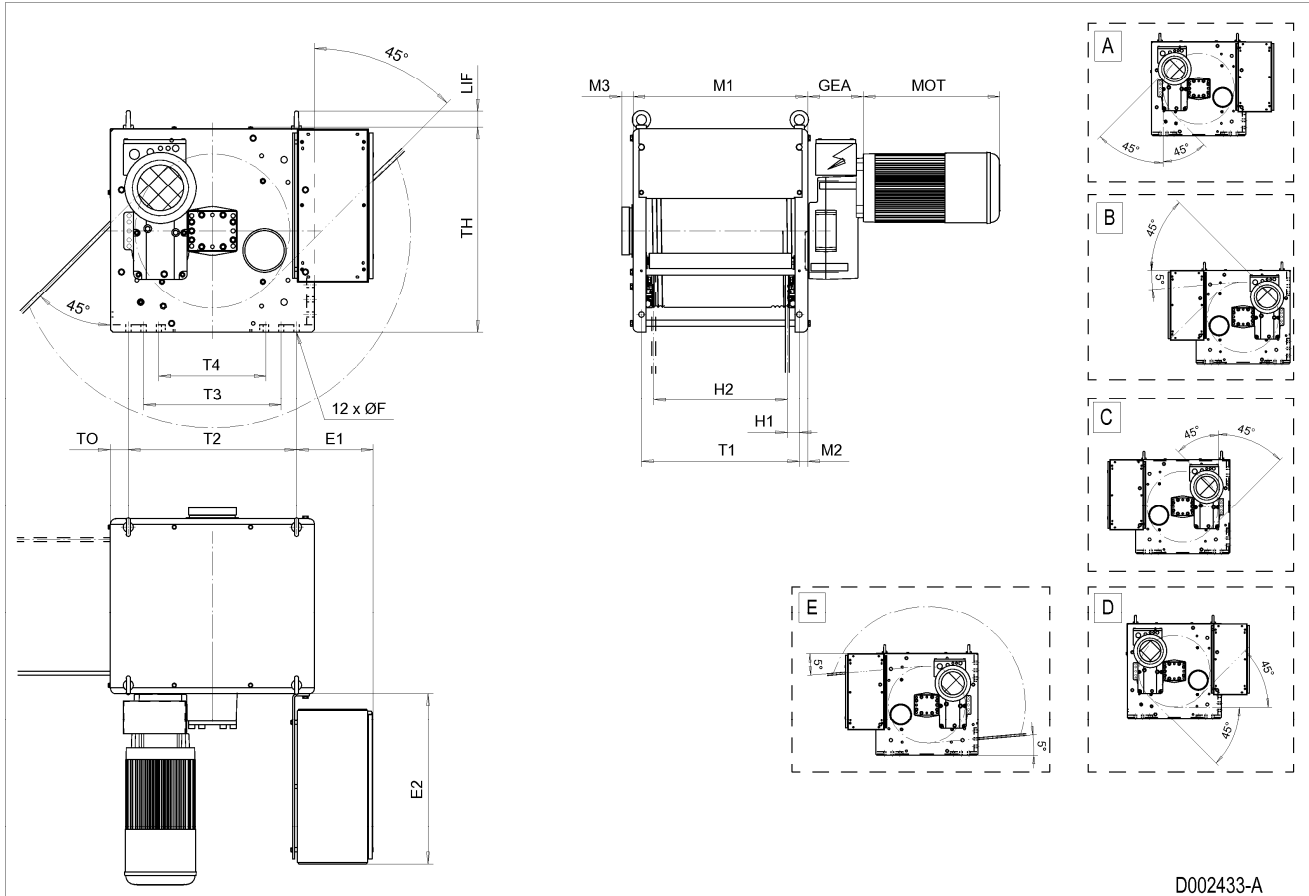

113 MACHINERY HOIST NEM2V, REEVING: M2

Hoist dimensions

HOL m	HOL* m	Length code	H2 mm	T1 mm	M1 mm	Weight** kg
37	23	E	242	620	686	660
48.5	34.5	F	317	770	836	700
63	49	G	412	960	1026	740
82	68	H	537	1210	1276	810
108.5	94.5	J	710	1560	1626	900
131.5	117.5	K	861	1860	1926	980
158.5	144.5	L	1037	2210	2276	1070
177.5	163.5	M	1162	2460	2526	1140
200.5	186.5	N	1312	2760	2826	1220

*HOL with drum brake

**Presence of a drum brake will increase weight by 80 kgs.

Motor dimensions

Motor	P6	P7	P8	A7	S7	S8	SA
MOT (mm)	536	576	711	536	715	763	803
Weight (kg)	85	105	106	71	81	97	120

Trolley dimensions

ØF	E1	E2	GEA	H1	H3	LIF	M2	M3	T2	T3	T4
21	308	669	218	53	30	62	33	44	660	540	420
TH	TO										
809	72										

D002411_A
063845

Note: All dimensions in mm.

Note: Weight calculated with P6 motor.

Note: Angle of rope 2 can variate 0-360 degrees.

Note: Max rope angle from drum groove +/- 4 degrees.

Machinery Hoist NEM2V, REEVING: M2

Note: Rope directions presented in detail views: A: down, B: left, C: up, D: right.

Note: Detail view E for alternative mounting and rope 1 angle.

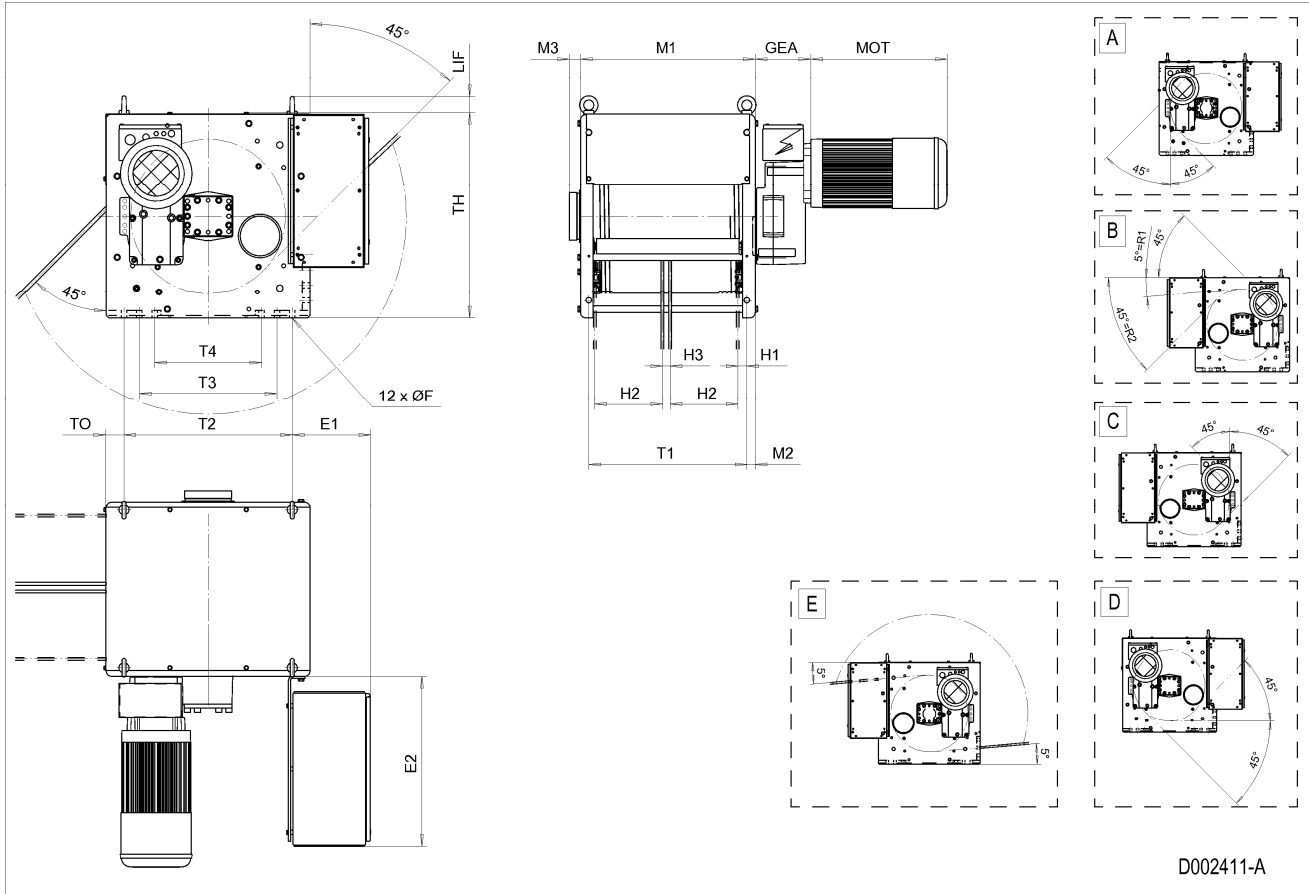

114 SOLO ELECTRICS IN EXTERNAL CUBICLE, NB/NC/ND LOW HEADROOM AND NORMAL HEADROOM HOISTS

Solo electrics in external cubicle increase the hoist overall dimensions. Variable dimension indicates the dimension that is extended by the reported value to produce the new hoist overall dimension ES due to the presence of solo electrics. See the appropriate variable dimensions from the data of the hoist in question.

Hoists not reported here don't have their overall dimensions affected by solo electrics.

NB/NC Hoists

Hoist	Case	ES mm
NB, Low Headroom	A	H4 + 173
NC, Low Headroom	A	H4 + 171
NB, Normal Headroom	A	H4 + 180
NC, Normal Headroom	A	H4 + 180

ND Hoists

Hoist	Case	ES mm
ND, Low Headroom	B	H1 + 31
ND, Normal Headroom, Reeving 02/04, Normal Track	B	H1 + 187
ND, Normal Headroom, Reeving 02/04, Curved Track	B	H1 + 137
ND, Normal Headroom, Reeving 06/08, Length Codes D/E	B	H1 + 128
ND, Normal Headroom, Reeving 06/08, Length Codes F/G	B	H1 + 88
ND, Normal Headroom, Reeving 22/24/26/28, Length Codes D/E/F	B	H1 + 131

ND hoist ES.dimensions given with maximum amount of counterweights.

D007500_A
157545

Note: All dimensions in mm.

Solo Electrics In External Cubicle, NB/NC/ND Low Headroom And Normal Headroom Hoists

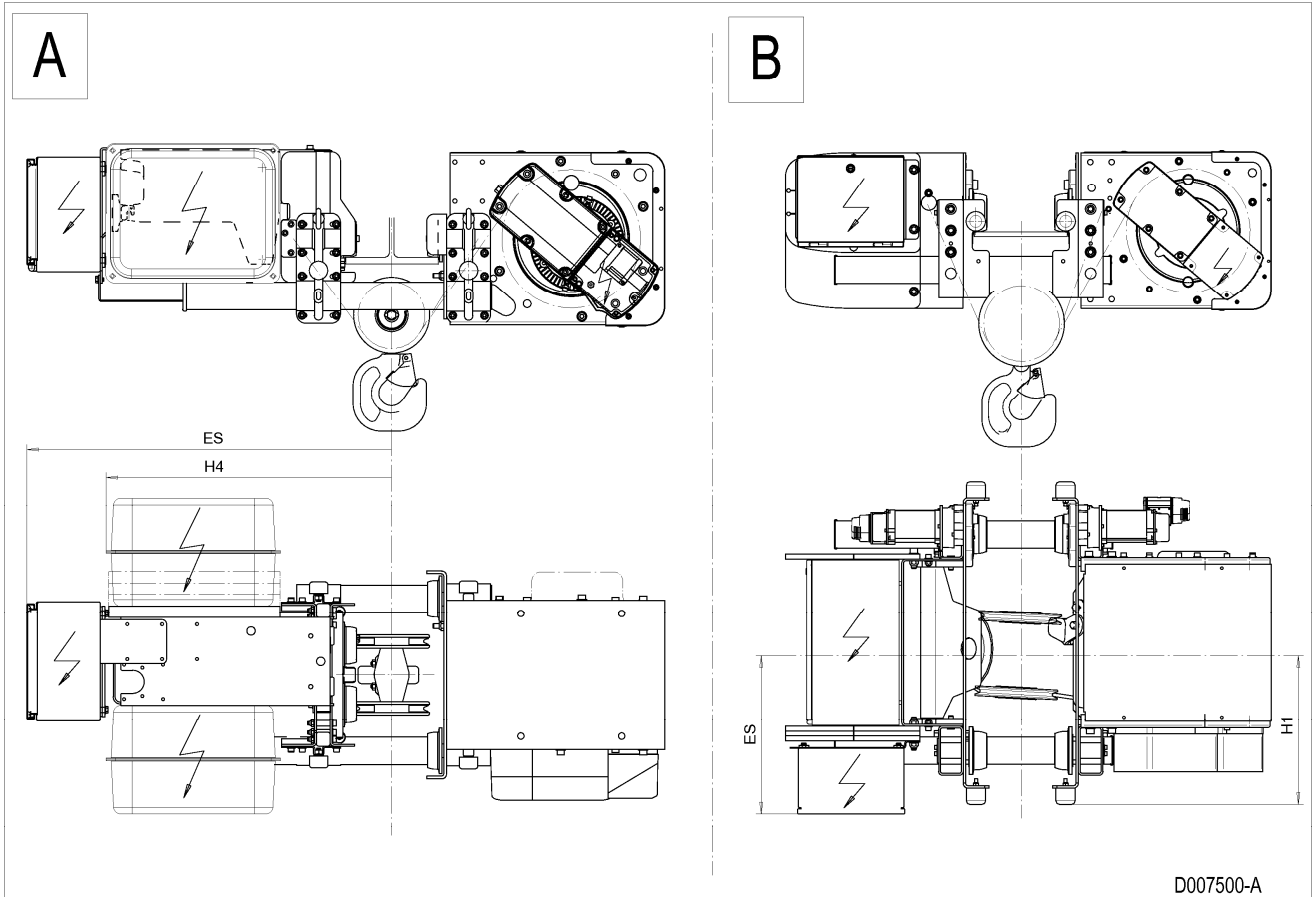

D007500-A

115 HOOK OPERATED ULTIMATE HOISTING LIMIT

The hook operated ultimate hoisting limit is adjusted to engage when the hook is in the minimum C-dimension attainable with a given hoist, as shown in the dimension tables in this technical guide.

The minimum C-dimension is limited by the surrounding steel structure and rope fleet angles. The primary hoisting limit switch must be set to engage before the ultimate limit engagement point. The actual C-dimension is thus increased by the difference between these engagement points.

Additionally, in some trolley constructions, the steel structure of the ultimate limit may restrict hook travel, further impacting the C-dimension. This is the case especially with low headroom trolleys, where available space is most constricted. The tables below show the C-dimension increase for each hoist type.

Double Girder Hoists

Hoist	Reeving	C Increase mm
NB	02	90
	04	140
NC	all	90
ND/NE/NF	all	50

Fixed Hoists

Hoist	C Increase mm
NB	205
NC	90
ND/NE/NF	50

Normal Headroom Hoists

Hoist	C Increase mm
NB/NC	120
ND/NE	50

Low Headroom Hoists

Hoist	Reeving	B min mm	B max mm	C Increase mm
NB	all	80	270	135
		271	320	105
		321	370	75
		371	410	50
NC	02	100	250	215
		251	300	185
		301	350	150
		351	400	120
		401	450	85
		451	490	60
	04	100	199	80
		200	249	110
		250	300	145
		301	350	115
		351	400	80
		401	450	50
		451	490	20
		A2	100	300
	301		350	140
	351		400	110
	401		450	75
	A4	451	490	45
		100	300	175
		301	350	140
351		400	110	
ND	all	401	450	75
		451	490	45
		100	610	100
		610	100	

157665

Note: All dimensions in mm.

116 DOUBLE GIRDER TROLLEY OPTIONAL FEATURES

Double girder trolley optional features are installed at the end of the hoist end carriages, thus increasing the hoist overall dimensions BU and RO. The following table shows how much the overall dimensions are increased for each end carriage type (discernable by the end carriage wheel diameter ØWD). The figures are those of how much an individual option affects the total length at one end of the end carriage.

Dimension Increase To Dimensions BU and RO By An Individual Option

ØWD mm	Anti-Jump Catch		Guide Roller		Rail Sweep		Proximity Sensor	
	BU mm	RO mm	BU mm	RO mm	BU mm	RO mm	BU mm	RO* mm
90	10	347	N/A	N/A	236	-	-	174
110	10	332	200	50	236	-	-	159
140	10	332	200	50	236	-	-	159
200	10	308	200	33	236	-	-	135
250	-	291	250	26	250	-	-	100
With 3 Wheels	-	247	250	-	250	-	-	56

*Maximum effect, when longer fixing plate is used and installation is done as indicated on the picture with letter 'A'.

Available buffer extensions lengths according to wheel diameter.

ØWD mm	Buffer Extension Length										
	100 mm	200 mm	250 mm	300 mm	400 mm	500 mm	600 mm	700 mm	750 mm	1000 mm	1500 mm
90	x	x		x	x	x	x	x			
110	x	x		x	x	x	x	x			
140	x	x		x	x	x	x	x			
200	x	x		x	x	x	x	x			
250	x		x			x			x	x	x
With 3 Wheels	x		x			x			x	x	x

Buffer extension length is added to dimension BU.

Buffer extensions never increase hoist overall dimensions in direction of dimension RO.

D007501_A
157729

Note: All dimensions in mm.

Note: Anti-Jump Catches are installed in pairs, one at each end of the end carriage.

Note: Guide rollers are always installed on the electric cubicle side, and they are adjustable for rails 80–120 mm wide. The end carriages are then equipped with flangeless wheels. Guide rollers are not available for the smallest end carriage.

Double Girder Trolley Optional Features

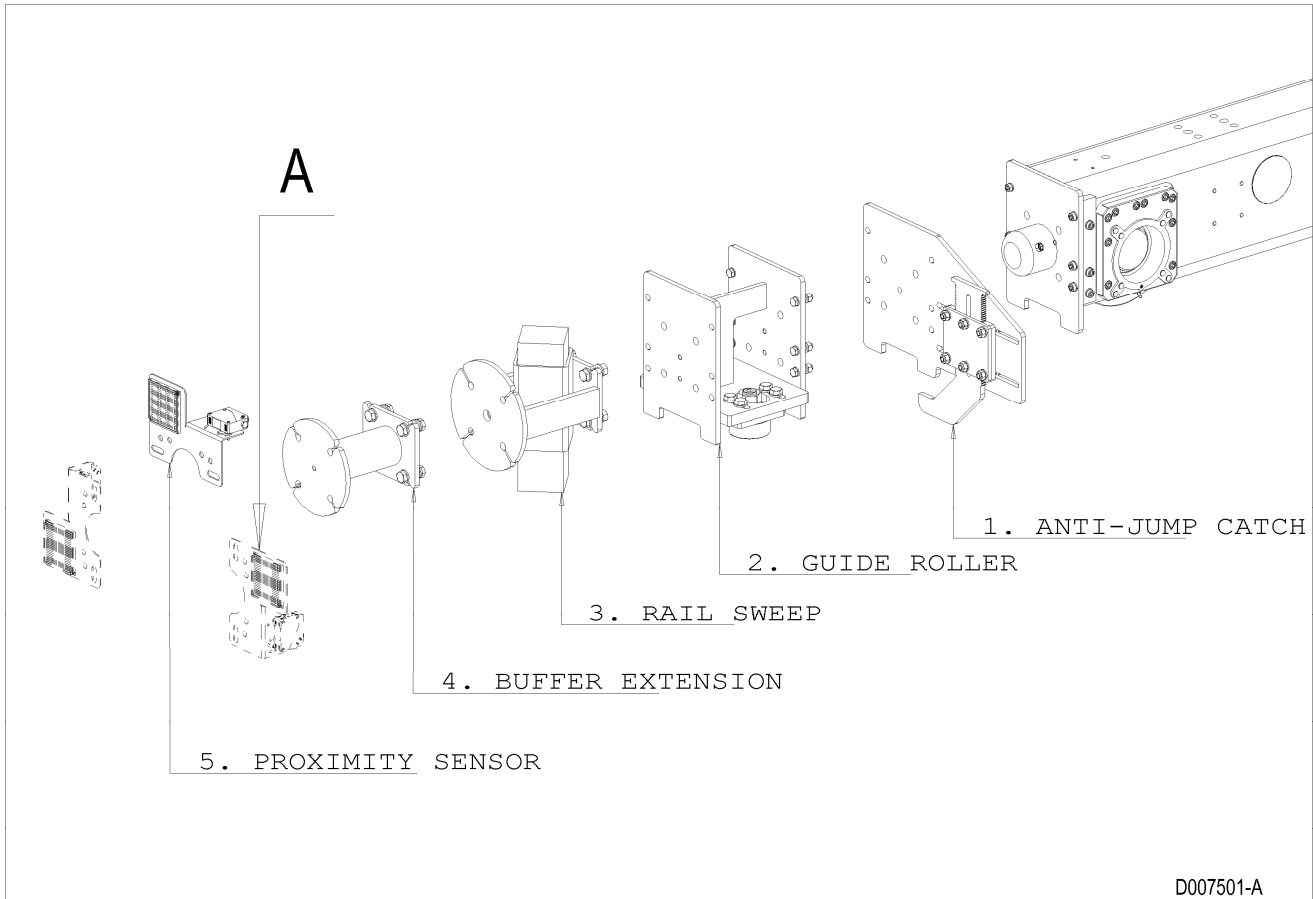

117 SERVICE PLATFORM: DOUBLE GIRDER TROLLEY, MEDIUM

Service Platform Dimensions

Buffer Extension Lengths*

Hoist	End Carriage	PL1	PL2	PL3	PH1	PH2	PW	Travelling Motor Side	Hoisting Unit Side
		mm	mm	mm	mm	mm	mm	mm	mm
NC	QNC09	2035	255	495	749	1168	244	300	500
ND	QNC11	2235	305	555	748	1168	244	300	600
ND	QNC14	2235	245	585	745	1168	244	300	600
ND	QNC20	2235	230	570	693	1168	244	300	600
NE	QNC14	2895	572	498	555	1168	244	600	500
NE	QNC20	2895	554	480	493	1168	244	600	500
NE	QNC25	2895	563	469	408	1168	244	750	500
NF	QNC20	2895	554	480	493	1168	244	600	500
NF	QNC25	2895	563	469	408	1168	244	750	500
NF	QNC25B	2895	399	553	373	1168	244	750	500

*Use buffer extensions when two hoists on track.

Service Platform Weights NC/ND

R	SP1	SP2	SP3
mm	One platform, hoisting unit side kg	Two platforms, one on each side kg	One platform, travelling motor side, ND only. kg
1400	230	319	230
1700	249	358	249
2000	268	396	268
2400	294	447	294

Service Platform Weights NE/NF*

R	SP1	SP2	SP3
mm	One platform, hoisting unit side kg	Two platforms, one on each side kg	One platform, travelling motor side kg
1400	243	358	249
1700	267	406	274
2000	290	455	299
2400	321	520	333
2700	345	568	358
3100	376	636	394
3400	399	683	418
3800	430	748	451
4200	462	812	485

* If the end carriage is QNC25B, reported weight increases by 20 kg.

D007355_A
135661

Note: All dimensions in mm.

Note: All service platforms are available for medium double girder trolleys ONLY.

Service Platform: Double Girder Trolley, Medium

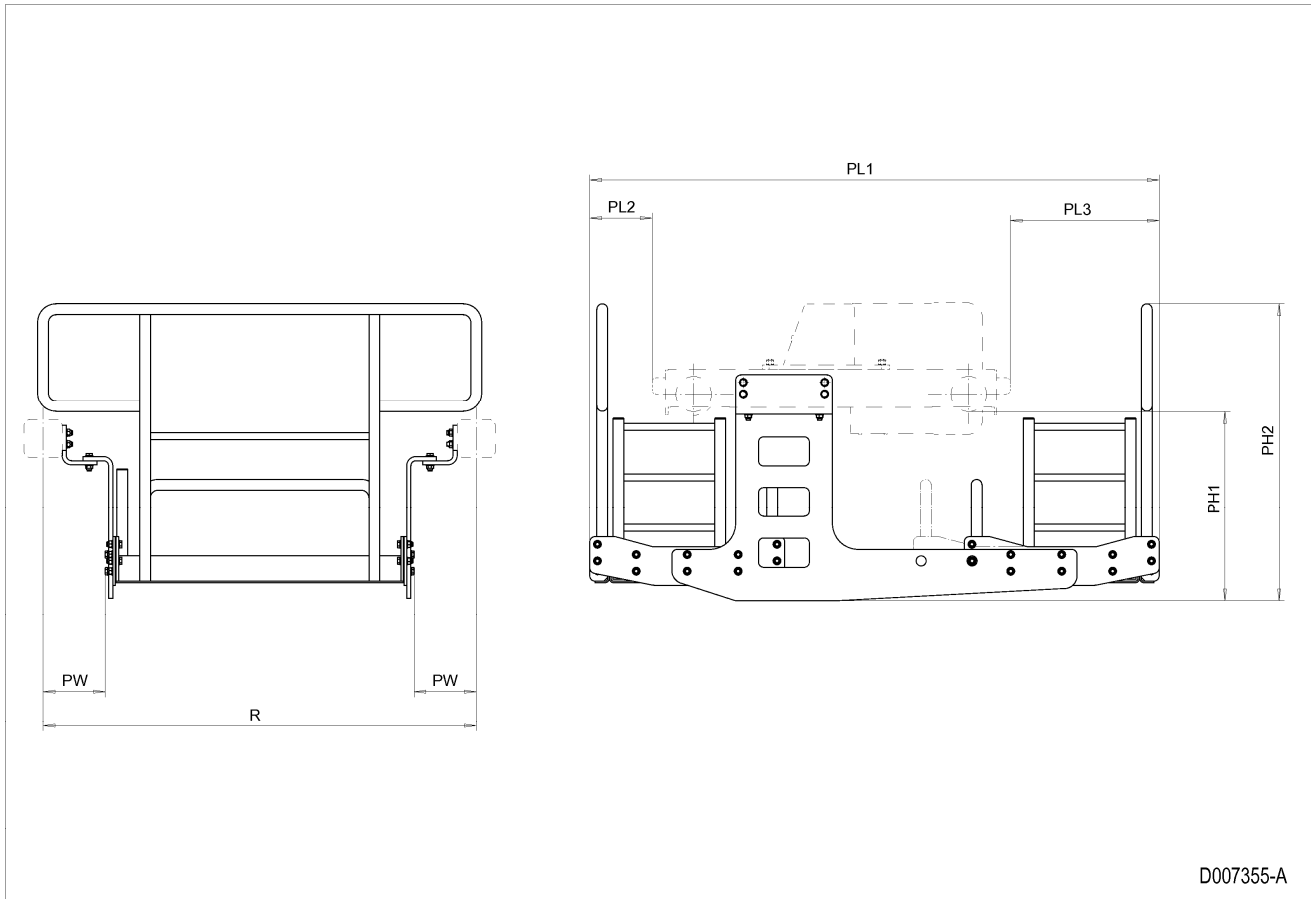

D007355-A

118 HOOK

118.1 Standard Hook Block Dimensions

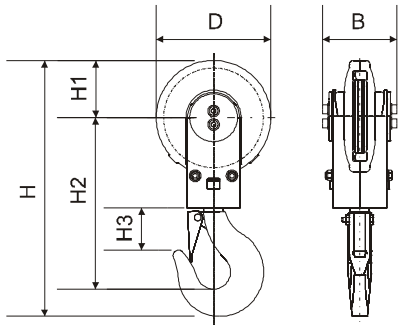

Figure 1

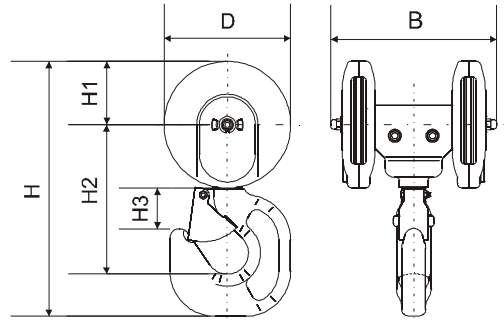

Figure 2

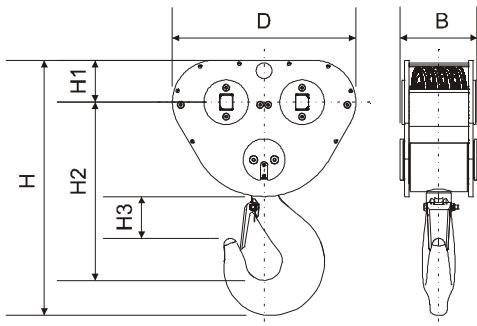

Figure 3

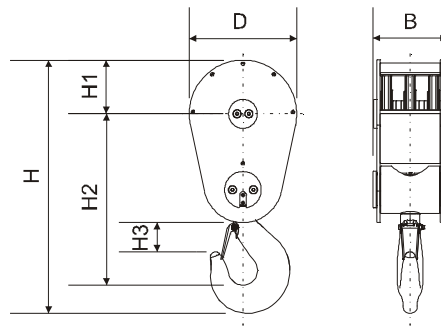

Figure 4

Standard Hook Block Dimensions

Hoist frame	Rope falls	Hoist duty			Hook forging	Fig.	Hook block dimensions (mm)						Weight (kg)
		1Am/M4	2m/M5	3m/M6			H	H1	H2	H3	D	B	
Z	02		M5		RSN 1 V	1	385	84	261	72	168	108	9.3
Z	04		M5		RSN 1.6 V	2	391	84	258	77	168	202	16.2
B	02		M5	M6	RSN 1 V	1	385	84	261	72	168	108	9.3
B	04		M5	M6	HBC 1.6 V	2	337	84	198	54	168	221	13
C	02	M4	M5	M6	RSN 1 V	1	425	102	282	72	204	118	14
C	04		M5	M6	HBC 2.5 V	2	426	102	259	92	204	270	22
C	04	M4			HBC 2.5 V	2	443	102	276	81	204	241	31.5
C	A2		M5	M6	RSN 1 V	1	385	84	261	72	168	108	9.3
C	A4		M5	M6	HBC 1.6 V	2	337	84	198	54	168	221	13
D	02	M4	M5	M6	HBC 2.5 V	1	578	142	371	92	283	148	31
D	04		M5	M6	HBC 5 V	2	548	142	316	90	283	376	46.5
D	04	M4			HBC 5 V	2	604	142	372	111	283	341	77.5
D	06		M5	M6	HBC 5 V	4	740	155	495	101	310	243	86
D	08	M4	M5		HBC 5 V	4	740	155	495	101	310	243	91
D	22		M5	M6	HBC 2.5 V	3	541	115	361	66	230	203	37
D	24		M5	M6	RSN 6 V	3	639	120	433	102	530	243	100
D	26		M5	M6	RSN 6 V	3	639	120	433	102	530	243	104
D	28	M4	M5		RSN 6 V	3	639	120	433	102	530	243	110
E	02	M4	M5	M6	HBC 5 V	4	830	205	535	101	410	244	98
E	04	M4	M5	M6	HBC 5 V	4	830	205	535	101	410	244	111
E	06	M4	M5	M6	RSN 10 T	4	966	205	654	112	410	282	181
E	08	M4	M5		RSN 16 T	4	1119	205	780	160	410	294	251
E	22	M4	M5	M6	HBC 5 V	4	740	155	495	101	310	243	78
E	24	M4	M5	M6	RSN 6 V	3	719	160	473	102	700	275	143
E	26	M4	M5	M6	RSN 10 T	3	830	160	564	117	700	282	192
E	28	M4	M5		RSN 16 T	3	974	160	680	160	700	294	277
F	22	M4	M5	M6	RSN 6 V	4	844	205	553	102	410	244	111
F	24	M4	M5	M6	RSN 16 T	3	1034	200	700	160	910	377	373
F	26	M4	M5	M6	RFN 20 T	3	1118	200	766	185	910	377	478
F	28	M4	M5		RFN 25 T	3	1219	200	847	205	910	377	603

118.2 Optional Lockable Hook Block Dimensions

Lockable hooks can be prevented from rotating. With the mechanism set to open position, the hook rotates freely. With the mechanism set to locked position, the hook is prevented from rotating. The locked hook has 4 possible orientations in 90 degree increments.

Lockable Hook Block Dimensions

Hoist Frame	Rope Falls	Hoist Duty			Hook Forging	Fig.	Hook Block Dimensions (mm)						C Dimension Change (mm)*	Weight (kg)
		1Am/M4	2m/M5	3m/M6			H	H1	H2	H3	D	B		
B	02		M5	M6	RSN 1 V	1	420	84	295	67	168	141	34	13
B	04		M5	M6	HBC 1.6 V	2	412	84	272	61	168	202	74	18
B	04		M5	M6	RSN 1.6 V	2	416	84	285	70	168	202	87	17
C	02	M4	M5	M6	RSN 1 V	1	454	102	312	67	204	117	30	15
C	02	M4	M5	M6	RSN 1.6 V	1	472	102	322	70	204	117	40	16
C	02	M4	M5	M6	HBC 1.6 V	1	467	102	309	61	204	117	27	17
C	04	M4	M5		HBC 2.5 V	2	476	102	309	76	204	240	50	33
C	04	M4	M5		RSN 4 V	2	505	102	336	88	204	240	77	34
D	02	M4	M5	M6	HBC 2.5 V	1	627	142	420	96	283	148	49	37
D	02	M4	M5	M6	RSN 2.5 V	1	613	142	413	82	283	148	42	36
D	04	M4	M5		RSN 6 V	2	657	142	429	107	283	340	113	79
D	06		M5	M6	RSN 6 V	4	780	155	539	128	310	243	44	91
D	08	M4	M5		RSN 6 V	4	780	155	539	128	310	243	44	96
D	22		M5	M6	RSN 4 V	4	593	115	411	101	230	203	50	39
D	24		M5	M6	RSN 6 V	3	665	120	459	128	530	243	26	96
D	26		M5	M6	RSN 6 V	3	665	120	459	128	530	243	26	101
D	28	M4	M5		RSN 6 V	3	665	120	459	128	530	243	26	106
E	02	M4	M5	M6	RSN 6 V	4	870	205	582	128	410	244	47	107
E	04	M4	M5	M6	RSN 6 V	4	870	205	579	128	410	244	44	120
E	06	M4	M5	M6	RSN 10 T	4	987	205	675	133	410	282	21	184
E	08	M4	M5		RSN 16 T	4	1142	205	803	183	410	294	23	275
E	22	M4	M5	M6	RSN 6 V	4	780	155	539	128	310	243	44	86
E	24	M4	M5	M6	RSN 6 V	3	745	160	499	128	700	275	26	150
E	26	M4	M5	M6	RSN 10 T	3	852	160	585	138	700	281	21	199
E	28	M4	M5		RSN 16 T	3	997	160	703	160	700	294	23	288
F	22	M4	M5	M6	RSN 6 V	4	870	205	579	128	410	243	26	119
F	24	M4	M5	M6	RSN 16 T	3	1050	200	716	176	910	376	16	377
F	26	M4	M5	M6	RFN 20 T	3	1153	200	801	220	910	377	35	477
F	28	M4	M5		RFN 25 T	3	1253	200	881	239	910	378	34	608

*The figure represents an increase to the hoist C dimension when equipped with lockable hook instead of a standard hook.

118.3 Optional Isolated Hook Block Dimensions

Isolated hooks are isolated against electrical current transmitted between the hook forging and the steel wire rope.

Isolated Hook Block Dimensions

Hoist Frame	Rope Falls	Hoist Duty			Hook Forging	Fig.	Hook Block Dimensions (mm)						C Dimension Change (mm)*	Weight (kg)
		1Am/M4	2m/M5	3m/M6			H	H1	H2	H3	D	B		
B	02		M5	M6	RSN 1 V	1	419	84	295	68	168	148	34	10
B	04		M5	M6	HBC 1.6 V	2	418	84	278	62	168	202	80	20
B	04		M5	M6	RSN 1.6 V	2	422	84	291	71	168	202	93	19
C	02	M4	M5	M6	RSN 1 V	1	454	102	312	68	204	122	30	14
C	02	M4	M5	M6	RSN 1.6 V	1	472	102	322	67	204	122	40	16
C	02	M4	M5	M6	HBC 1.6 V	1	467	102	309	58	204	122	27	16
C	04	M4	M5		HBC 2.5 V	2	480	102	313	88	204	240	54	34
C	04	M4	M5		RSN 4 V	2	510	102	340	100	204	240	81	35
D	02	M4	M5	M6	HBC 2.5 V	1	627	142	420	109	283	162	49	32
D	02	M4	M5	M6	RSN 2.5 V	1	613	142	413	95	283	162	42	31
D	04	M4	M5		RSN 6 V	2	661	142	433	131	283	340	117	79
D	06		M5	M6	RSN 6 V	4	757	155	516	105	310	243	21	86
D	08	M4	M5		RSN 6 V	4	757	155	516	105	310	243	21	91
D	22		M5	M6	RSN 4 V	4	580	115	402	92	230	203	41	37
D	24		M5	M6	RSN 6 V	3	642	120	436	105	530	243	3	94
D	26		M5	M6	RSN 6 V	3	642	120	436	105	530	243	3	99
D	28	M4	M5		RSN 6 V	3	642	120	436	105	530	243	3	104
E	02	M4	M5	M6	RSN 6 V	4	847	205	556	105	410	244	21	102
E	04	M4	M5	M6	RSN 6 V	4	847	205	556	105	410	243	21	112
E	06	M4	M5	M6	RSN10 T	4	976	205	664	107	410	282	10	169
E	08	M4	M5		RSN 16 T	4	1136	205	797	167	410	294	17	254
E	22	M4	M5	M6	RSN 6 V	4	757	155	516	105	310	243	21	82
E	24	M4	M5	M6	RSN 6 V	3	722	160	476	105	700	275	3	139
E	26	M4	M5	M6	RSN10 T	3	830	160	564	117	700	281	0	191
E	28	M4	M5		RSN 16 T	3	991	160	695	167	700	294	15	279
F	22	M4	M5	M6	RSN 6 V	4	846	205	556	105	410	243	3	112
F	24	M4	M5	M6	RSN 16 T	3	1056	200	722	167	910	377	22	381
F	26	M4	M5	M6	RFN 20 T	3	1138	200	786	198	910	377	20	480
F	28	M4	M5		RFN 25 T	3	1237	200	865	210	910	378	18	620

*The figure represents an increase to the hoist C dimension when equipped with isolated hook instead of a standard hook.

These special characteristics apply to all isolated hook blocks:

Special Characteristics For Isolated Hooks

Isolation Material	POM (Ertacetal H)
Ball Indentation Hardness	160 N/mm ² (ISO 2039-1)
Dielectric Strength	20 kV/mm
Comparative Tracking Index (CTI)	600 V
Nominal Voltage	1000 V
Test Voltage	3000 V/1min
Contamination Rate	3 (industry environment)
Material Class	1 (according to material CTI)
Minimum Clearance	0.8 mm (air) (up to 2000 m from sea-level)
Minimum Creepage Distance	12.5 mm (surface)

118.4 Single Hook Forging Dimensions

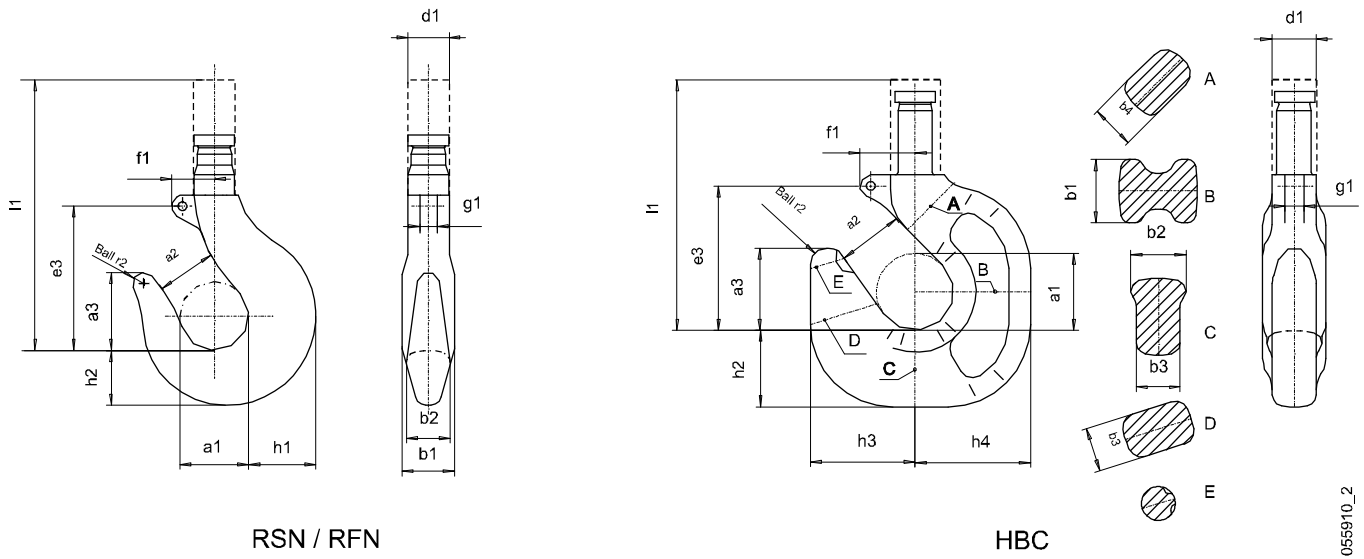

	RSN								RFN		HBC		
	RSN 1	RSN 1.6	RSN 2.5	RSN 4	RSN 5	RSN 6	RSN 10	RSN 16	RFN 20	RFN 25	HBC 1.6	HBC 2.5	HBC 5
a ₁	50 + 3	56 + 3	63 + 3	71 + 4	80 + 4	90 + 5	112 + 6	140 + 6	160 + 12	180 + 12	56 + 3	63 + 3	80 + 3
a ₂	40 + 3	45 + 3	50 + 3	56 + 4	63 + 4	71 + 5	90 + 6	112 + 6	125 + 12	140 + 12	45 + 3	51 + 3	63 + 3
a ₃	57 + 3	64 + 3	72 + 3	80 + 4	90 + 4	101 + 5	127 + 6	160 + 6	180 + 10	202 + 10	60 + 3	65 + 3	84 + 3
b ₁	38 + 3	45 + 3	53 + 3	63 + 4	71 + 4	80 + 5	100 + 6	125 + 6	140 + 16	160 + 16	46 + 3	52 + 3	75 + 3
b ₂	32 + 3	38 + 3	45 + 3	53 + 4	60 + 4	67 + 5	85 + 6	106 + 6	118 + 16	132 + 16	40 + 3	44 + 3	64 + 3
b ₃											32 + 3	37 + 3	59 + 3
b ₄											32 + 3	37 + 3	45 + 2
d ₁	30 + 3	36 + 3	42 + 3	48 + 4	53 + 4	60 + 5	75 + 6	95 + 6	106 + 12	118 + 12	38 + 3	44 + 3	55 + 3
e ₃	105 + 3	118 + 3	132 + 3	148 + 4	165 + 4	185 + 5	221 + 6	280 + 6	330 ± 10	360 ± 10	105 + 3	118 + 3	148 + 3
f ₁	31 + 1	35 + 1	40 + 1	45 + 2	51 + 2	57 + 2	46 + 3	58 + 3	68 + 5	74 + 5	40 + 1	45 + 2	56 + 2
g ₁	12.5 + 1	14 + 1	16 + 1	16 + 2	18 + 2	18 + 2	23 + 3	33 + 3	33 + 5	38 + 5	14 + 1	16 + 1	18 + 2
h ₁	48 + 3	56 + 3	67 + 3	80 + 4	90 + 4	100 + 5	125 + 6	160 + 6	180 + 20	200 + 20			
h ₂	40 + 3	48 + 3	58 + 3	67 + 4	75 + 4	85 + 5	106 + 6	132 + 6	150 + 20	170 + 20	56 + 3	65 + 3	90 + 4
h ₃											76 + 3	85 + 3	112 + 4
h ₄											84 + 3	100 + 3	130 + 4
l ₁	197 + 3	224 + 3	253 + 3	285 + 4	318 + 4	380 + 5	452 + 6	582 + 6	665 + 20	735 + 20	199 + 3	260 + 3	300 + 4
r ₂	50 + 3	56 + 3	63 + 3	71 + 4	90 + 4	90 + 5	112 + 6	140 + 6	28	32	56 + 3	63 + 3	80 + 4
weight (forging) kg	3.2	4.5	6.3	8.8	12.3	17.1	34	66	112	160	5.1	8	15

Note: Safety latch on HBC forging decreases dimension a₂ about 5 mm and about 15 mm on RSN/RFN forgings.
 Note: The '+ number' or '± number' after the nominal dimension indicates the tolerance. For example 160+6 means that the actual dimension is between 160 - 166 mm. 160±6 means that the actual dimension is between 154 - 166 mm

	Hook forging standard	
	RSN And RFN	HBC
Dimension standard	DIN 15401	DIN 15401 when applicable
Material standard	DIN 15400	DIN 15400

118.5 Ramshorn Hook Forging Dimensions

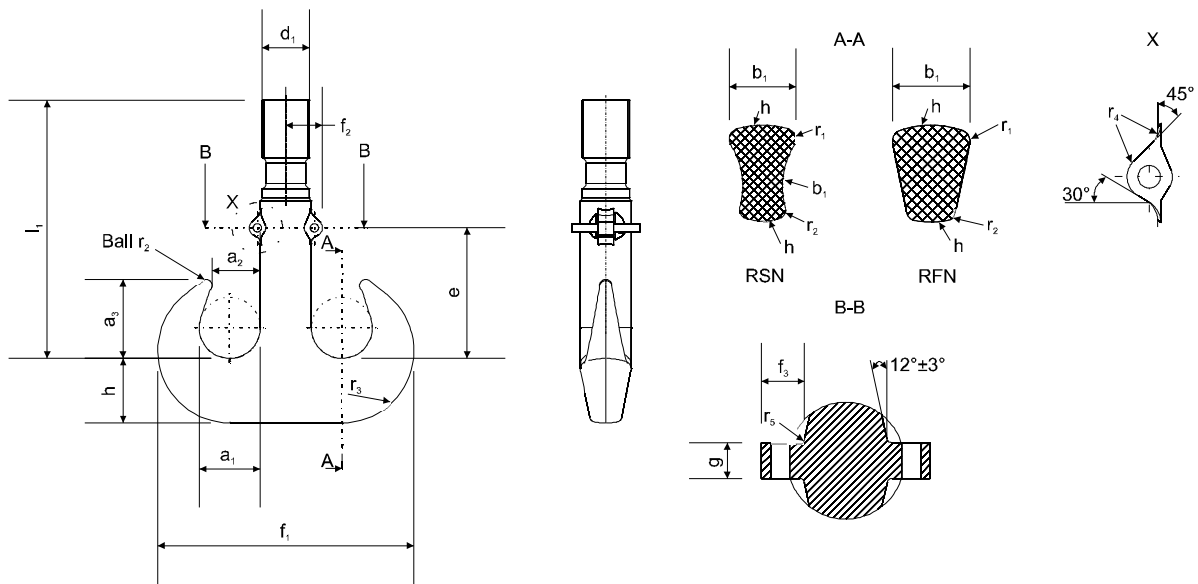

	RSN										RFN			
	1	1.6	2.5	4	5	6	10	16	20	25	10	16	20	25
a ₁	40 + 3	45 + 3	50 + 3	56 + 4	63 + 4	71 + 5	90 + 6	112 + 6	125 + 8	140 + 8	90 + 10	112 + 10	125 + 12	140 + 12
a ₂	32 + 3	36 + 3	40 + 3	45 + 4	50 + 4	56 + 5	71 + 6	90 + 6	100 + 8	112 + 8	71 + 10	90 + 10	100 + 12	112 + 12
a ₃	52 + 3	59 + 3	65 + 3	73 + 4	82 + 4	92 + 5	116 + 6	146 + 6	163 + 8	182 + 8	116 ± 8	146 ± 8	163 ± 10	182 ± 10
b ₁	28 + 3	34 + 3	40 + 3	48 + 4	53 + 4	60 + 5	75 + 6	95 + 6	106 + 8	118 + 8	75 + 12	95 + 12	106 + 16	118 + 16
d ₁	30 + 3	36 + 3	42 + 3	48 + 4	53 + 4	60 + 5	75 + 6	95 + 6	106 + 8	118 + 8	75 + 10	95 + 10	106 + 12	118 + 12
e	96 + 3	100 + 3	112 + 3	124 + 4	143 + 4	160 + 5	192 + 6	237 + 6	265 + 8	315 + 8	192 + 4	237 + 4	265 + 5	315 + 5
f ₁	158 + 3	183 + 3	208 + 3	238 + 4	266 + 4	301 + 5	377 + 6	471 + 6	531 + 8	598 + 8	377	471	531	598
f ₂	22 + 3	28 + 3	30 + 3	33 + 4	40 + 4	44 + 5	54 + 6	69 + 6	75 + 8	86 + 8	54 + 10	69 + 10	75 + 12	86 + 12
f ₃	14 + 1	14 + 1	14 + 1	23 + 2	23 + 2	23 + 2	27 + 4	36 + 4	36 + 5	45 + 5	27 + 4	36 + 4	36 + 5	45 + 5
g	12 + 1	12.5 + 1	14 + 1	16 + 2	16 + 2	18 + 2	23 + 4	28 + 4	33 + 5	33 + 5	23 + 4	28 + 4	33 + 5	33 + 5
h	36 + 3	43 + 3	50 + 3	60 + 4	67 + 4	75 + 5	95 + 6	118 + 6	132 + 8	150 + 8	95 + 16	118 + 16	132 + 20	150 + 20
l ₁	195 + 3	222 + 3	250 + 3	280 + 4	312 + 4	375 + 5	450 + 6	580 + 6	650 + 8	715 + 8	450 + 16	580 + 16	650 + 20	715 + 20
r ₁	4	5	6	7	8	9	11	14	16	18	11	14	16	18
r ₂	3.5 + 3	4 + 3	4.5 + 3	5.5 + 4	6.5 + 4	7 + 5	9 + 6	11 + 6	12.5 + 8	14 + 8	9	11	12.5	14
r ₃	44	51	58	87	75	85	106	132	150	170	106	132	150	170
r ₄	7	7	7	10	10	10	12	16	16	20	12	16	16	20
r ₅	1.6	1.6	1.6	2.5	2.5	2.5	3	4	4	5	3	4	4	5
weight (forging) kg	3.8	5.3	6.9	9.7	13.4	16.8	35.5	69.7	97.5	135	36.3	71.1	99.5	138

Note: Safety latch decreases dimension a₂ about 15 mm on RSN/RFN forgings.

Note: The '+ number' or '± number' after the nominal dimension indicates the tolerance. For example 160+6 means that the actual dimension is between 160 - 166 mm. 160±6 means that the actual dimension is between 154 - 166 mm

	Hook forging standard
	RSN And RFN
Dimension standard	DIN 15402
Material standard	DIN 15400

119 DRUM AND ROPE SHEAVE DIAMETERS

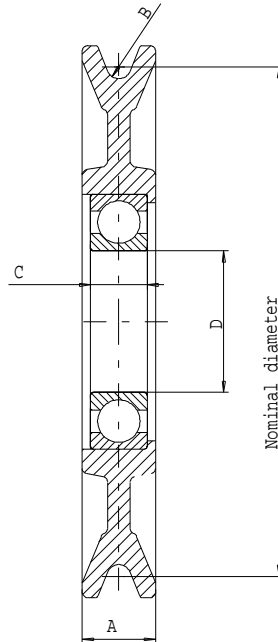

Rope sheave diameters	Rope diameter	Duty class	A	B	C	D
(nominal, mm)	(nominal, mm)	FEM / ISO	(mm)	(mm)	(mm)	(mm)
146	6.4	3m / ISO M6	22	3.3	18	40
180	8	3m / ISO M6	26	4.2	20	50
248	11	3m / ISO M6	38	5.8	23	65
338	15	3m / ISO M6	46	8	28	85

Frame size code	Rope diameter (mm)	Reeving	Rope drum diameter (nominal, (mm))	Rope drum pitch (mm)	Rope sheave diameter (nominal, (mm))	Number of rope clamps on drum
Z	6.2	Standard	243	7	146	2
B	6.4	Standard	303	7.2	146	3
C	8	Standard	355	9.1	180	3
D	11	Standard	406	12.5	248	4
D	8	True vertical	406	9.1	180	2x3
E	15	Standard	608	17.1	338	6
E	11	True vertical	608	12.5	248	2x4
F	15	True vertical	608	17.1	338	2x6

102134